



21061





LEGO.com/sustainable-packaging



FR
**DONNEZ
OU
RECYCLEZ**



ASSOCIATION

OU



MAGASIN

OU



DÉCHÈTERIE

Adresses sur quefairedemesdechets.fr



BUILDER



Apple and the Apple logo are trademarks of Apple Inc., registered in the U.S. and other countries and regions. App Store is a service mark of Apple Inc. Google Play and the Google Play logo are trademarks of Google LLC. Tencent and the Tencent logo are trademarks of Tencent Inc.

LEGO.com/devicecheck



LEGO® Builder



NOTRE-DAME DE PARIS

« Comment imaginer Paris sans la majestueuse cathédrale Notre-Dame ? Au fil des siècles, ce monument spectaculaire a résisté aux éléments, à la Révolution et à la destruction dévastatrice. Aujourd'hui encore, il reste l'une des attractions touristiques les plus appréciées de Paris. Lorsqu'on l'admire dans toute sa splendeur qui semble défier la gravité, on ne peut s'empêcher de se demander comment des architectes, des maçons et des bâtisseurs ont pu créer un tel monument dont la construction, commencée il y a près de 900 ans, s'est étendue sur plusieurs siècles. Inspirés et fascinés par les techniques ingénieuses employées par ces artisans, nous avons décidé de recréer cette magnifique cathédrale et ses détails délicats sous la forme d'un modèle LEGO®. »

« Ces instructions vous guideront tout au long du processus de construction. Chaque brique est minutieusement positionnée pour recréer un élément architectural spécifique de Notre-Dame de Paris. Chaque sachet contient les briques nécessaires pour restituer une période spécifique de la construction de la cathédrale, de 1163 à nos jours. »

Rok Žgalin Kobe, Senior LEGO® Designer

1163-1182

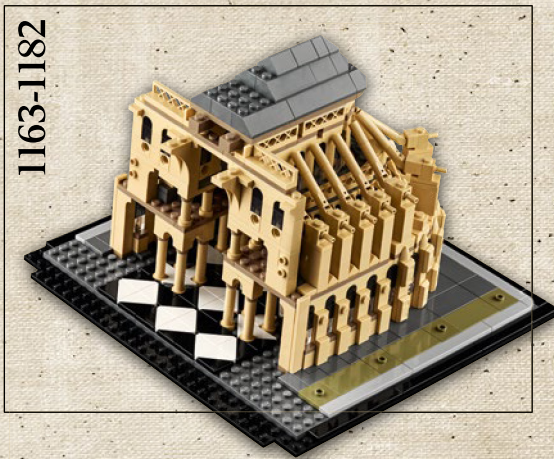

1163-1182 : La partie orientale de la cathédrale a été achevée en premier et a servi d'église provisoire pendant la construction du reste de la cathédrale.

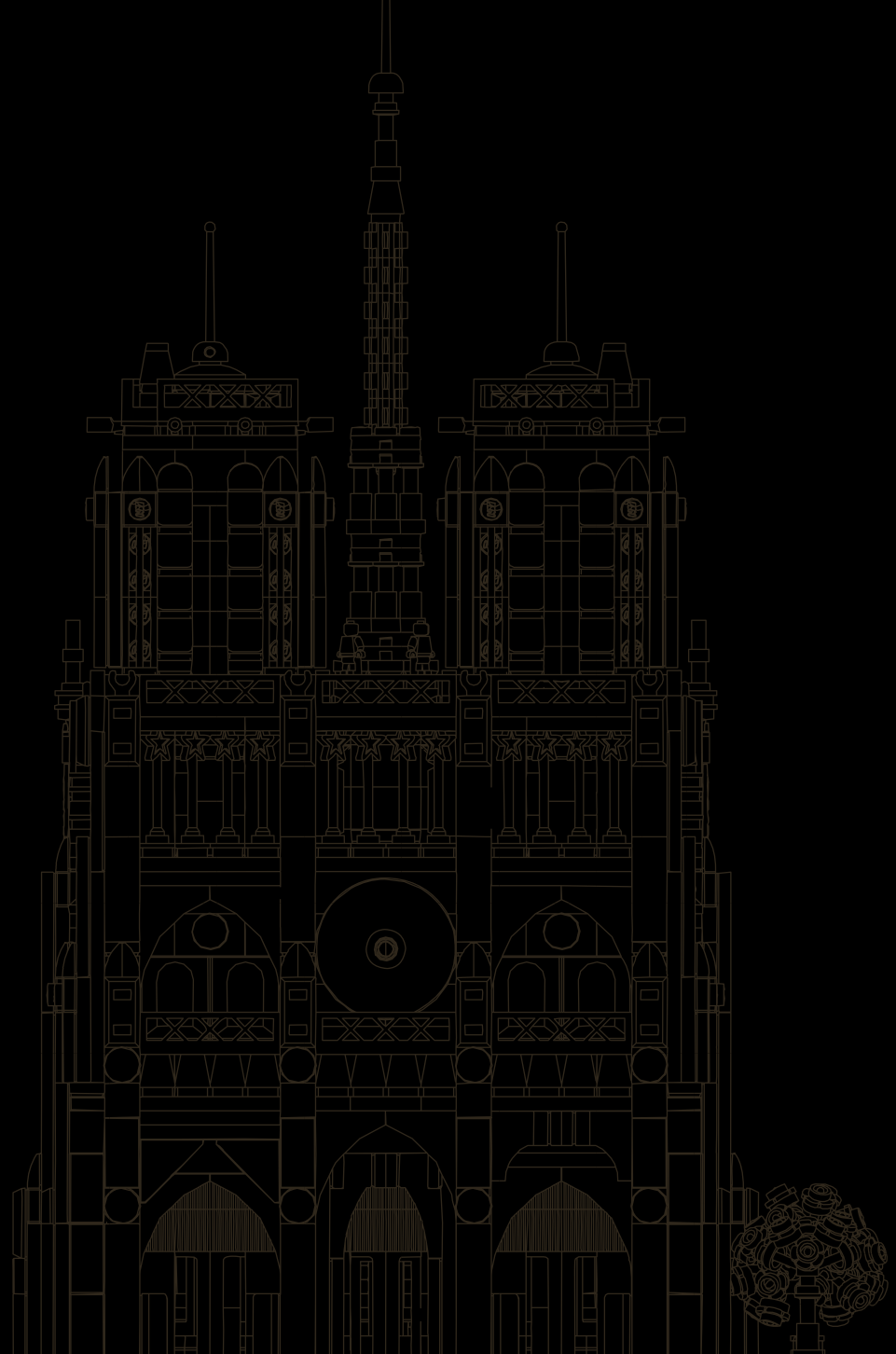

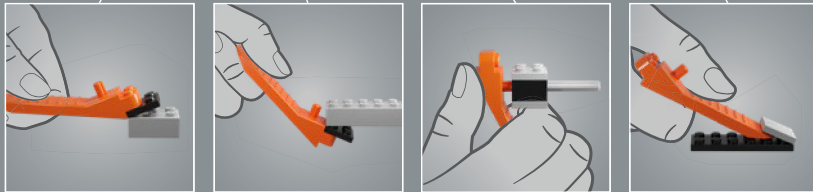
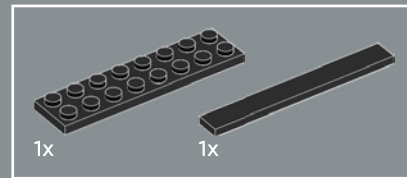
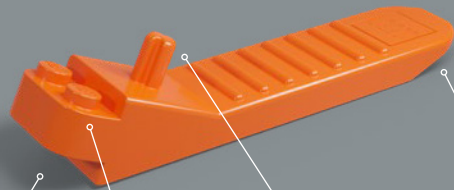

1

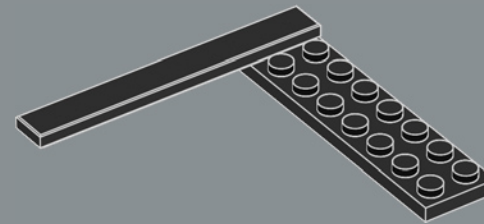

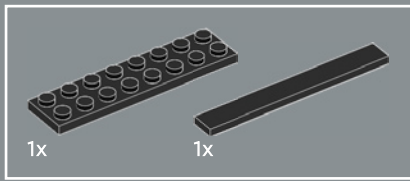

2

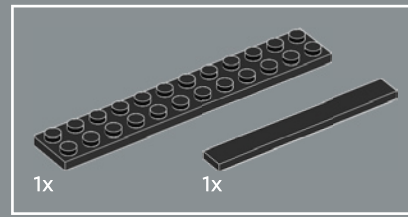
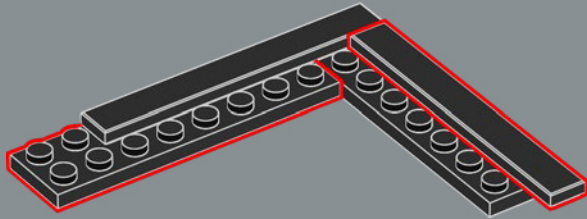

3

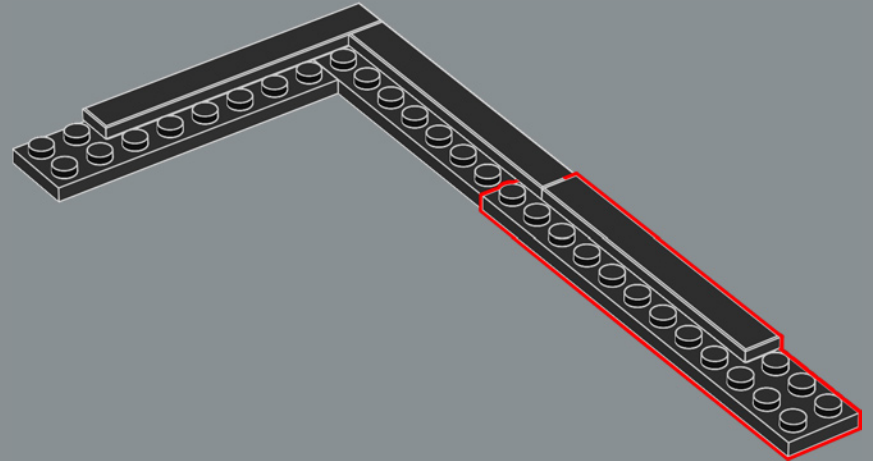

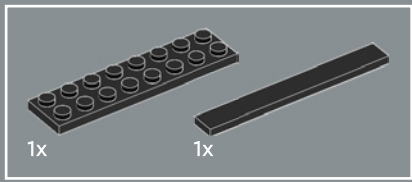

4

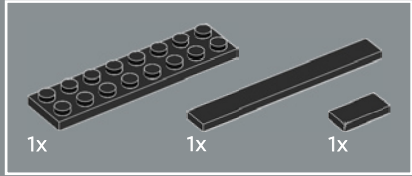
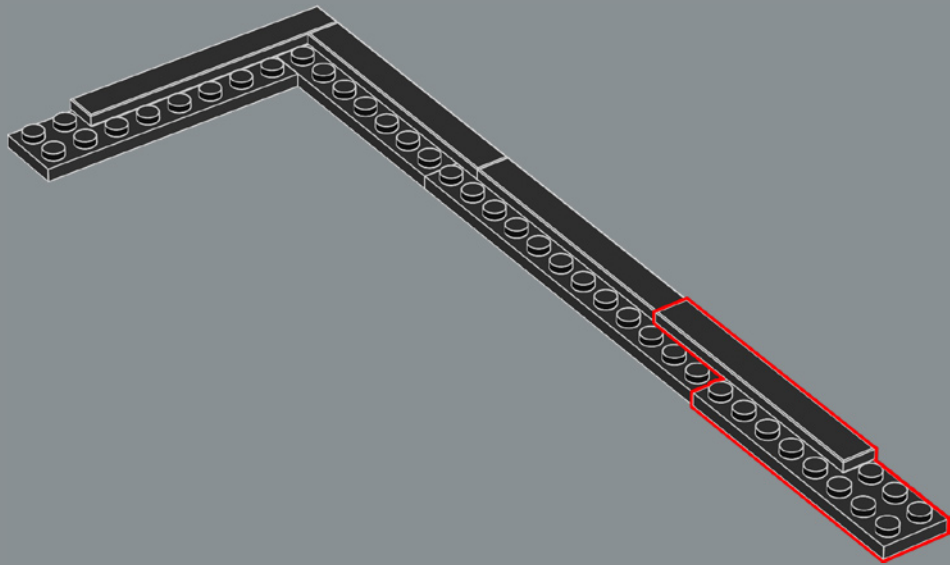

5

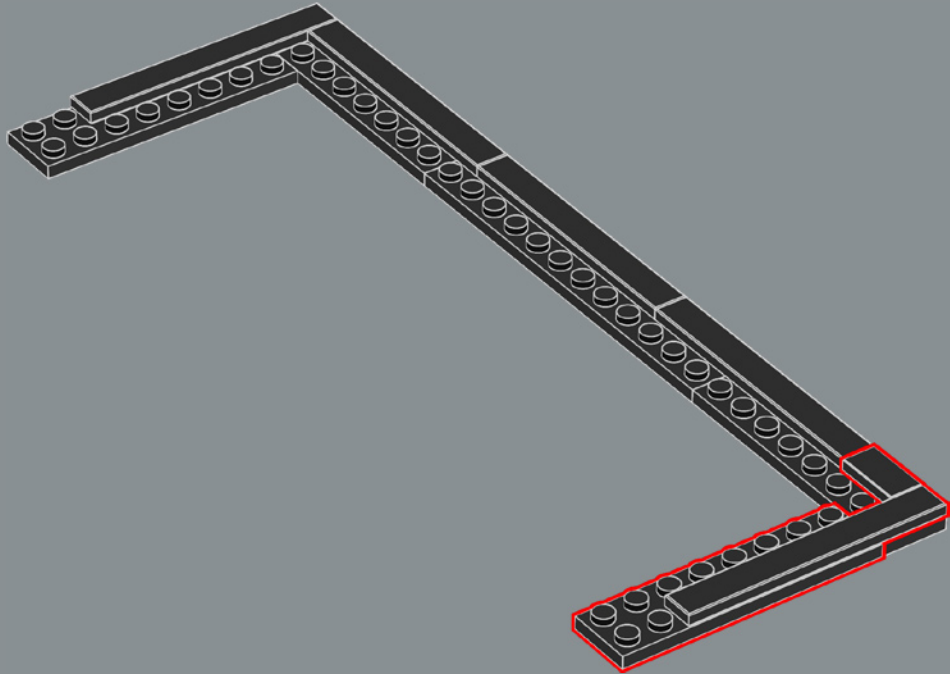

8

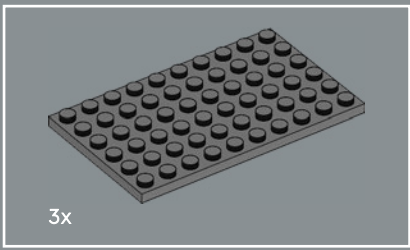

6

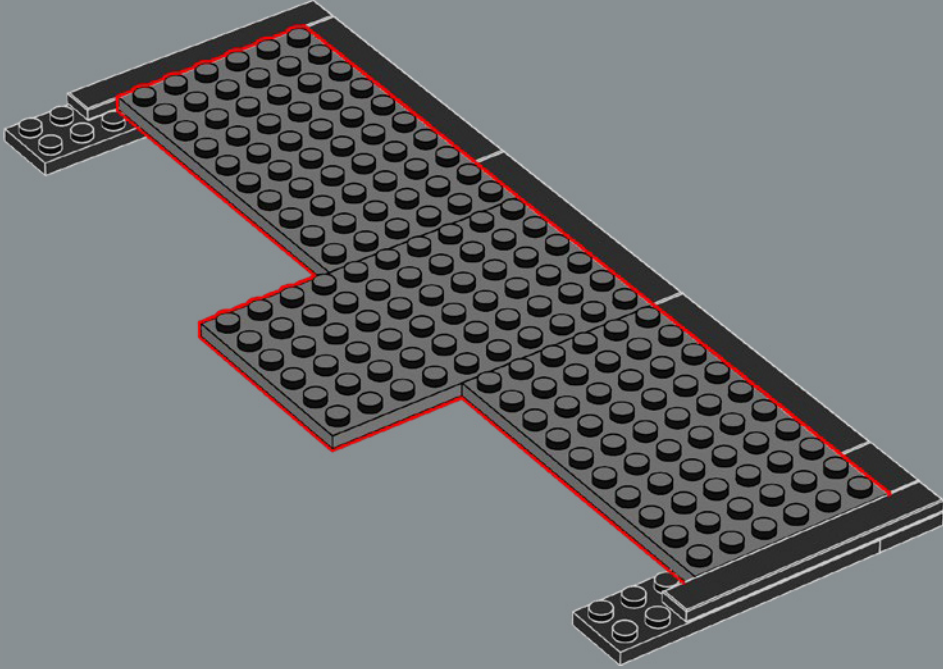

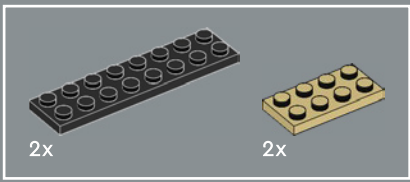

7

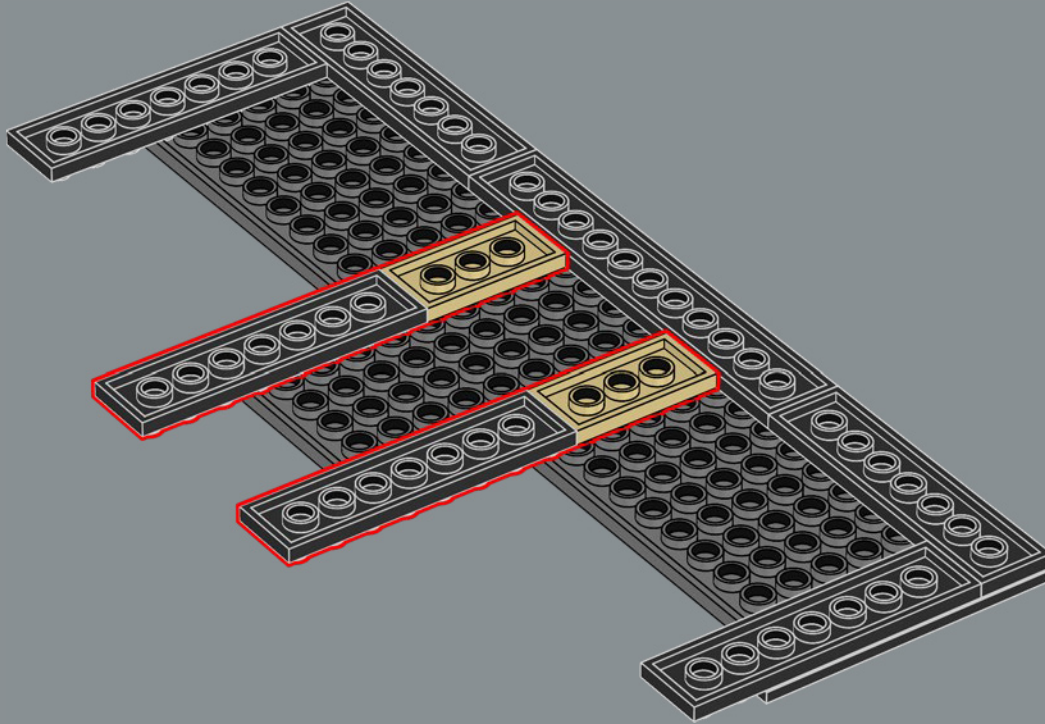

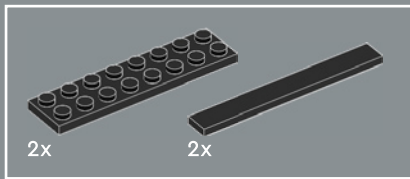

8

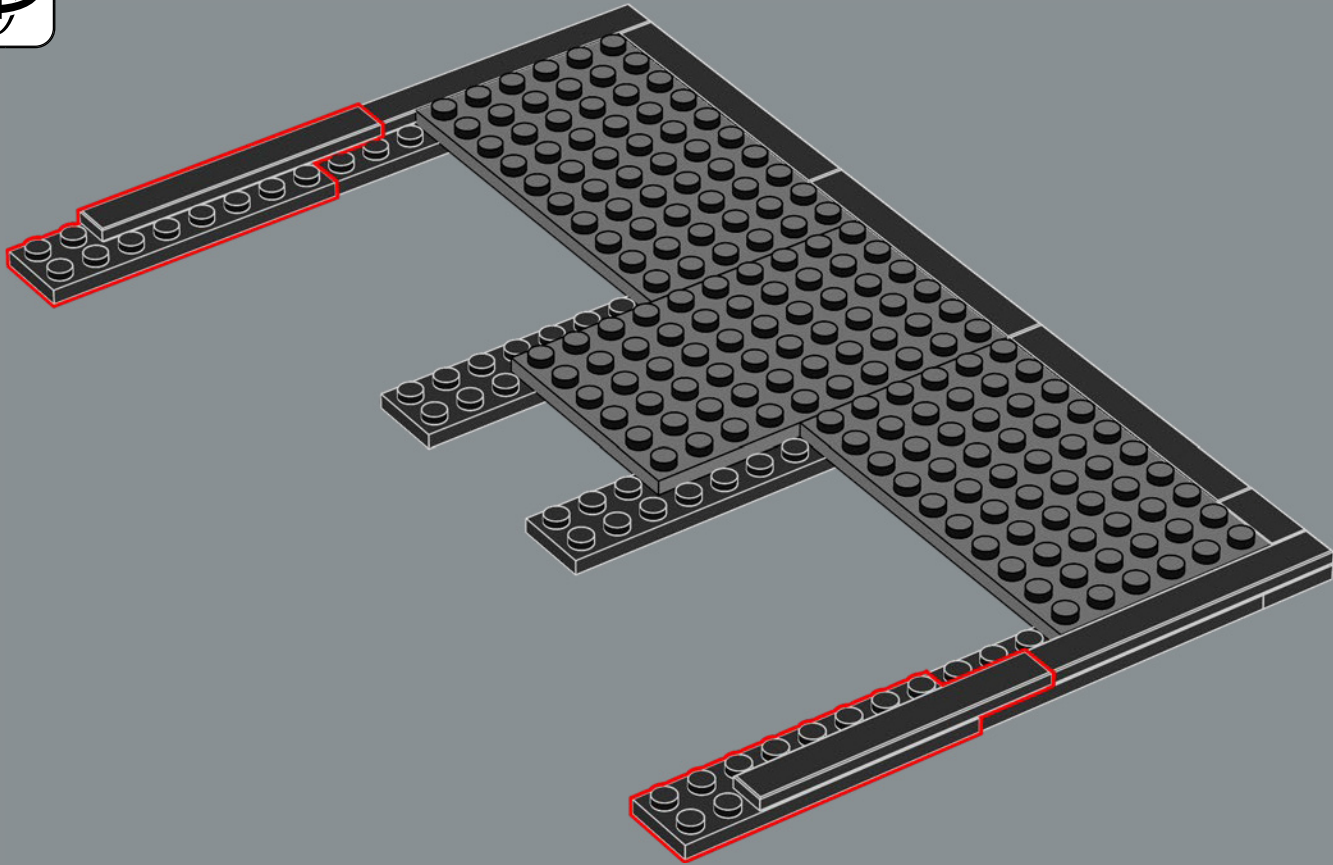

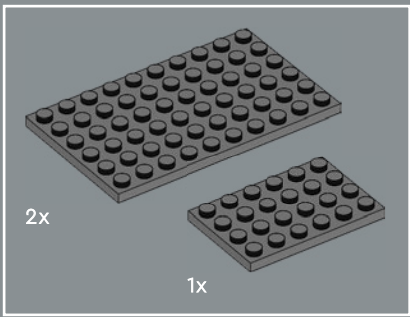

9

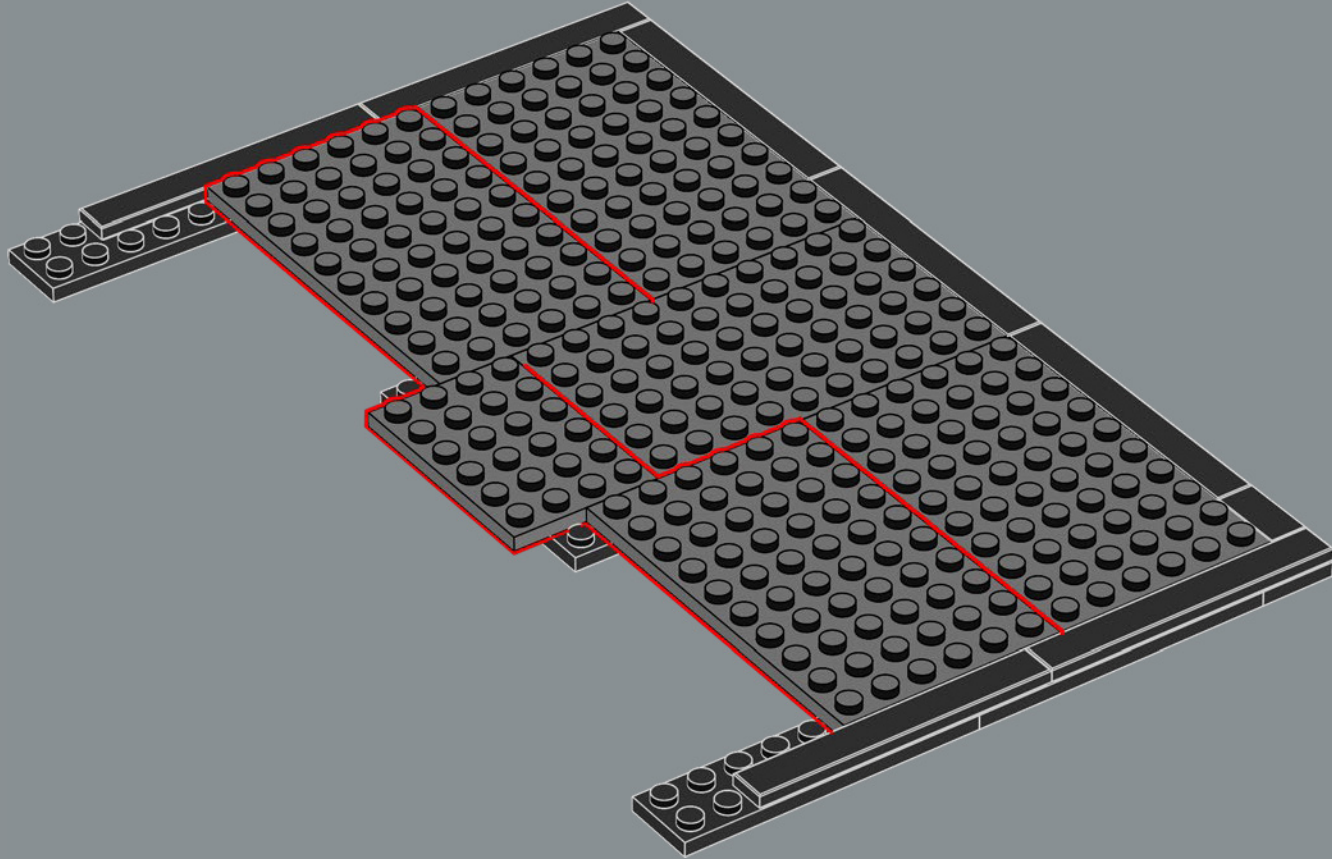

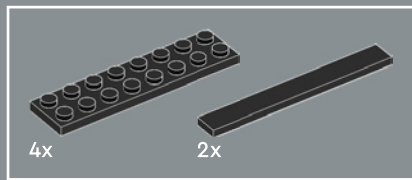

10

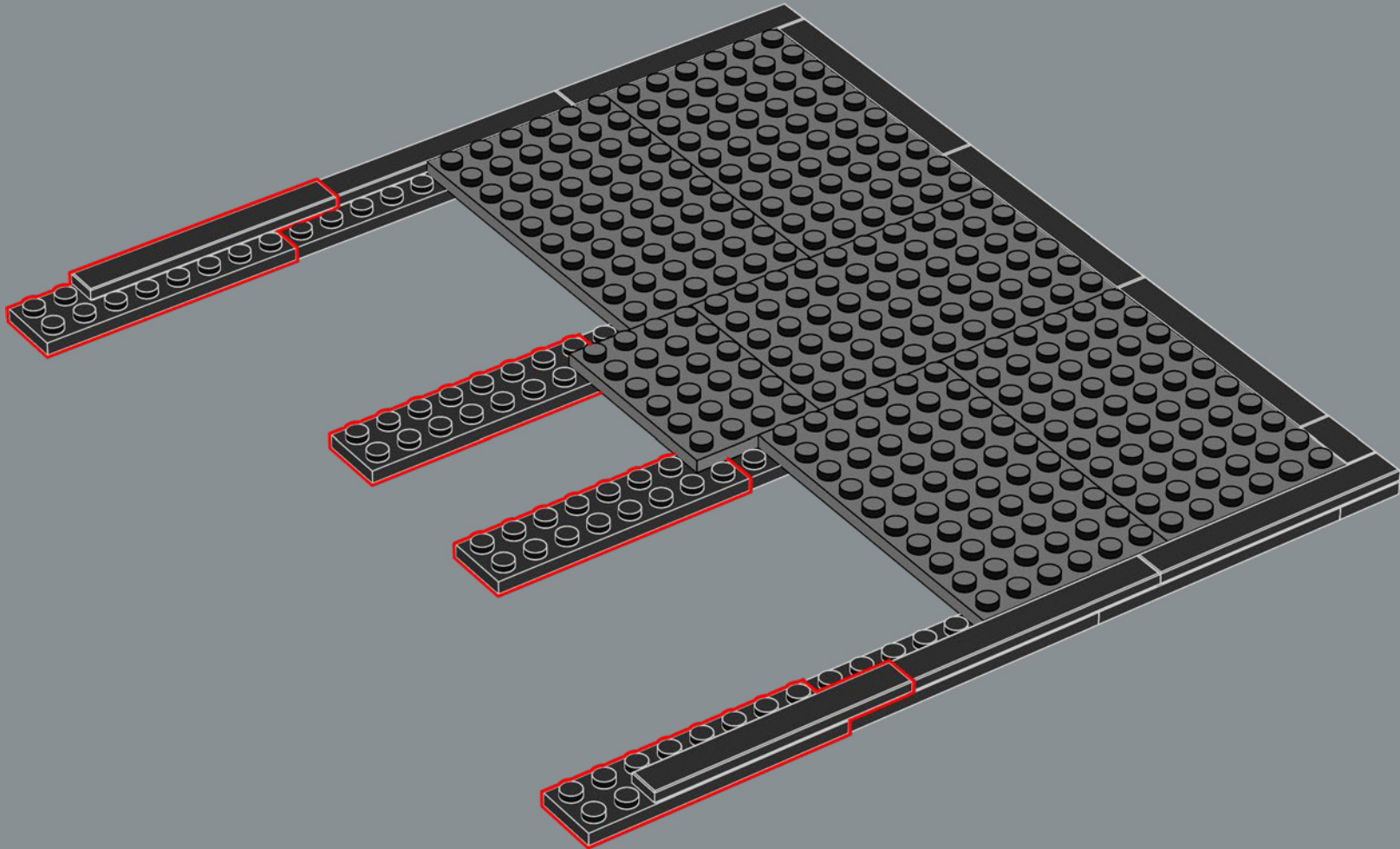

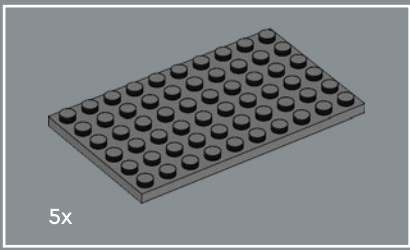

11

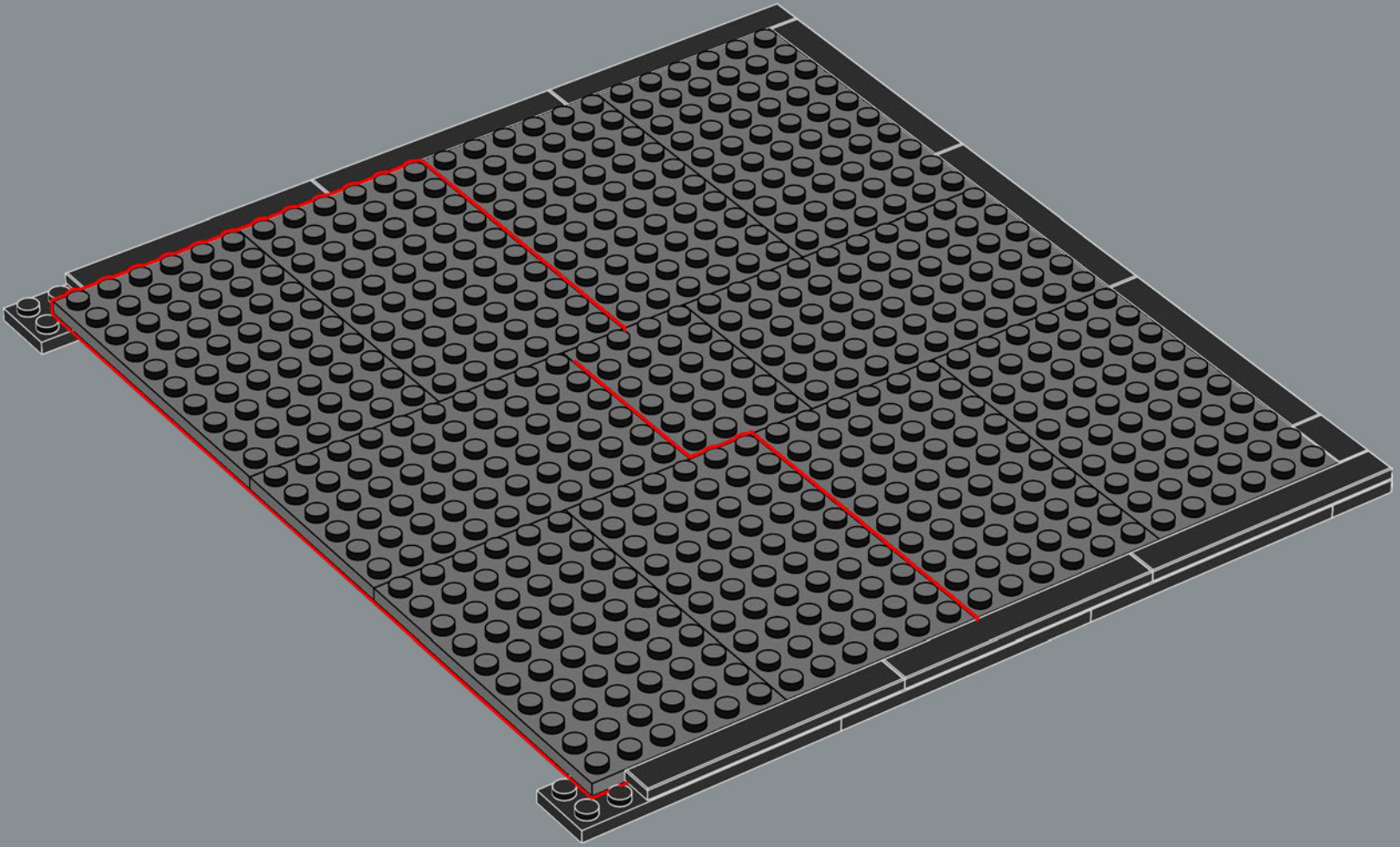

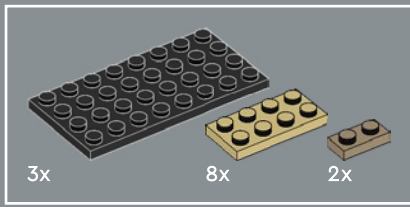

12

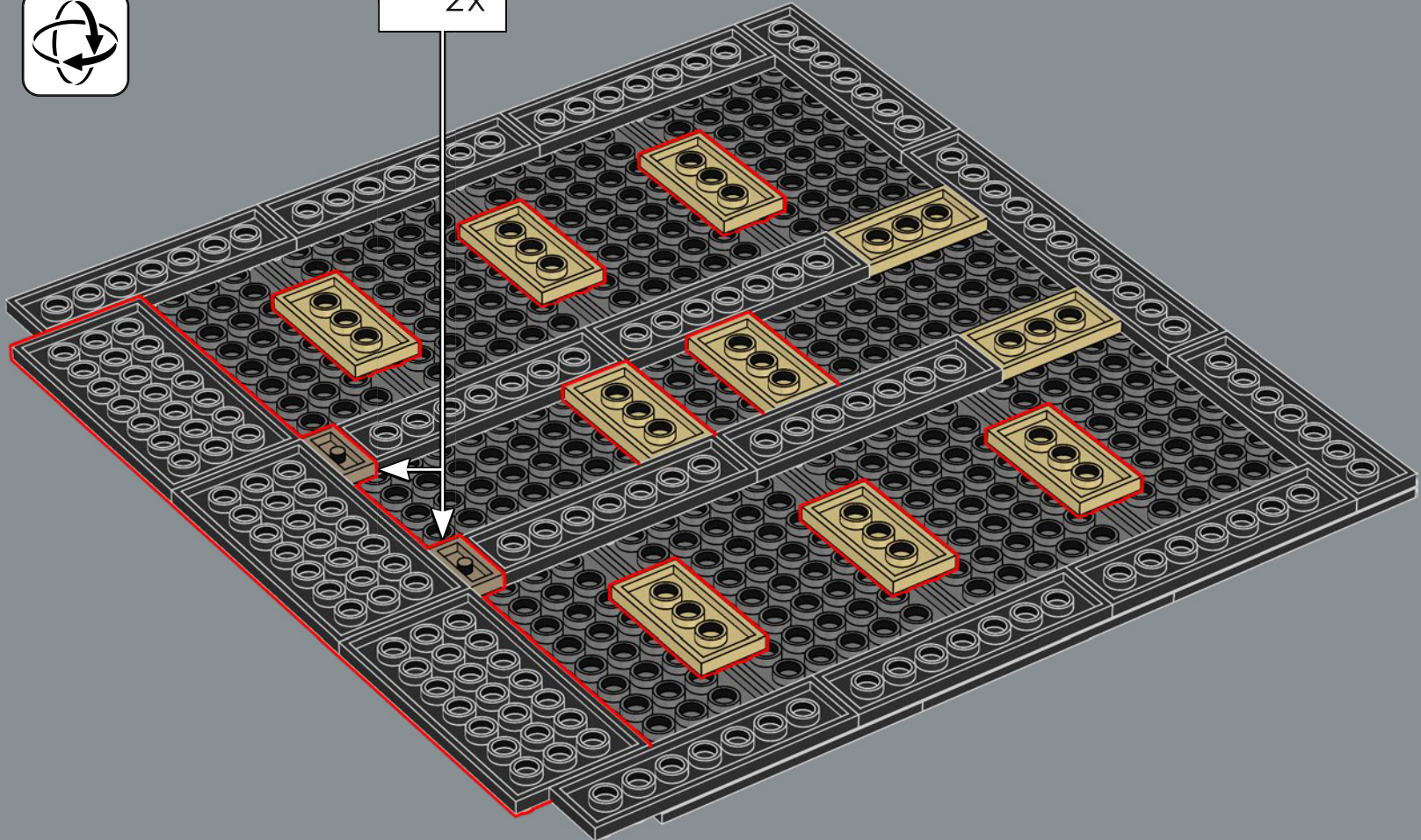
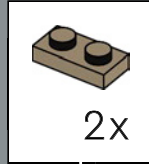

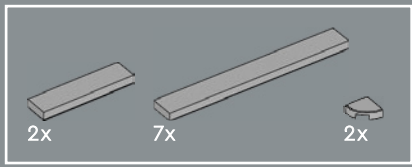

13

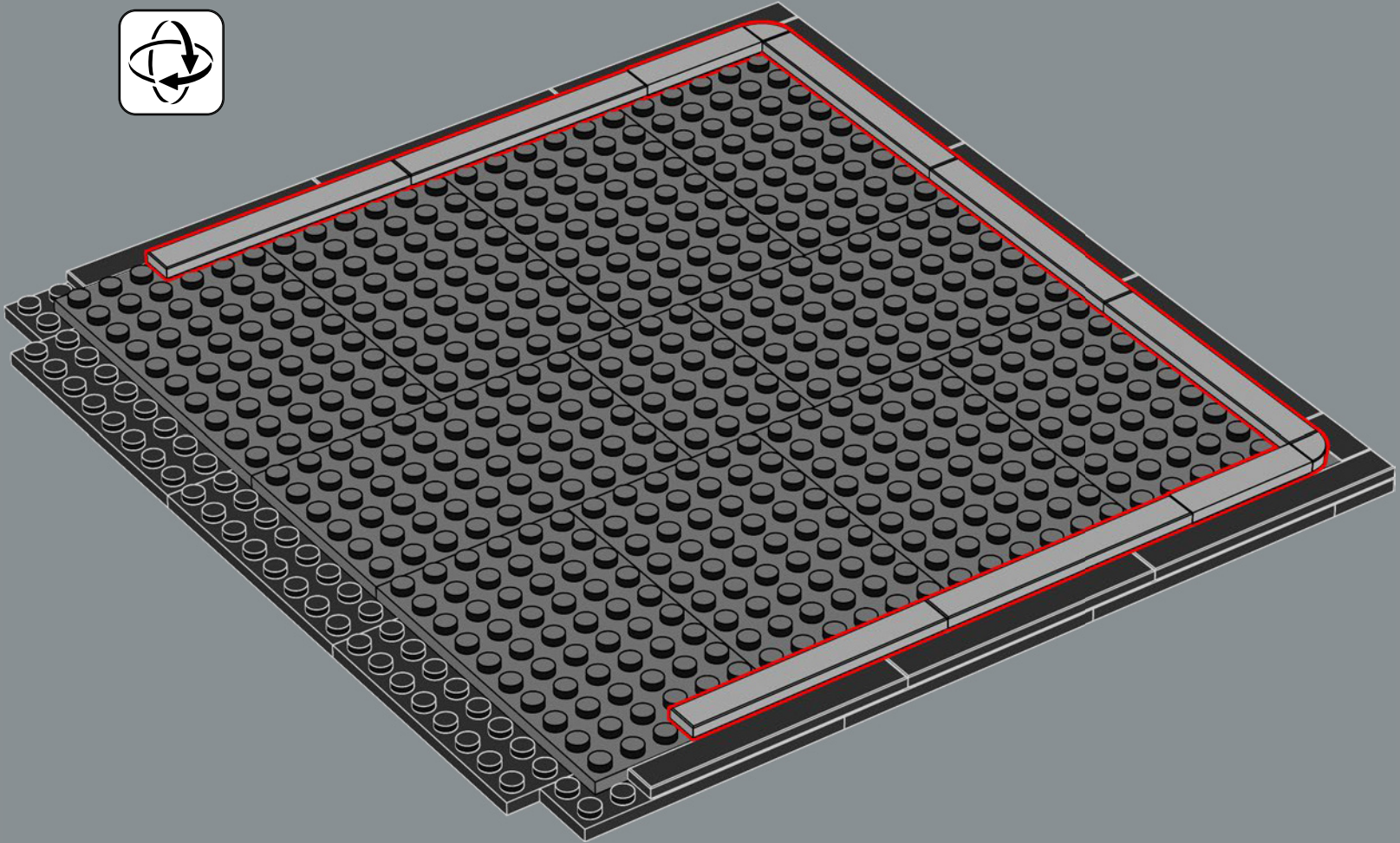

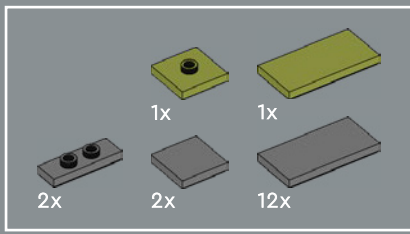

14

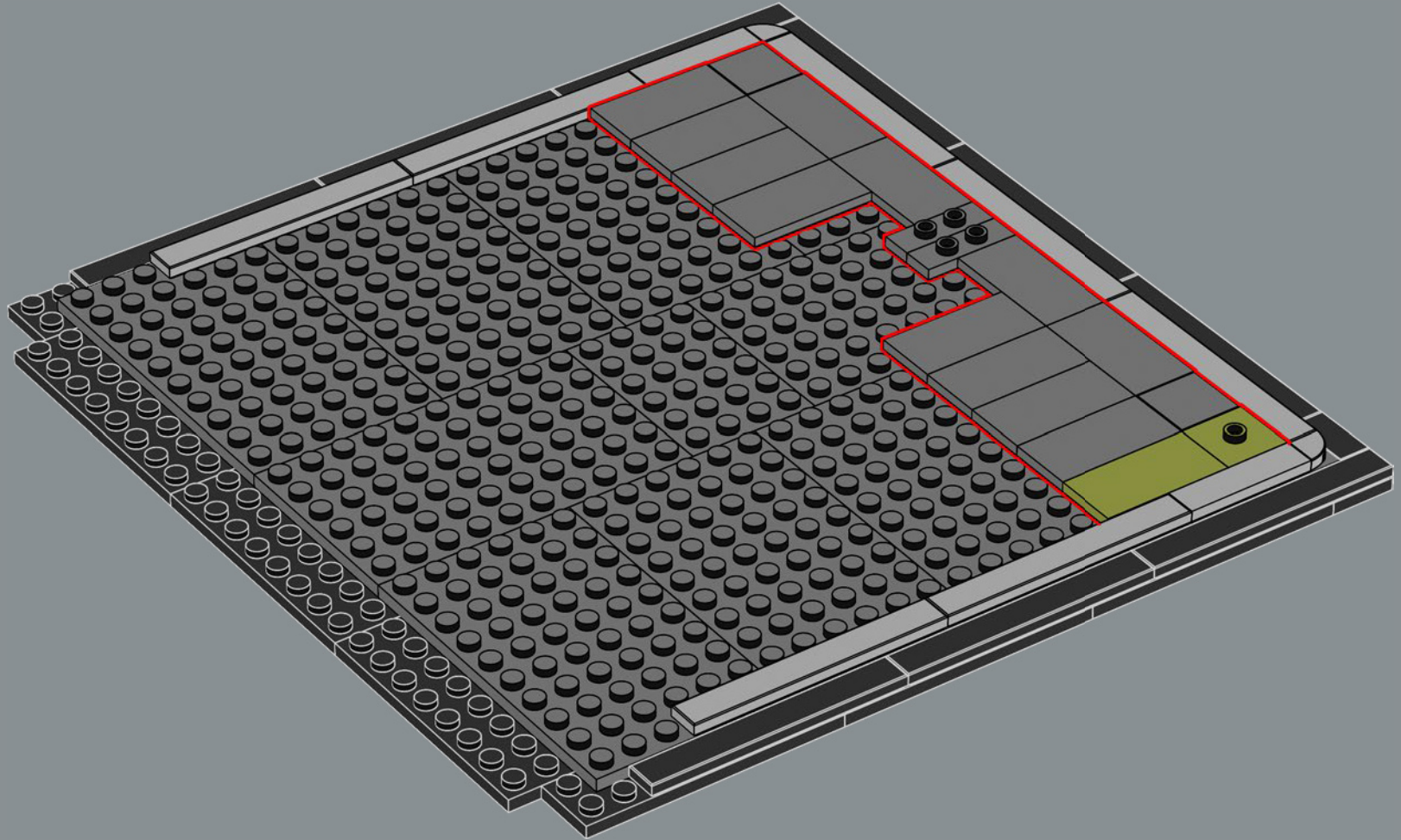

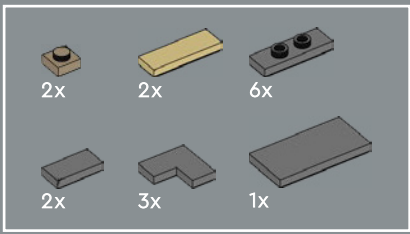

1163 - Les plans de la cathédrale Notre-Dame sont prêts. La construction commence et le Pape Alexandre III assiste à la pose de la première pierre.

15

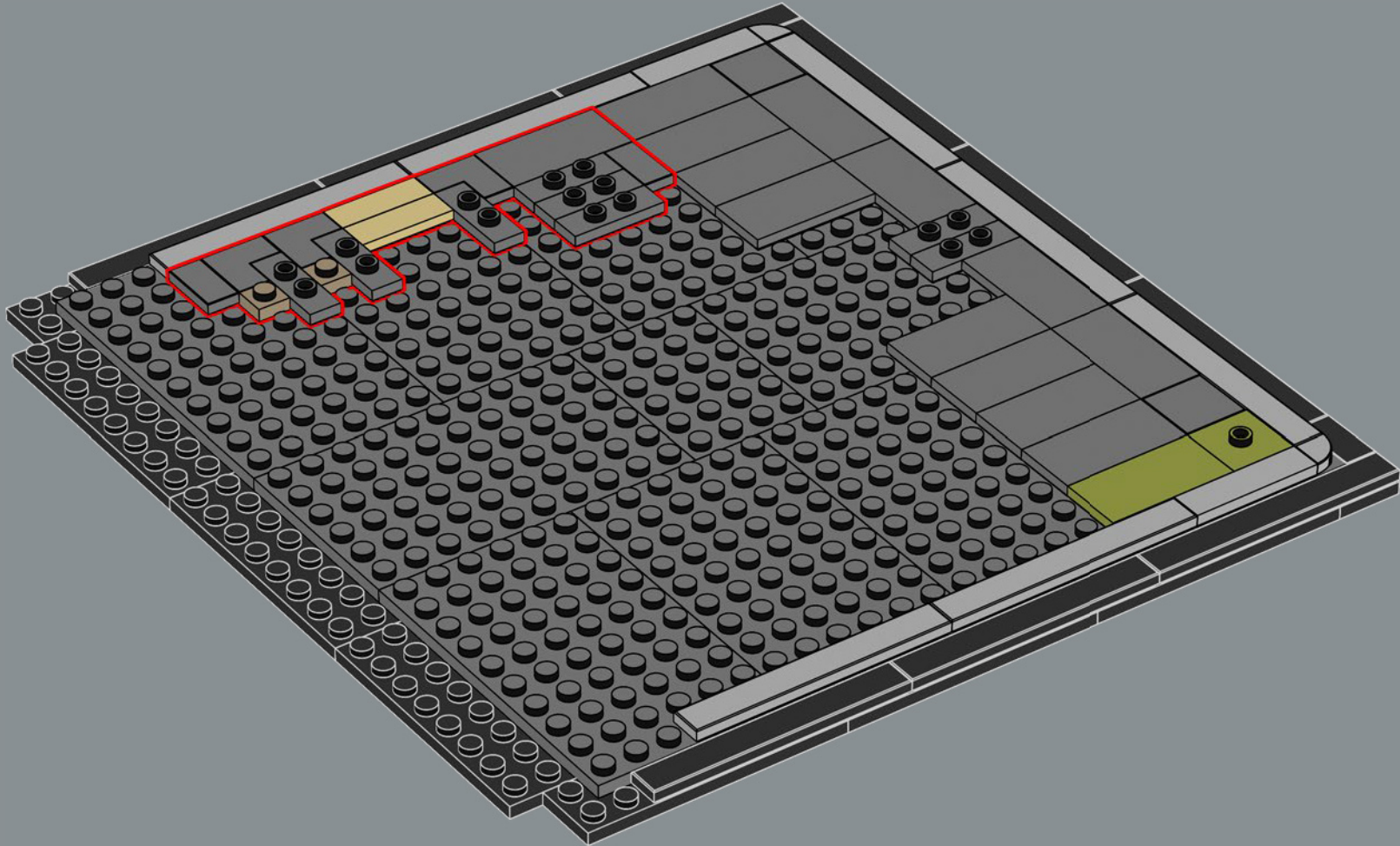

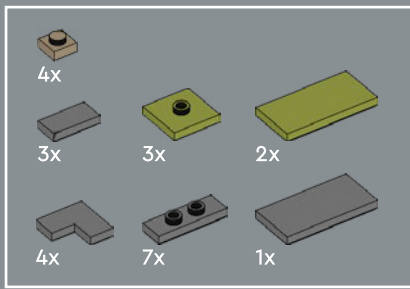

16

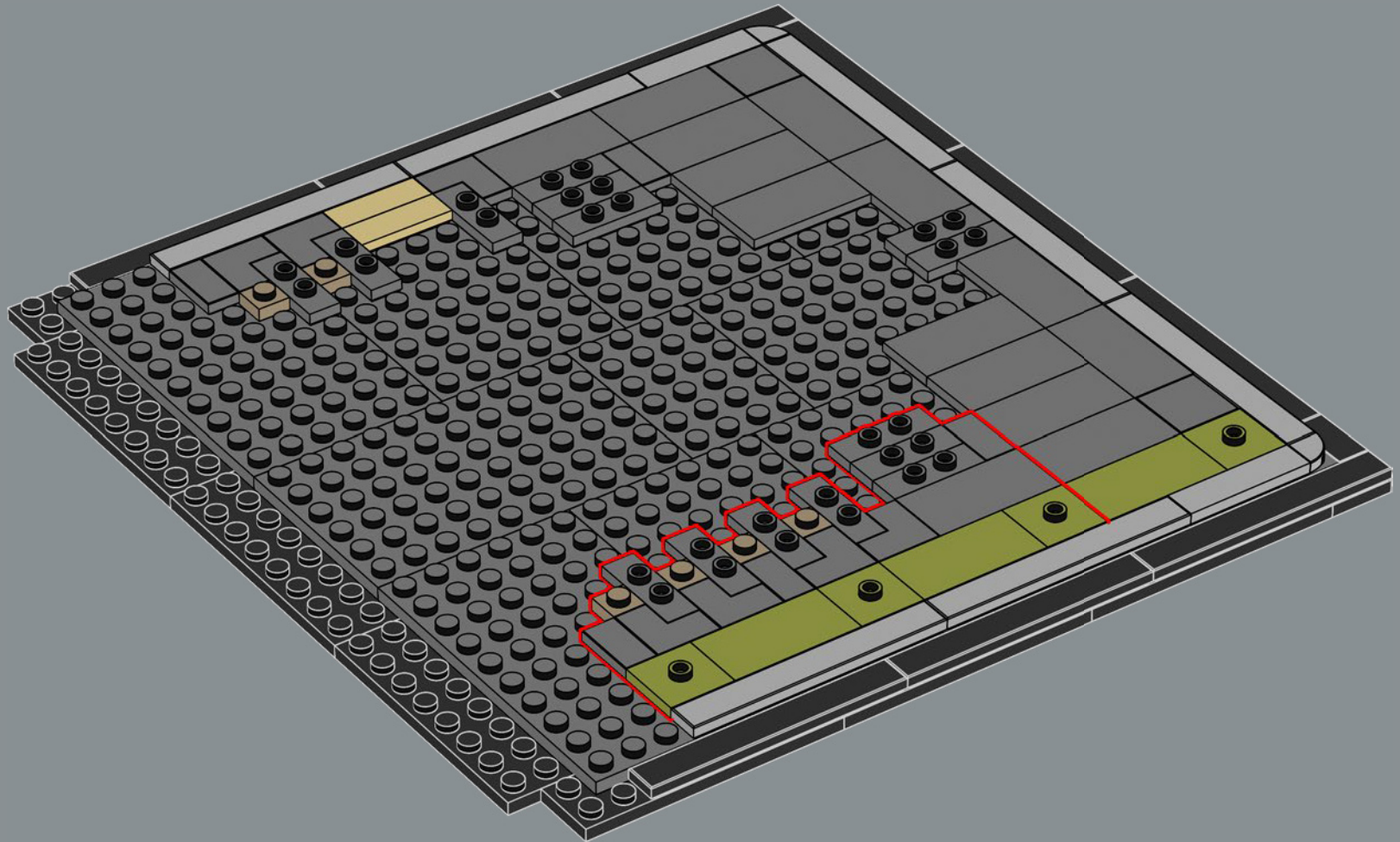

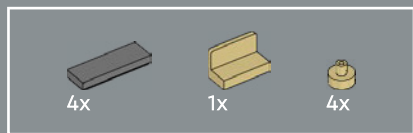

17

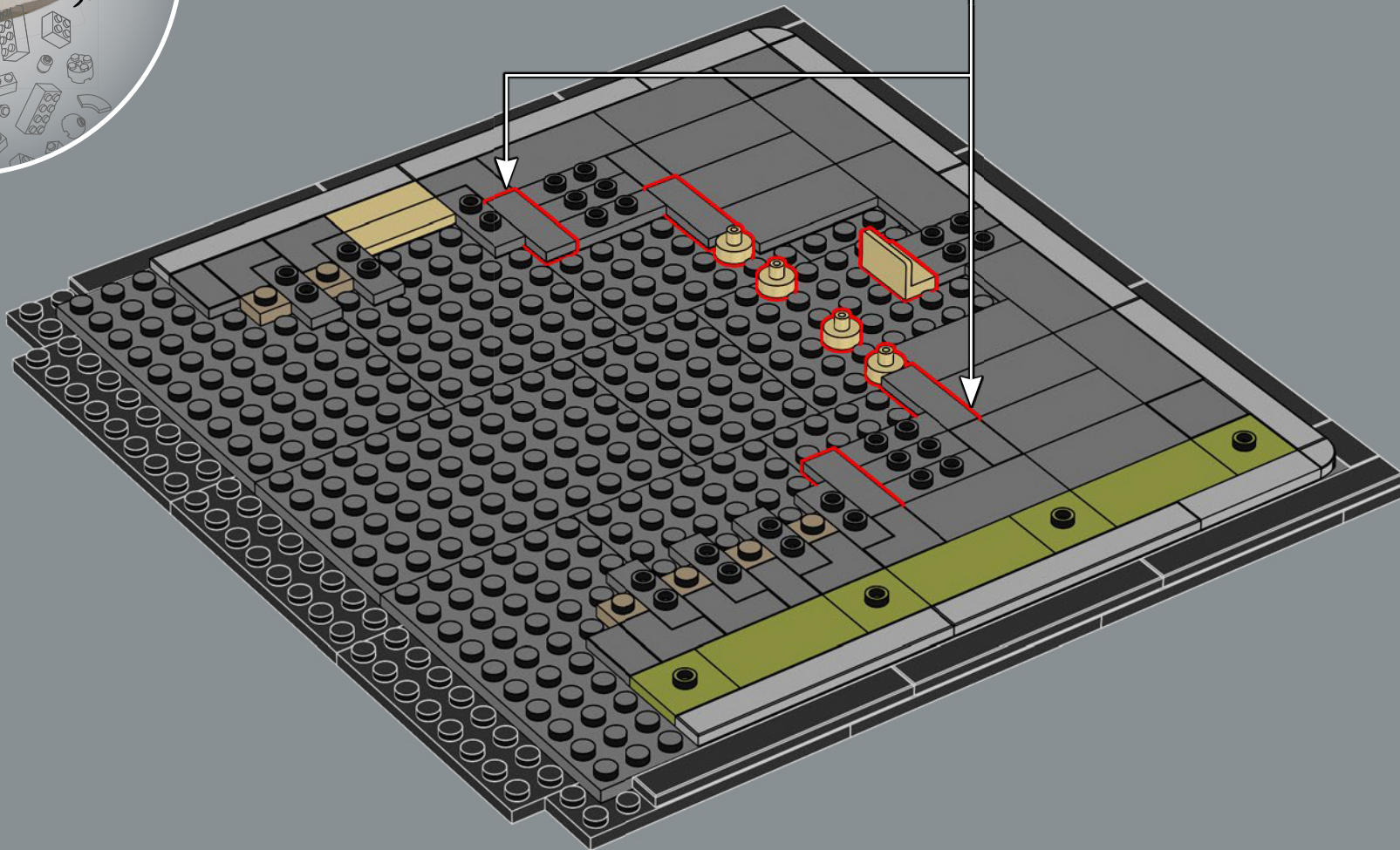
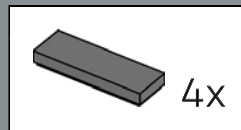



18

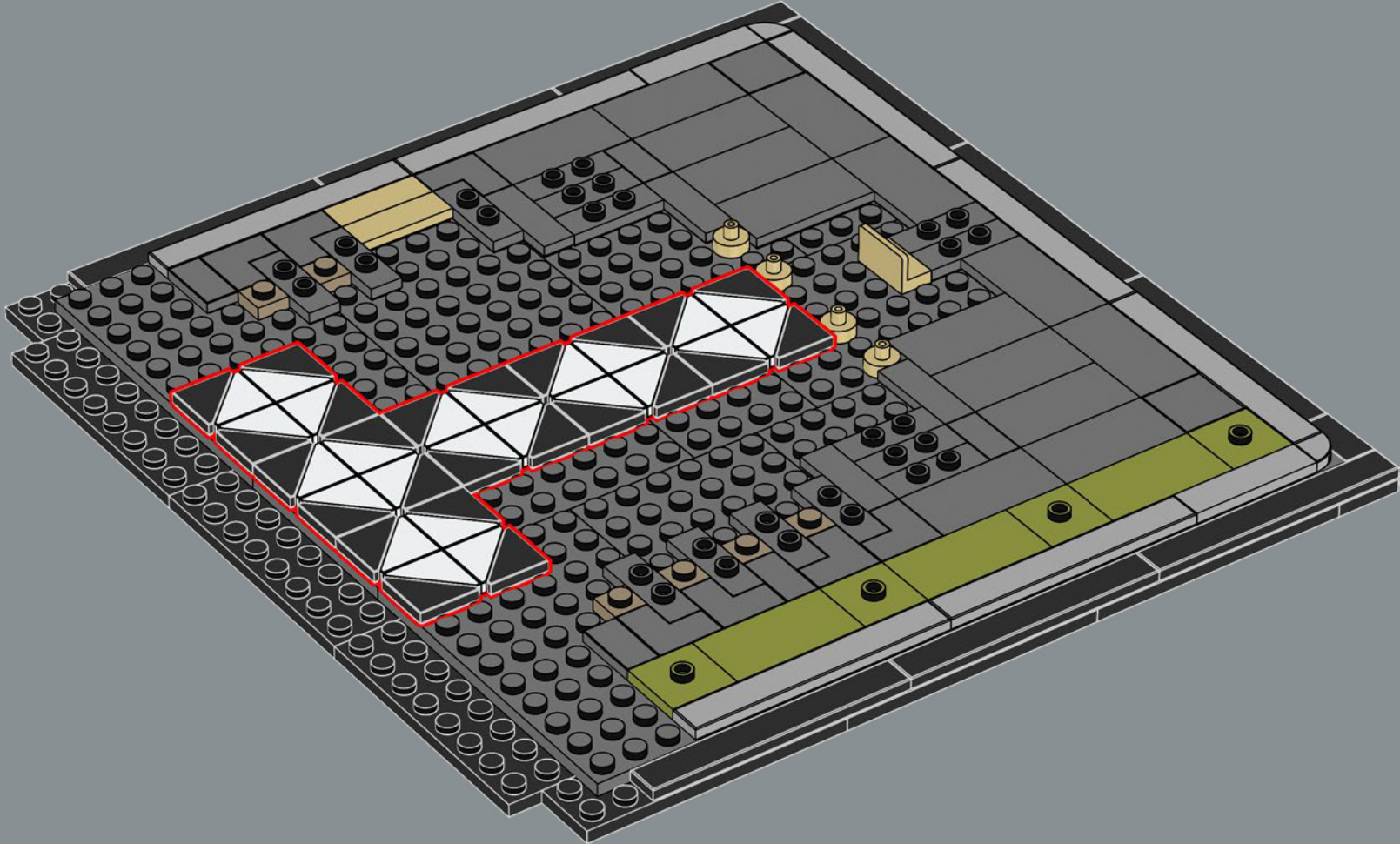



20x

19

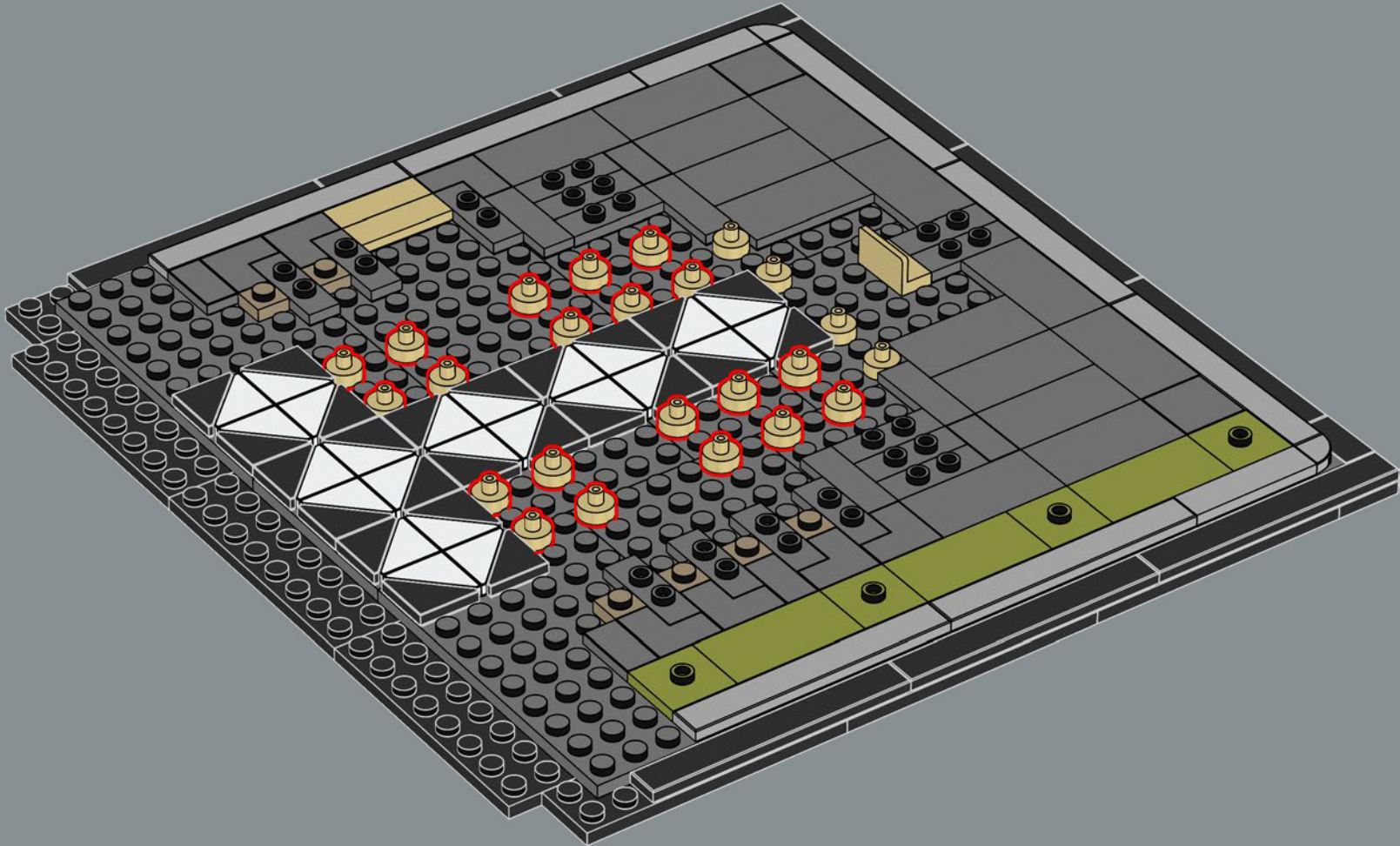

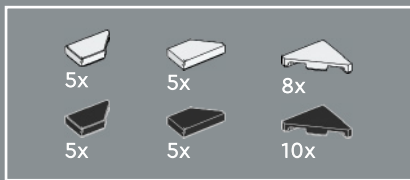

20

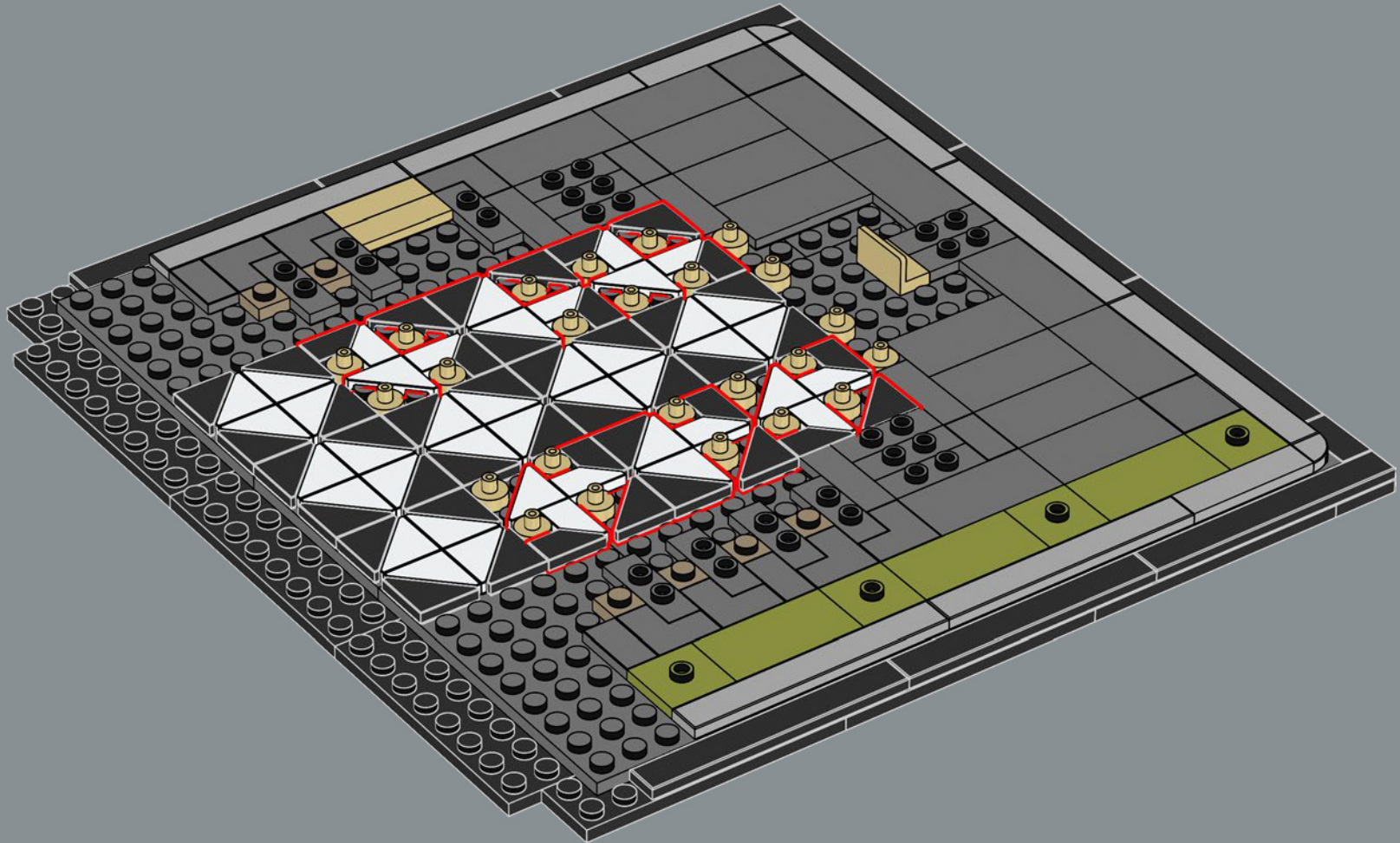

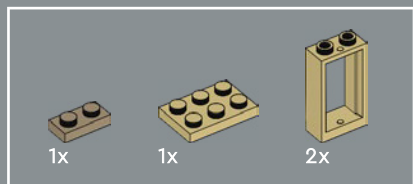

21

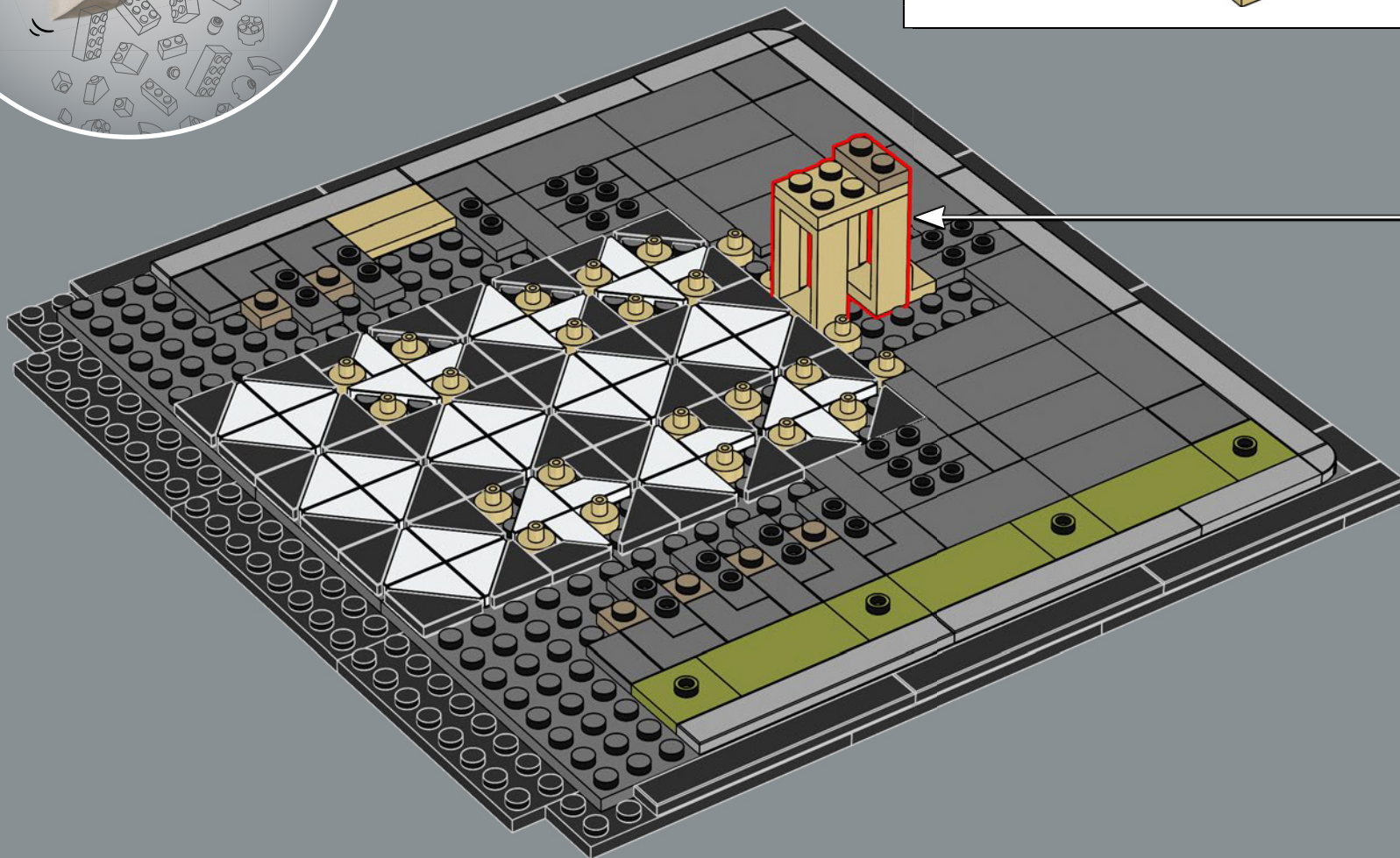
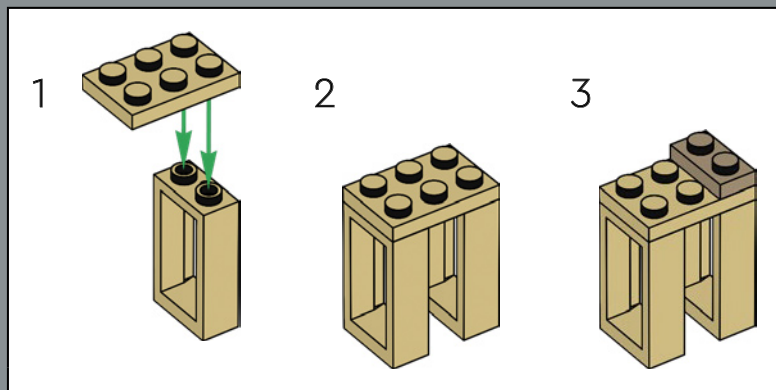

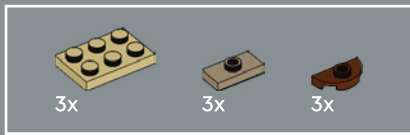

22

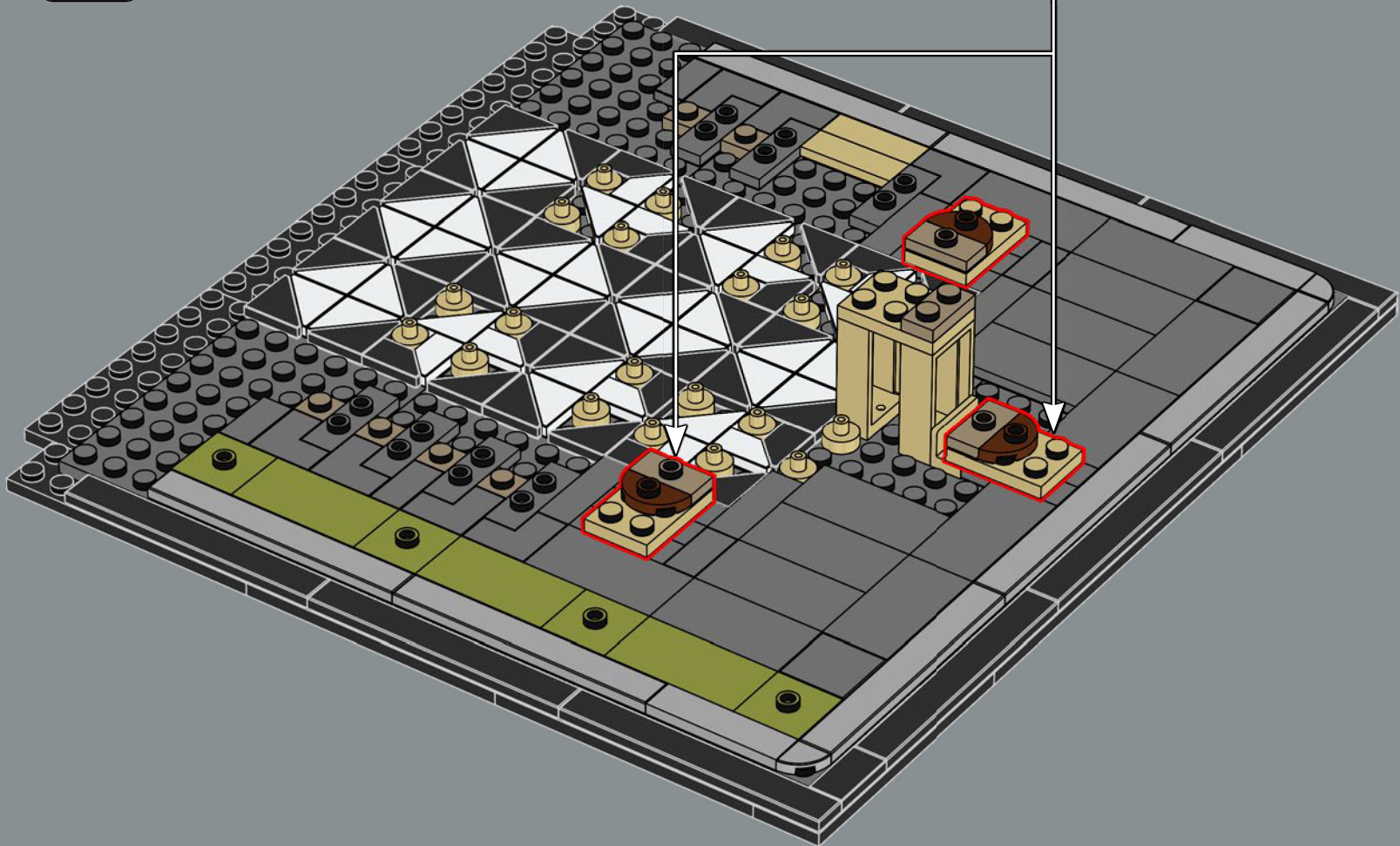
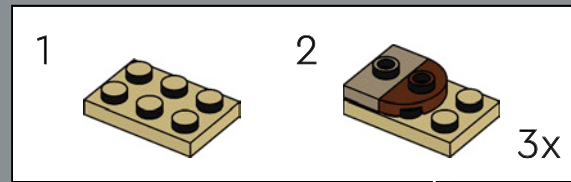

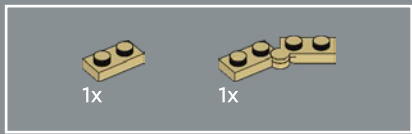

23

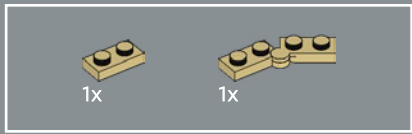
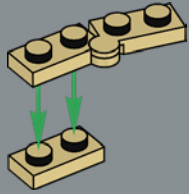

24

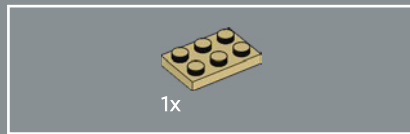
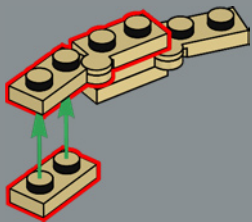

25

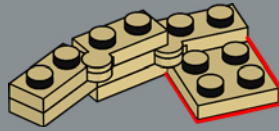

26

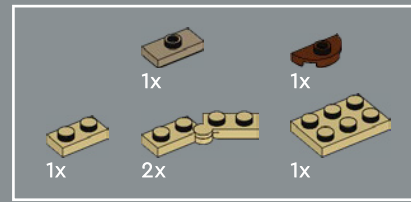
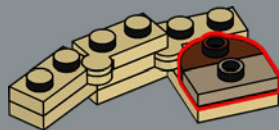

27

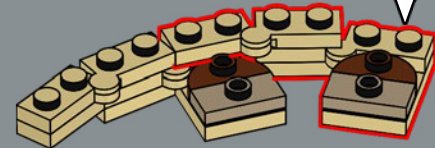
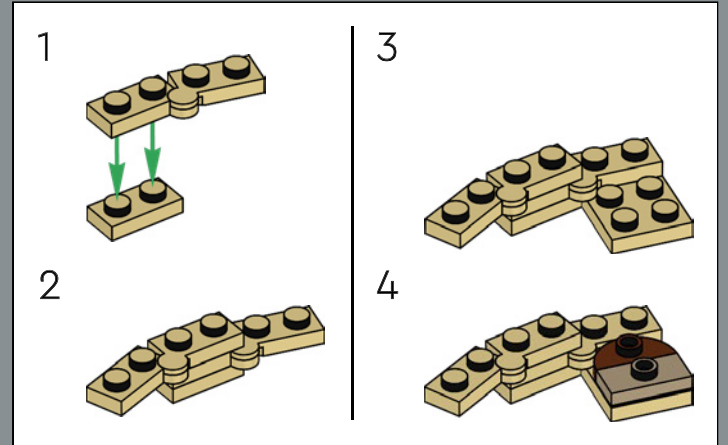

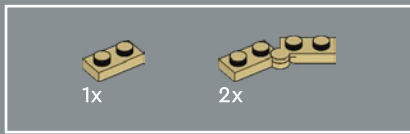

28

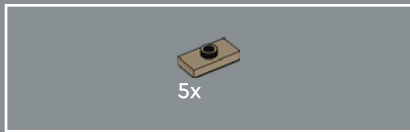
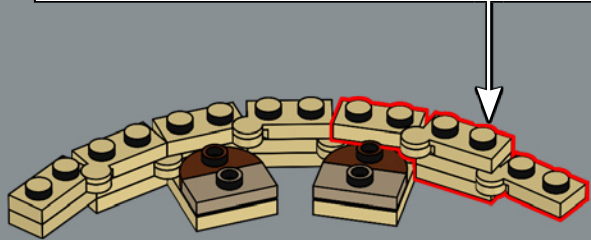
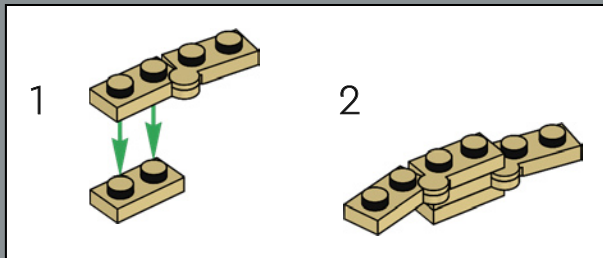

29

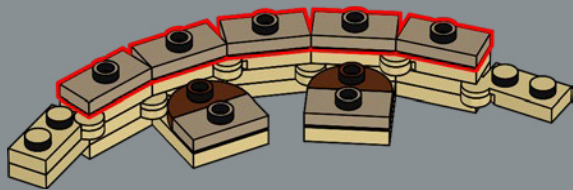

30

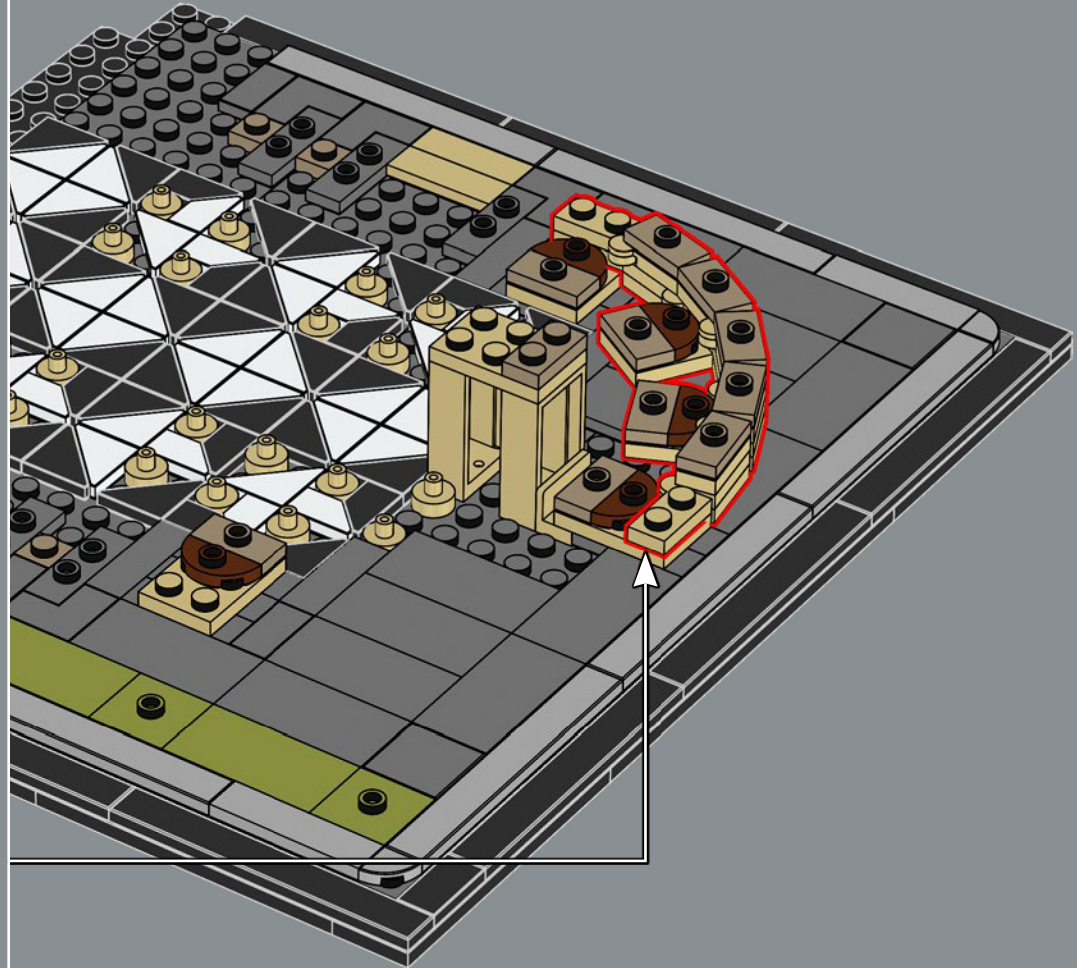

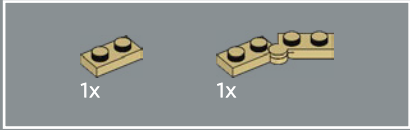
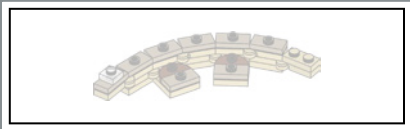

31

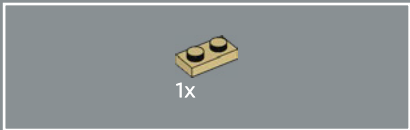
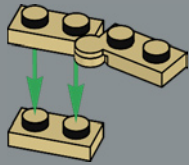

32

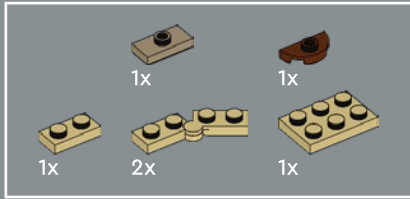

33

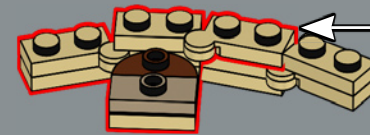
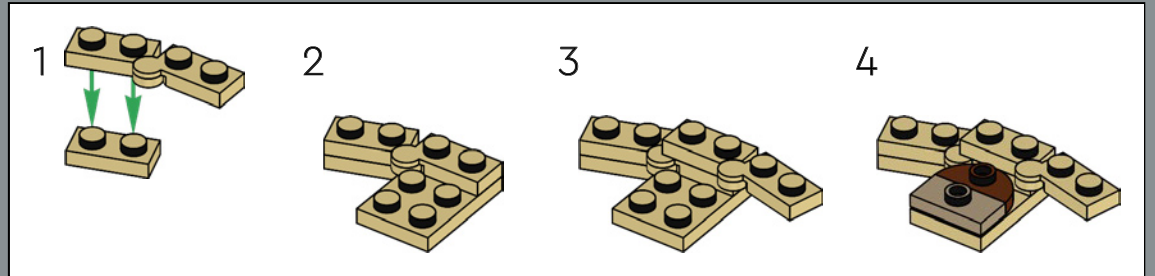

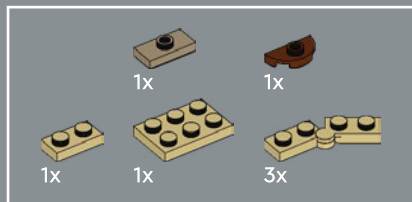

34

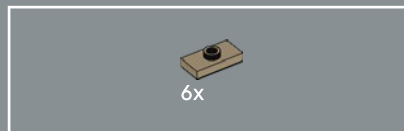
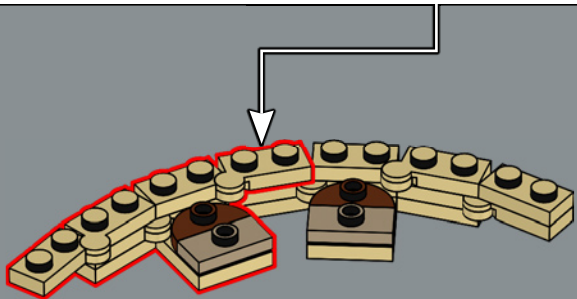
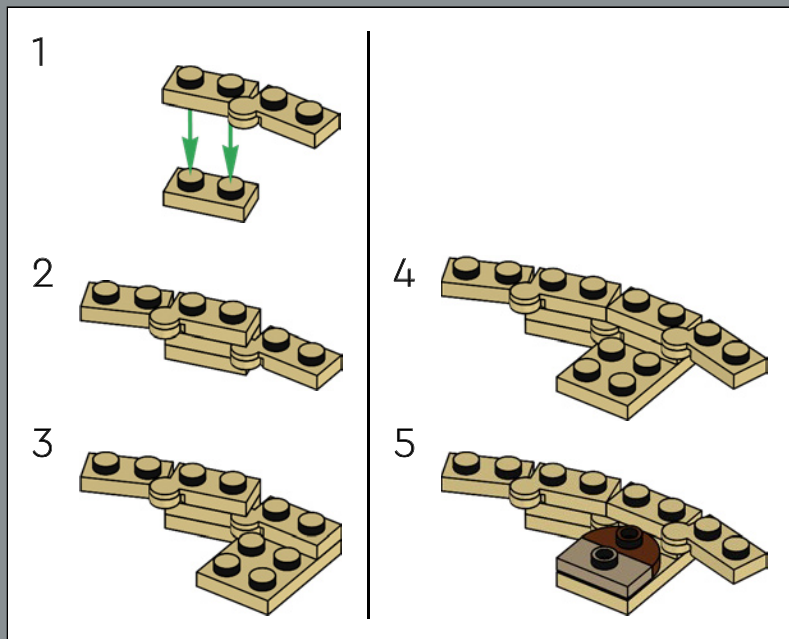

35

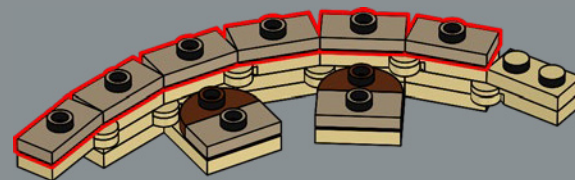

36

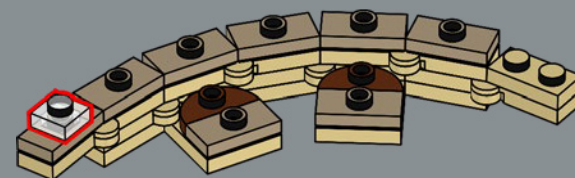

1163 – Les éléments du plan au sol sont déterminés par une série de cercles, tracés à l'aide de cordes de différentes longueurs, elles-mêmes fixées à un pieu au centre de la cathédrale.

37

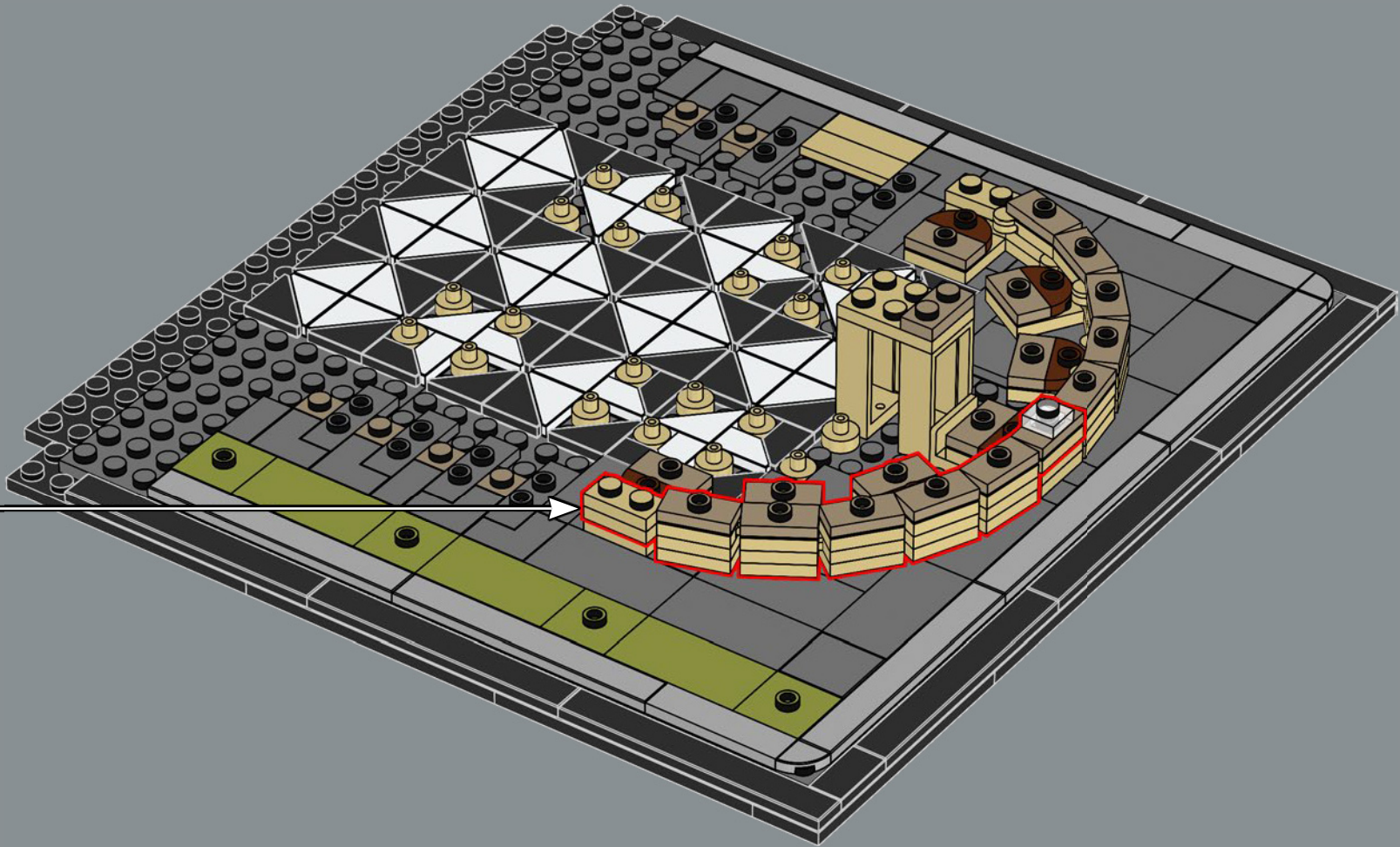

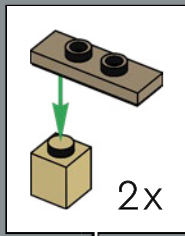
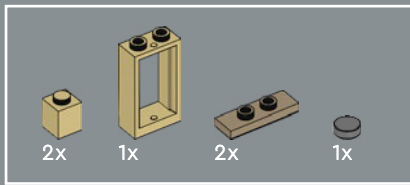

38

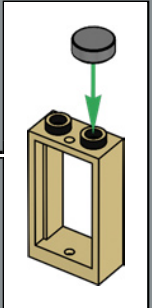
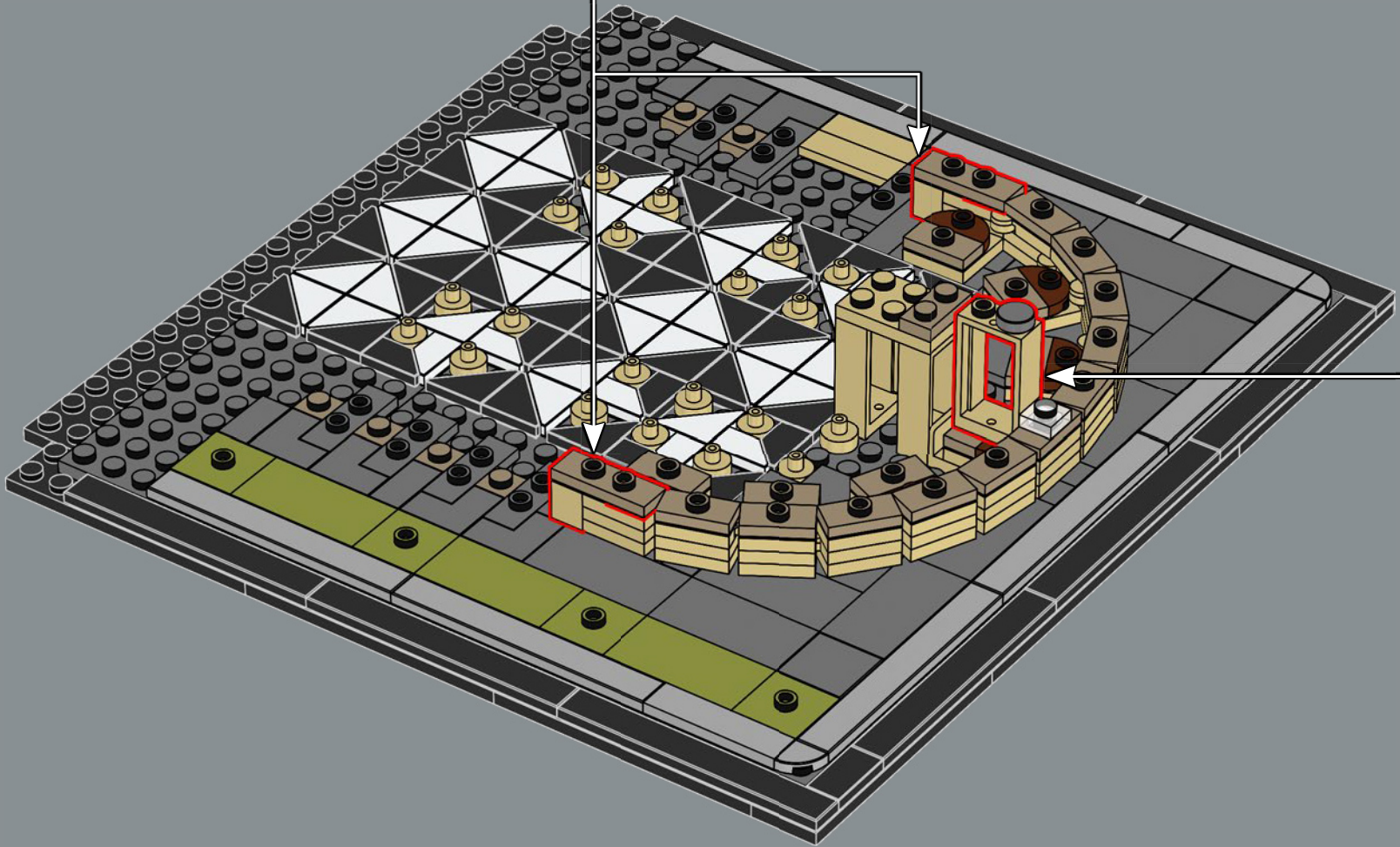

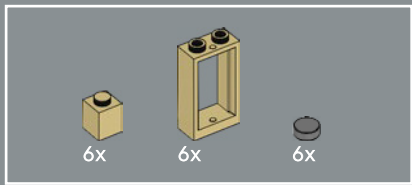

39

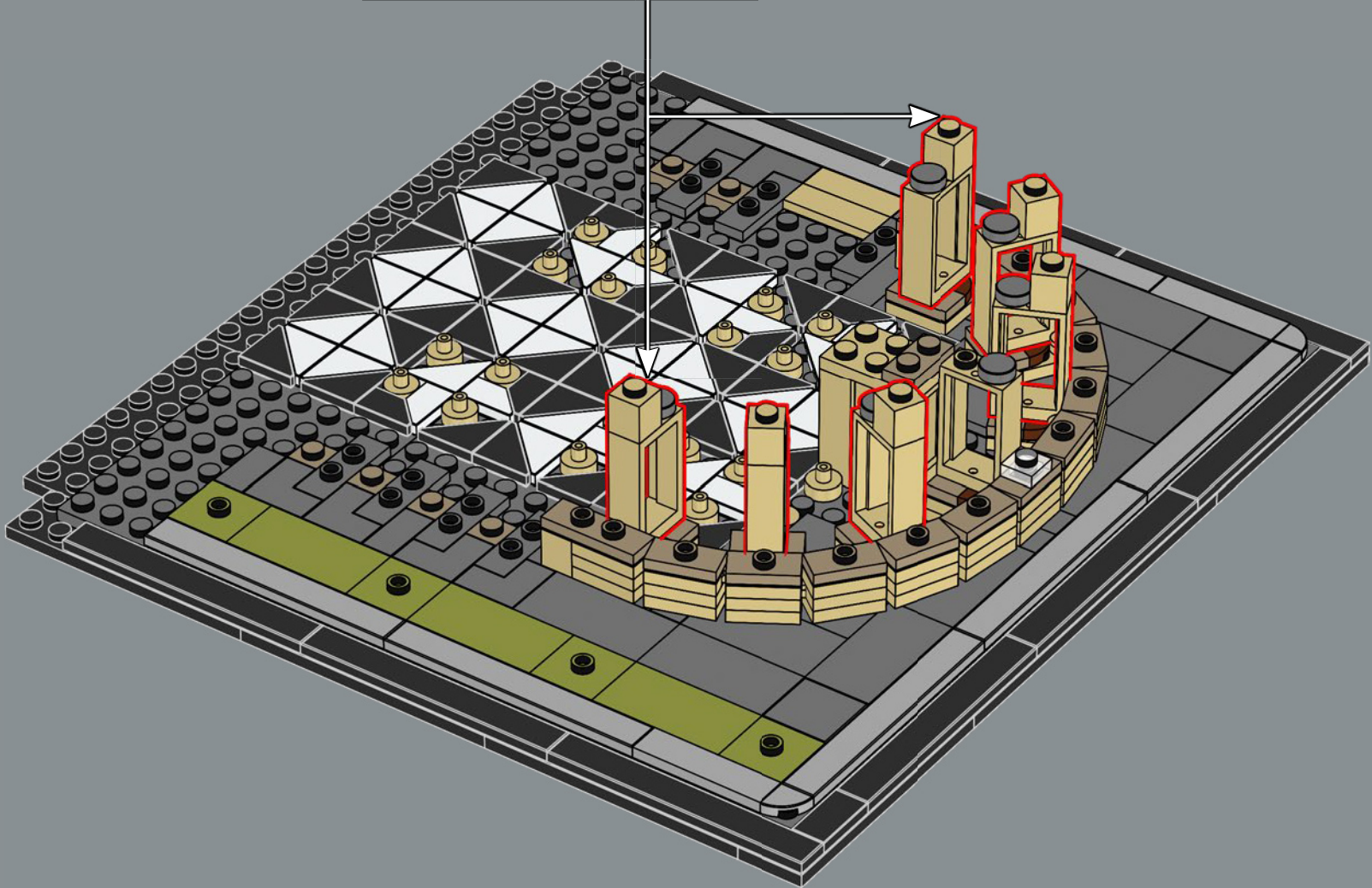
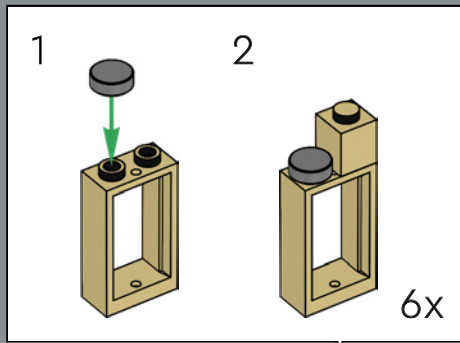



40

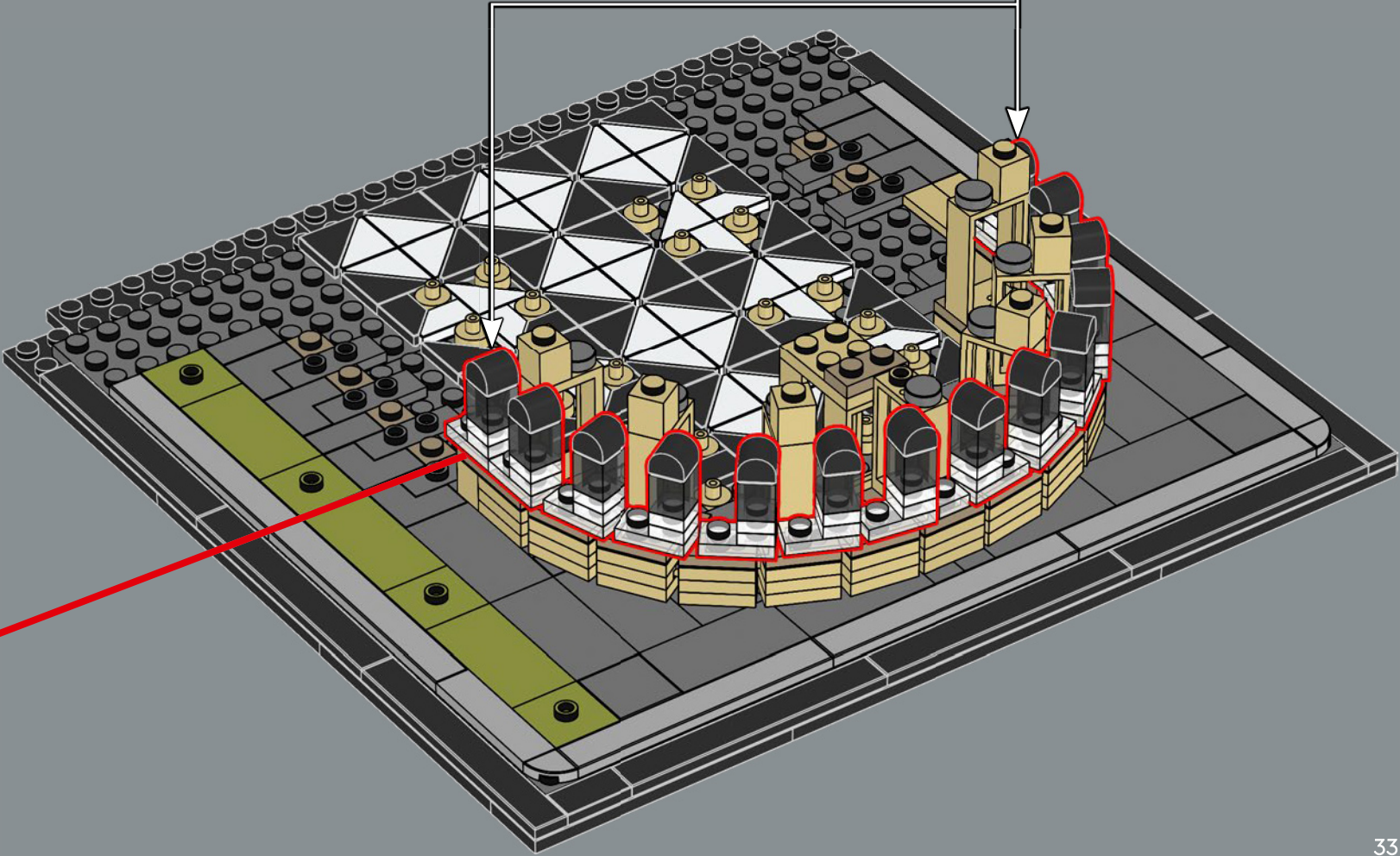
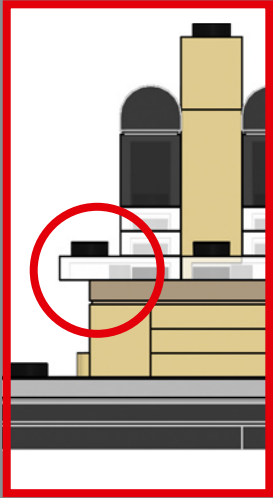
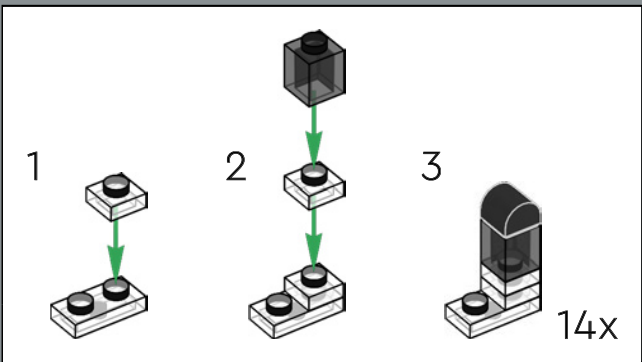

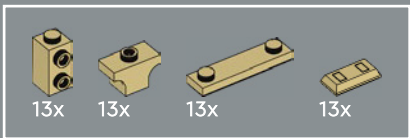

41

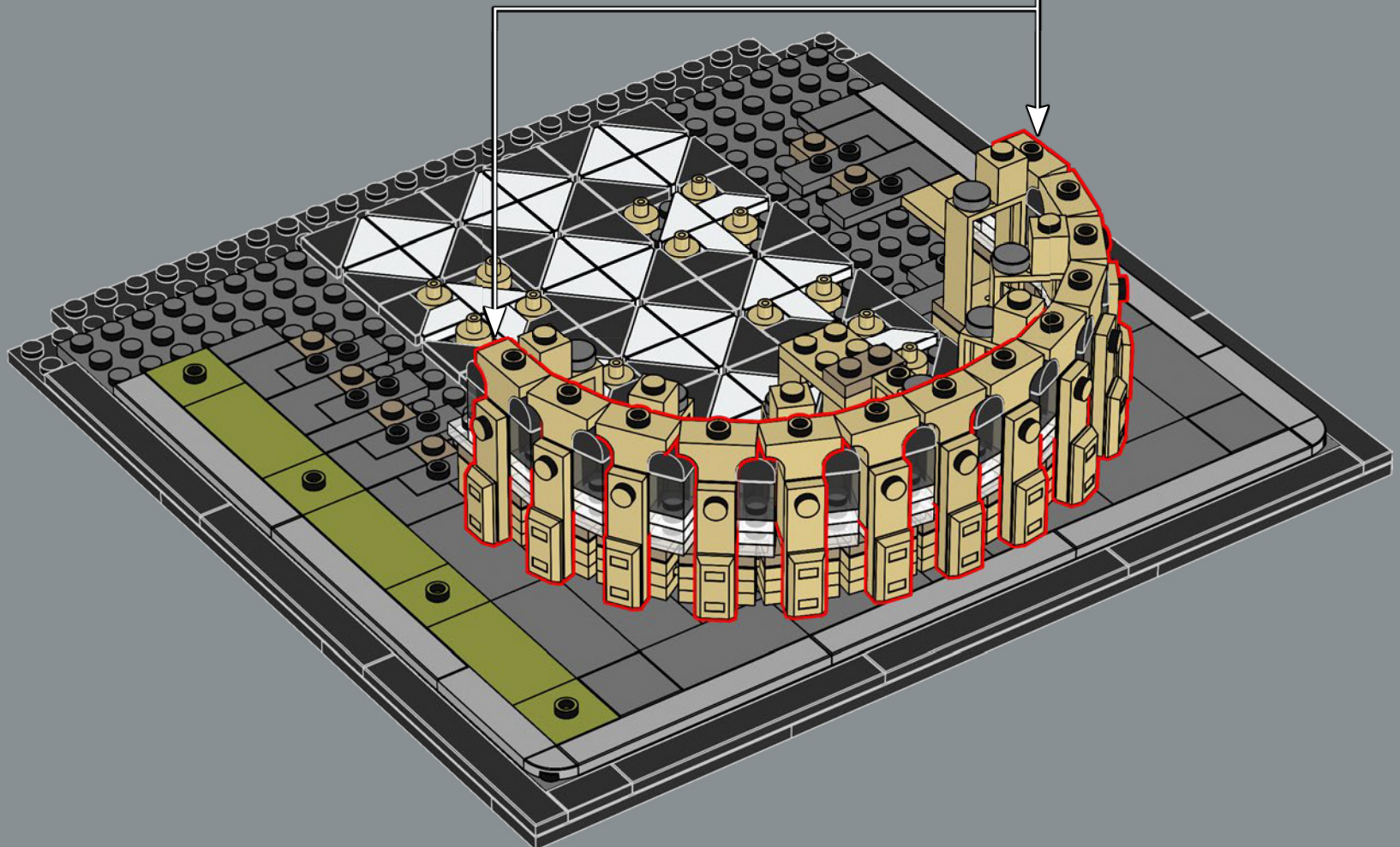
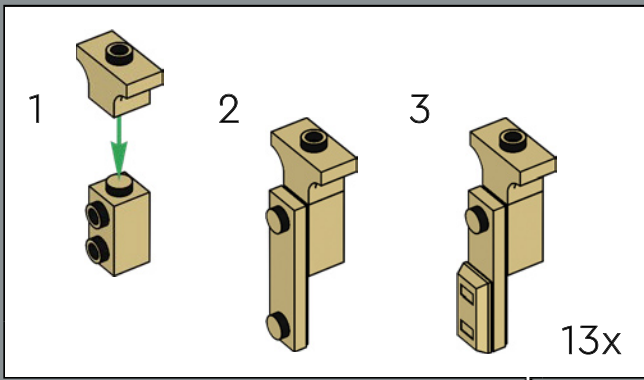

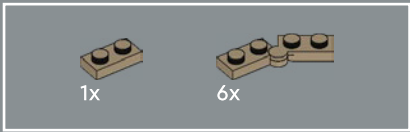

42

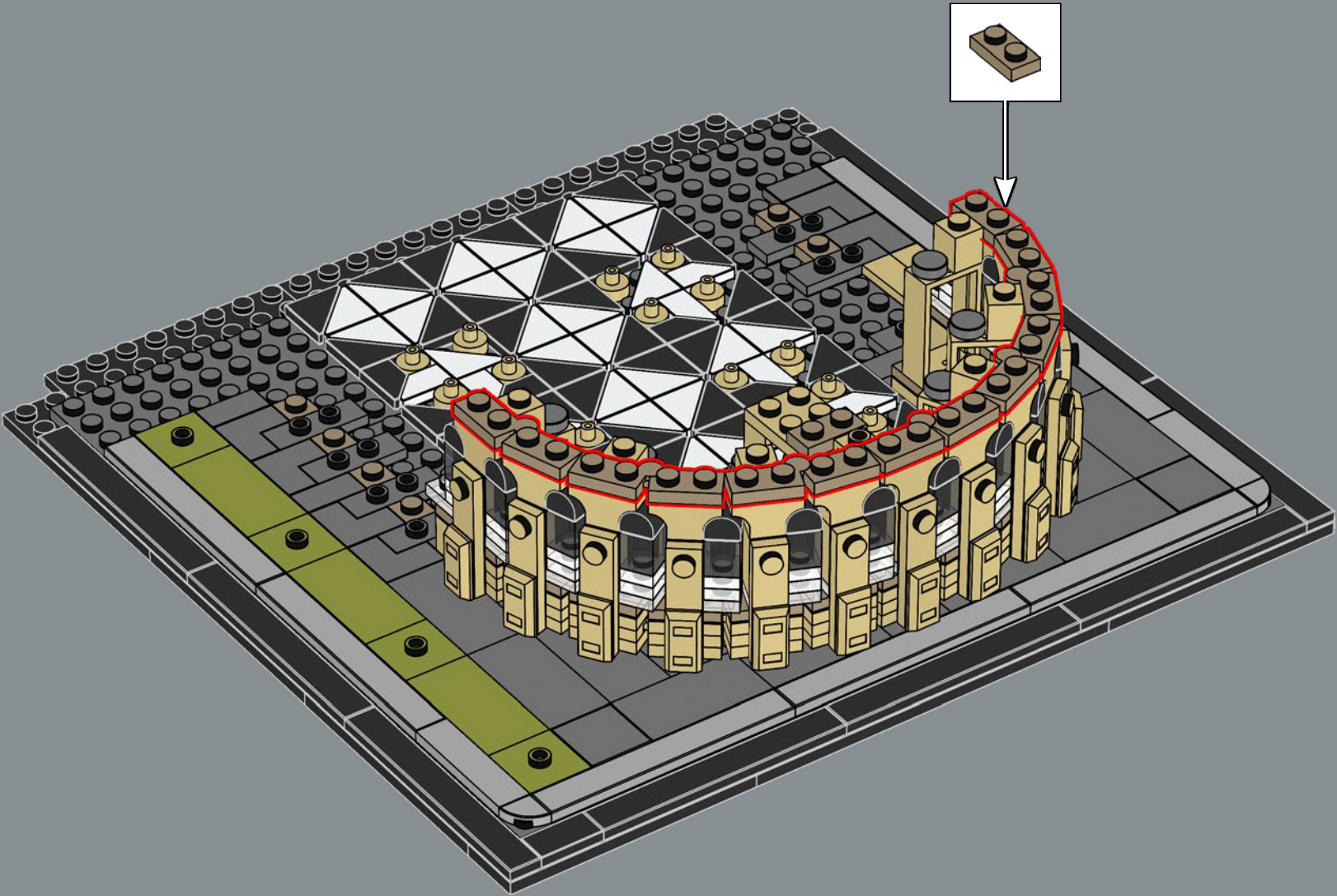

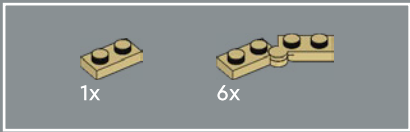

43

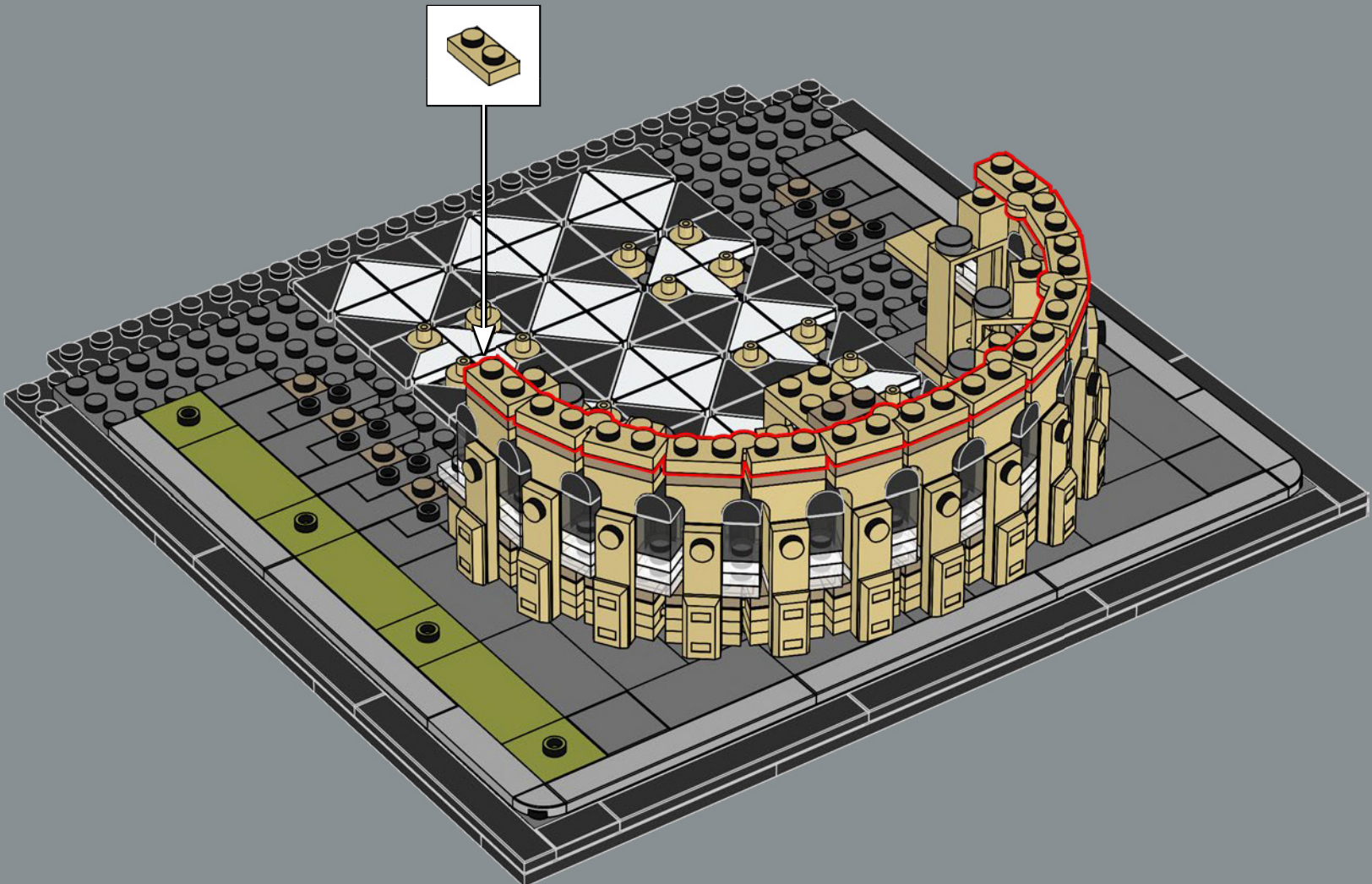

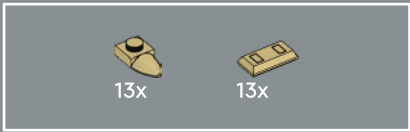

44

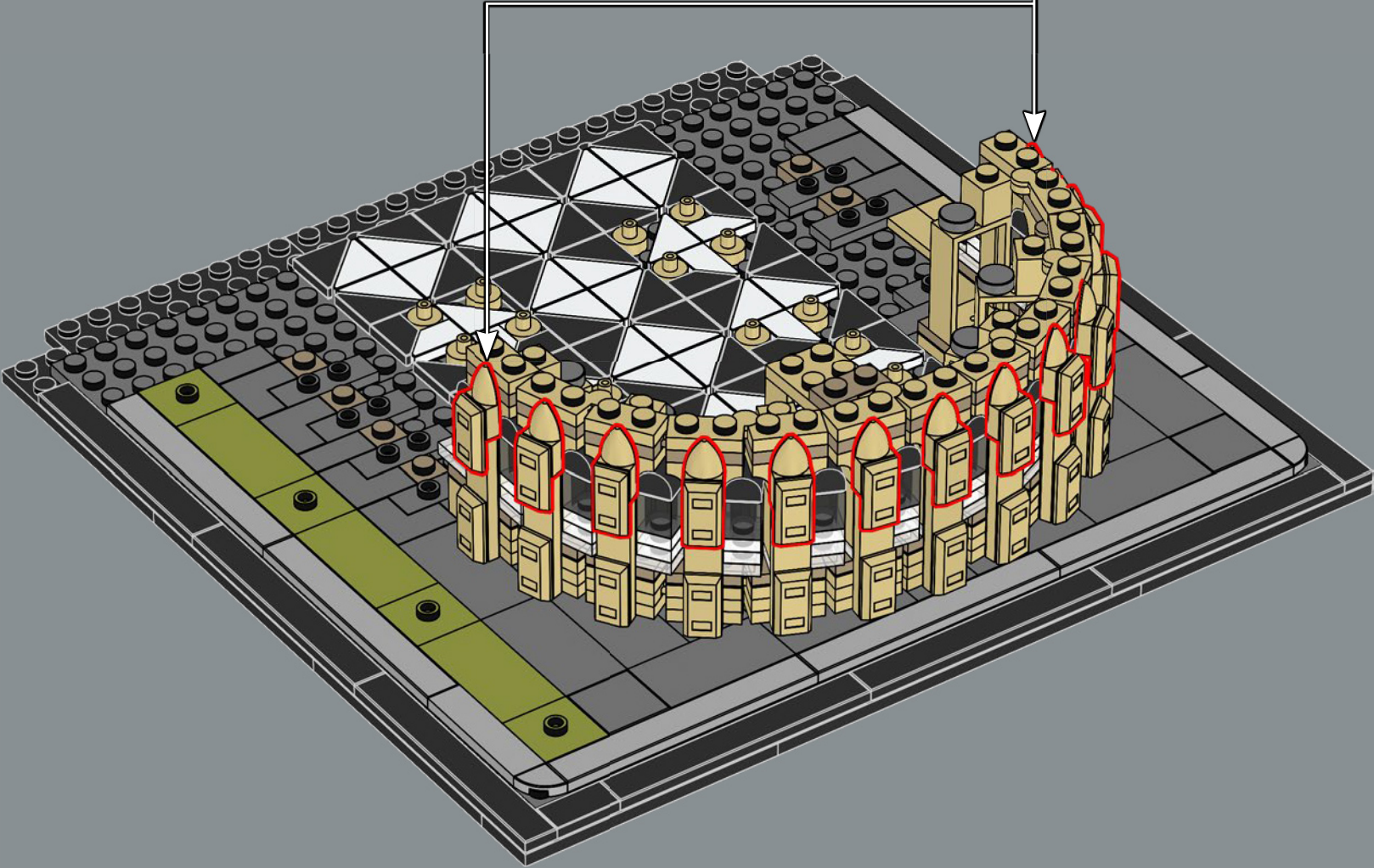
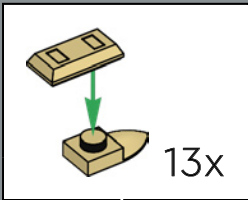

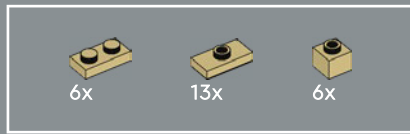

45

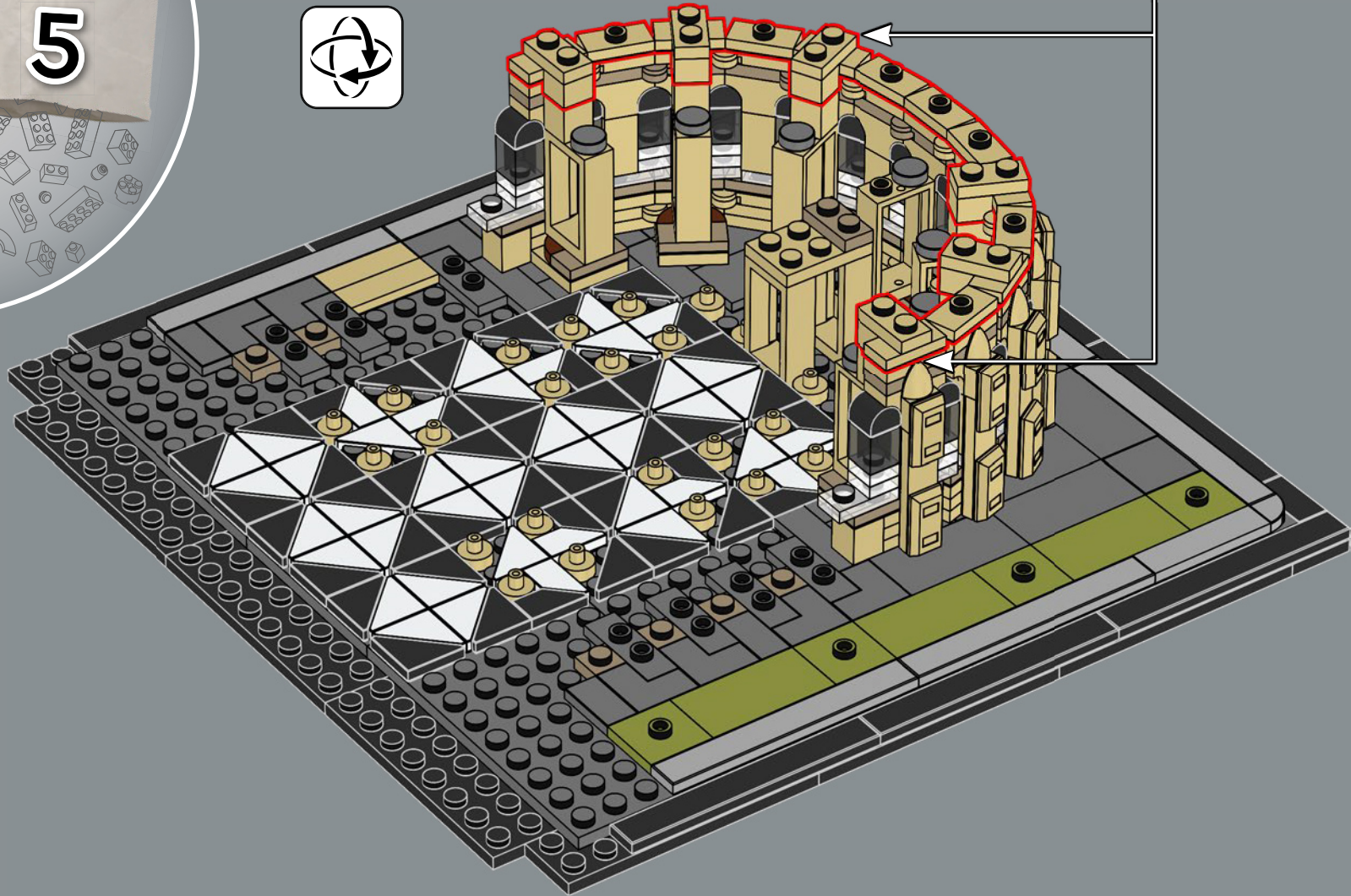
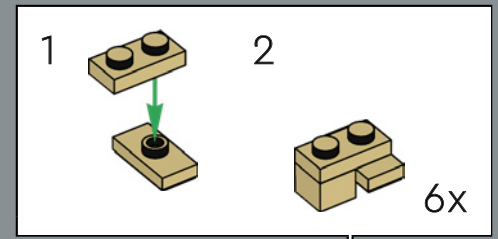

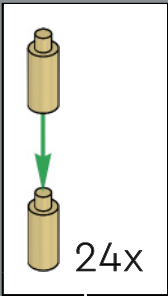

46

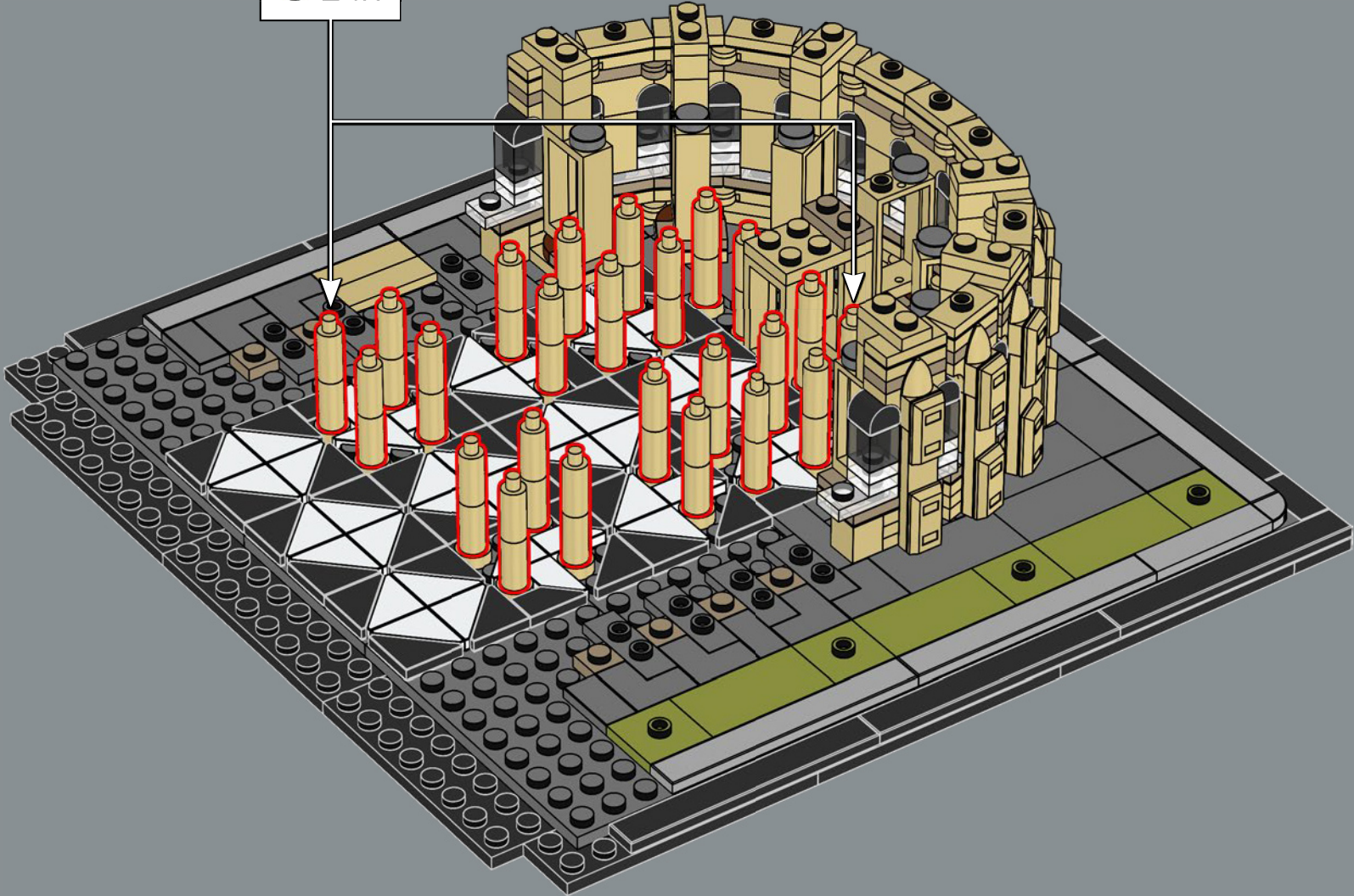

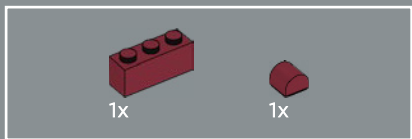

47

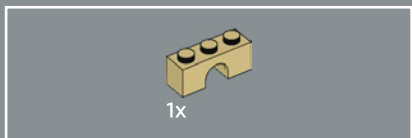
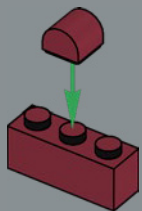

48

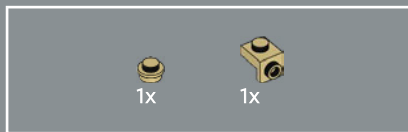
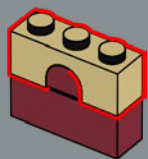

49

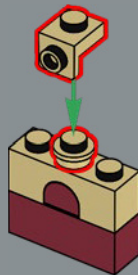

50

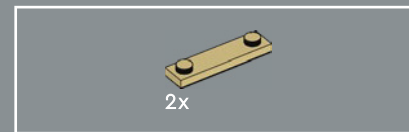
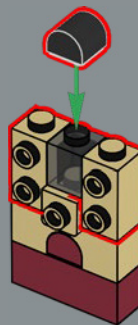

51

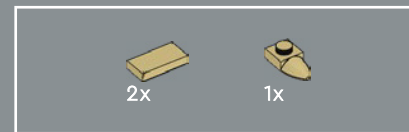

52

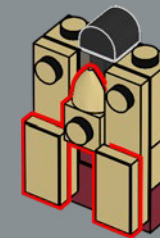

L'élégant portail permettant d'accéder directement au chœur doit son nom à la teinte des vantaux de la porte : la porte rouge. Il a été rénové vers 1270.

53

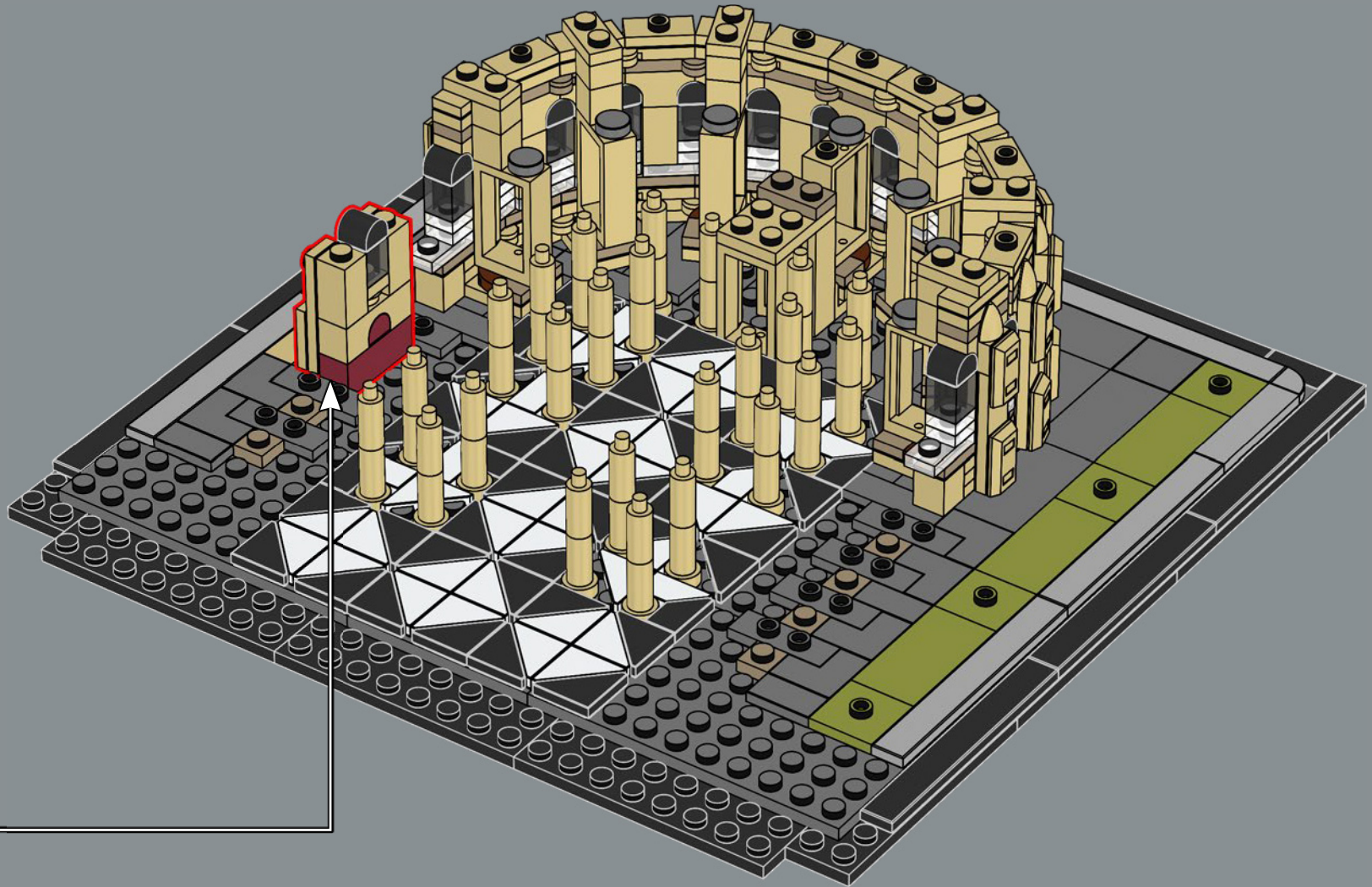

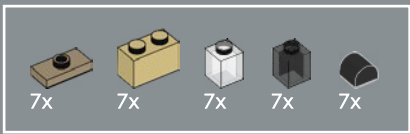

54

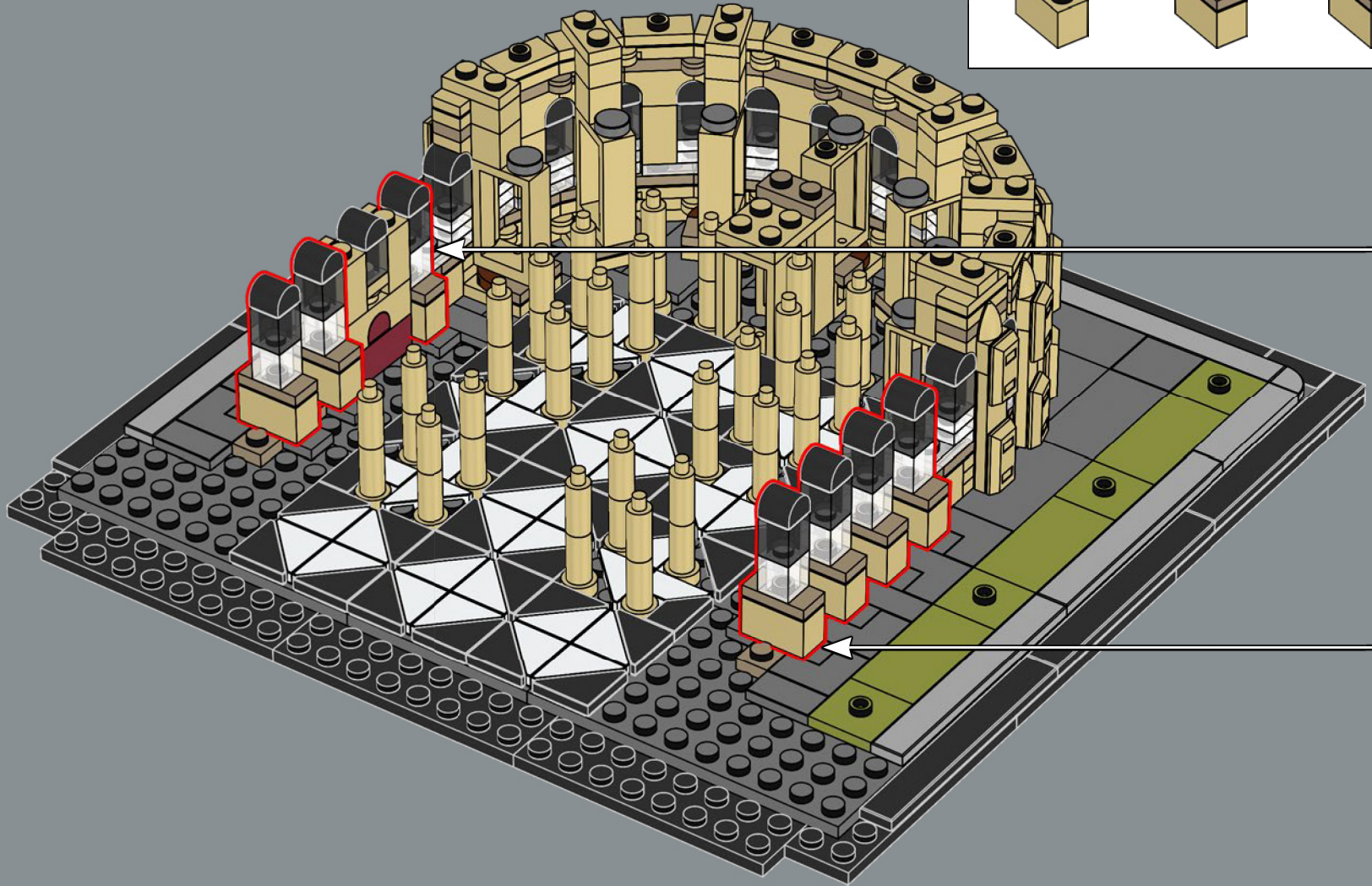
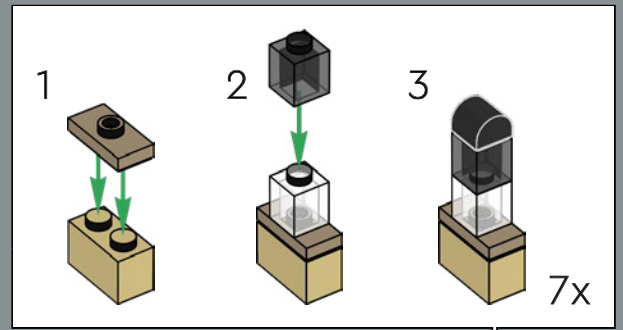

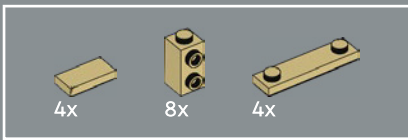

55

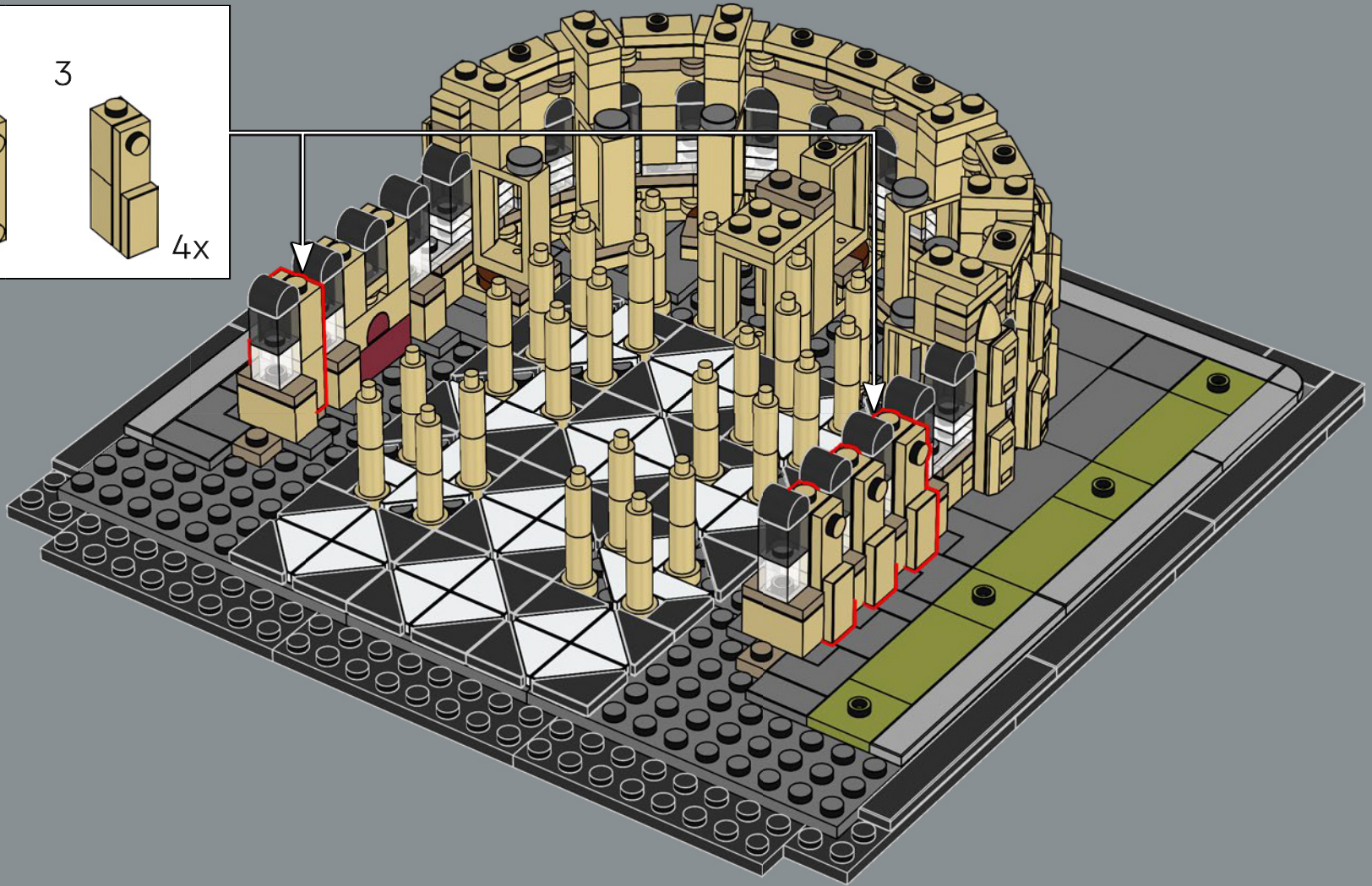
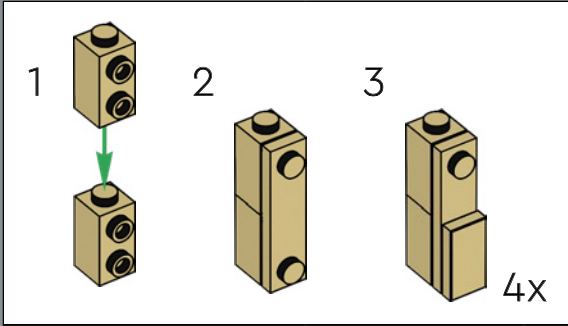

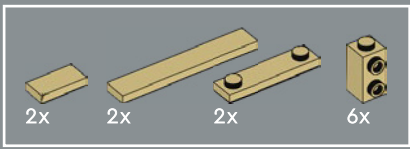

56

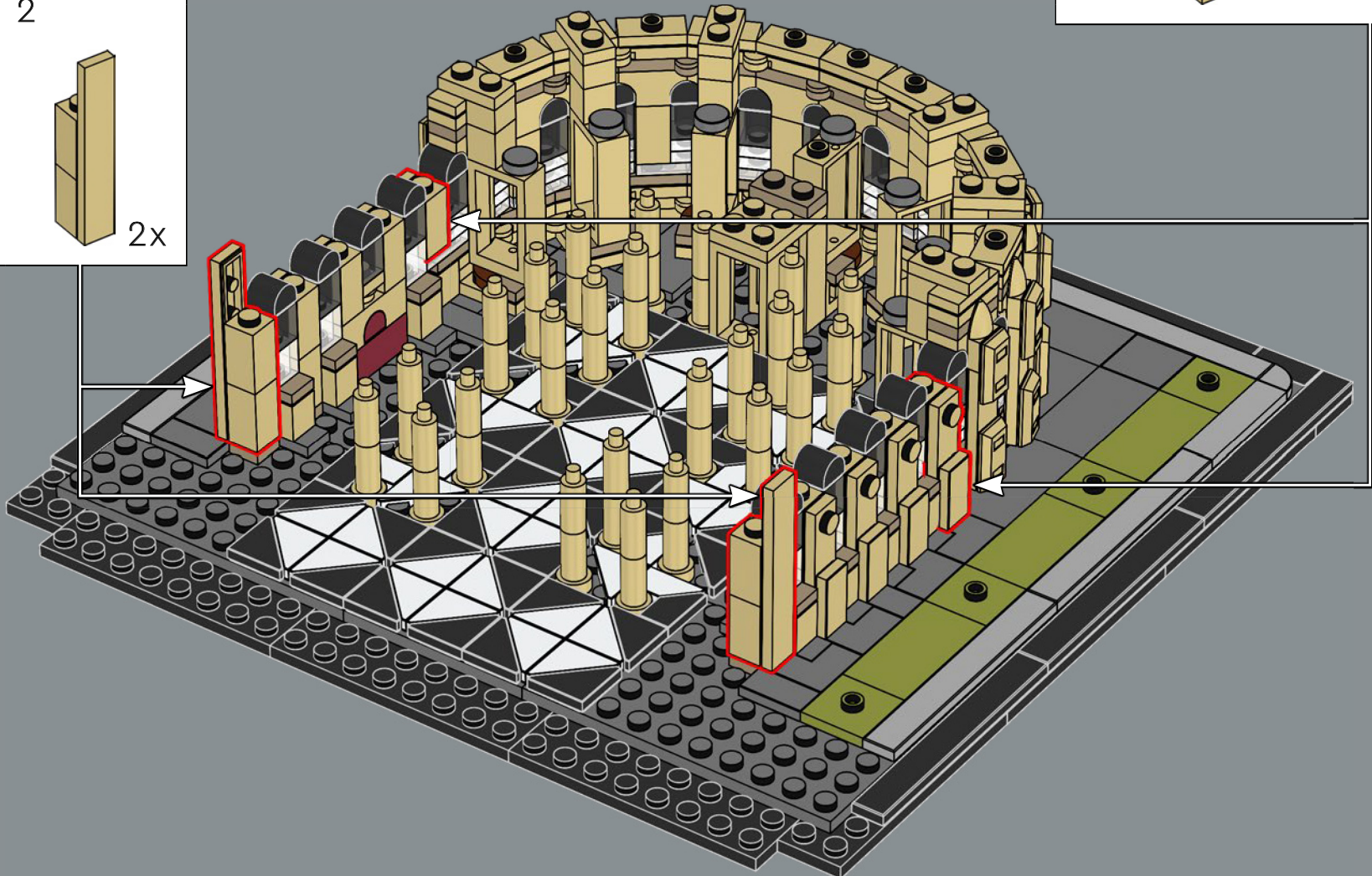
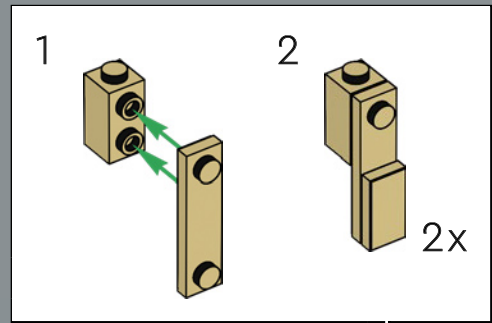
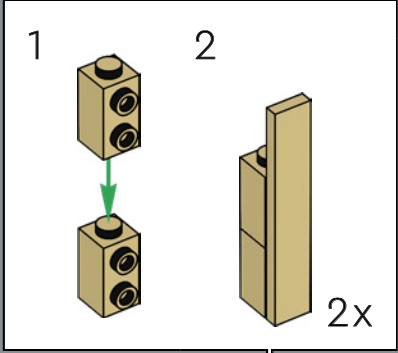

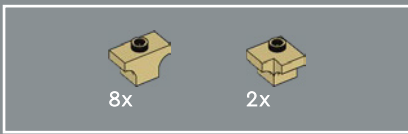

57

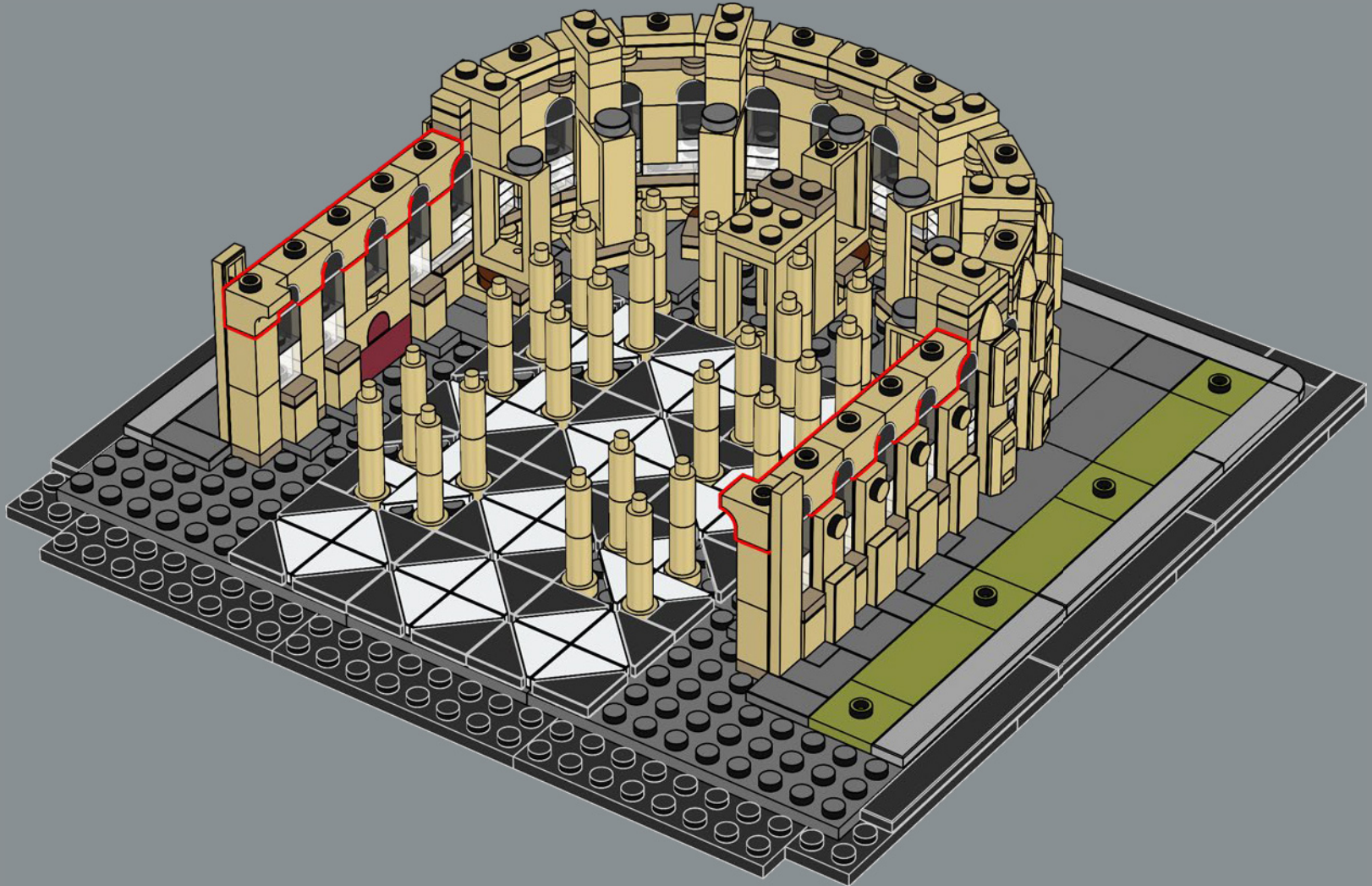

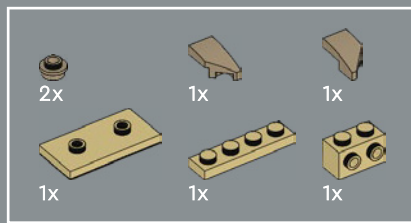

58

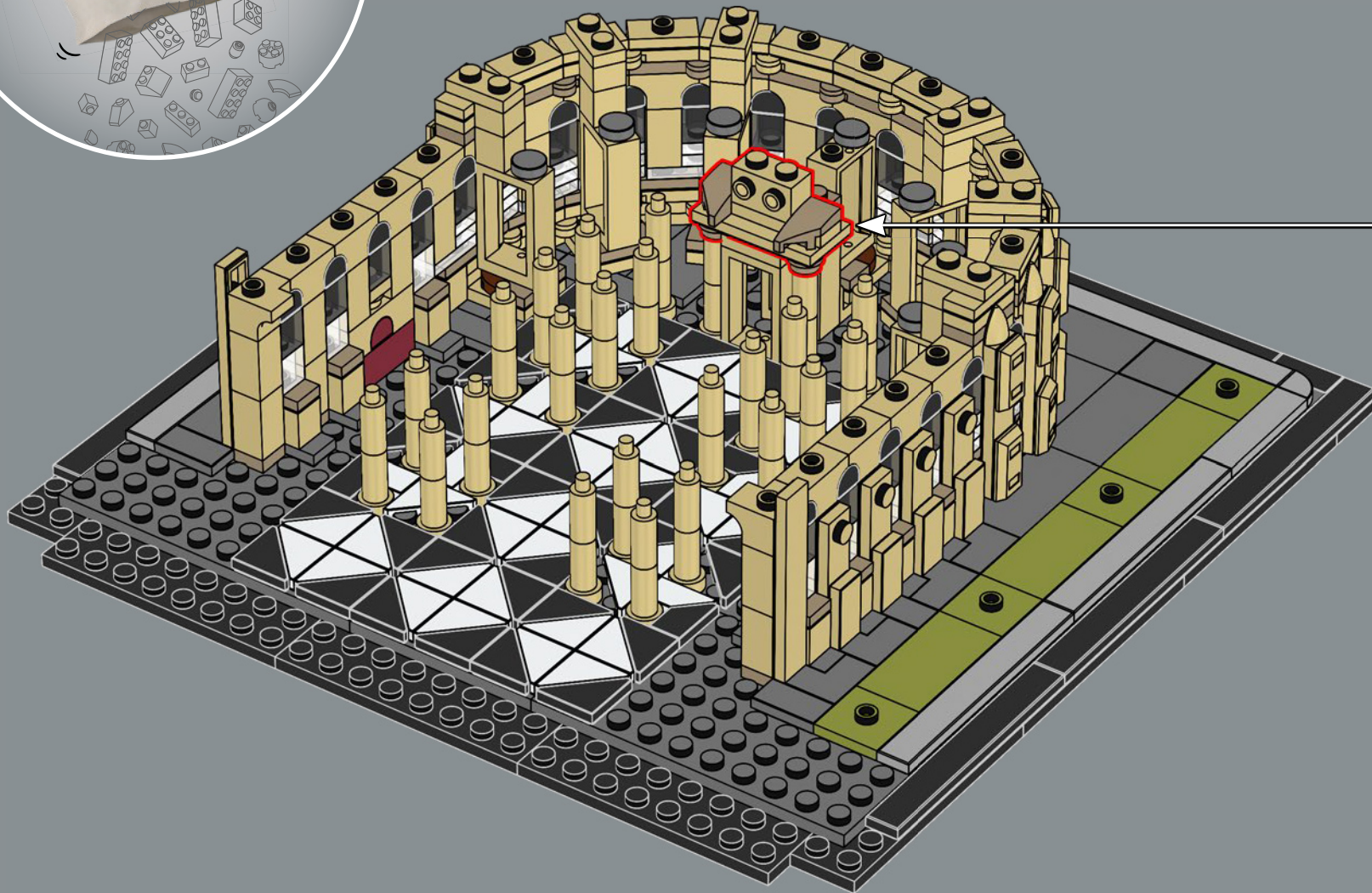
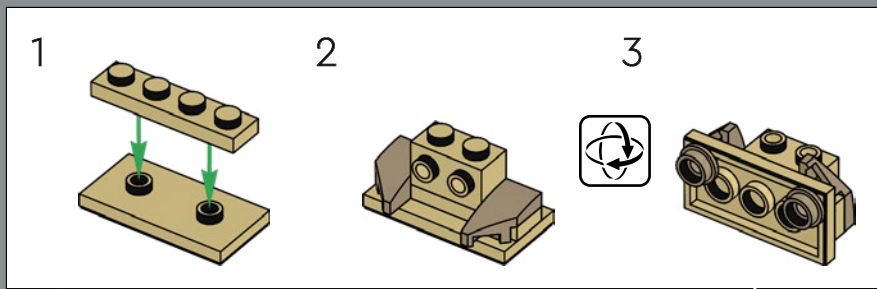

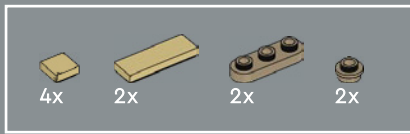

59

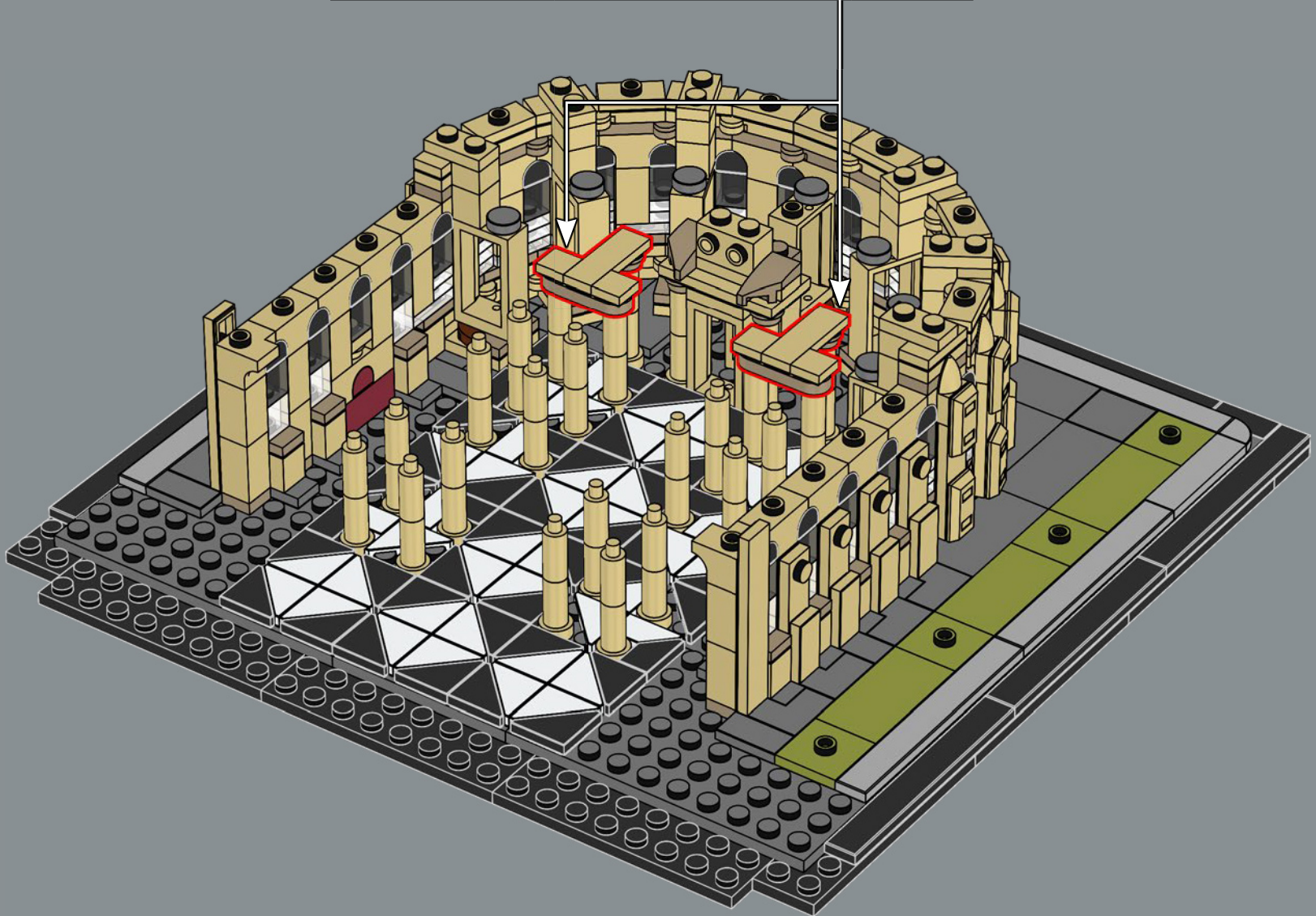
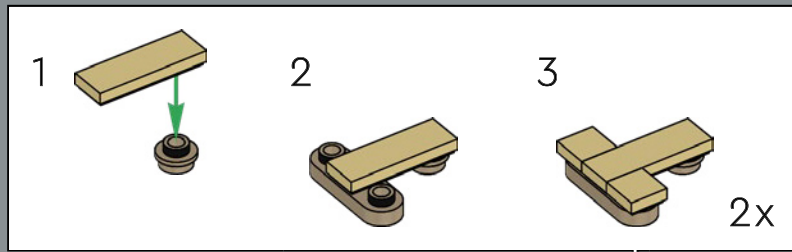

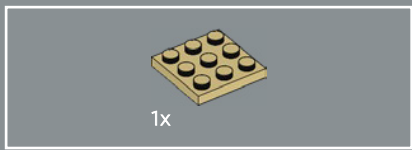

1x

60

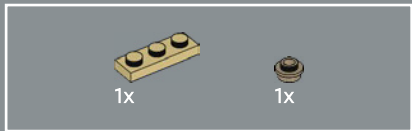

1x

1x

61

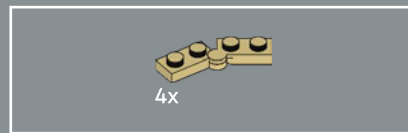
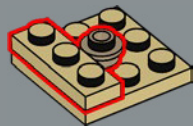

4x

62

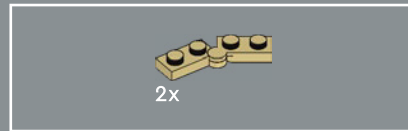
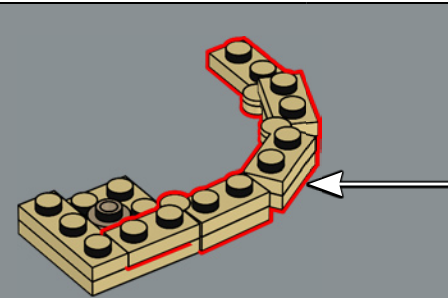
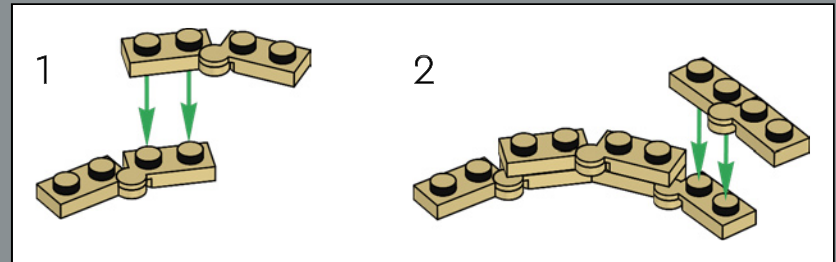

2x

63

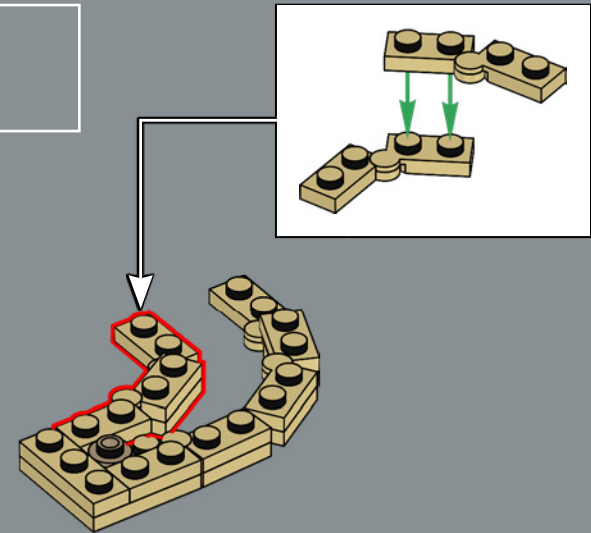

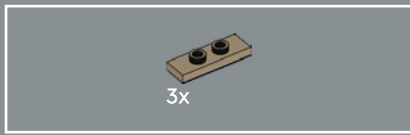

64

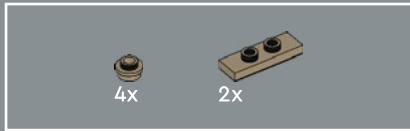
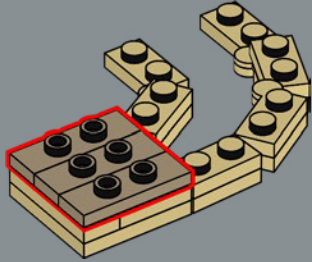

65

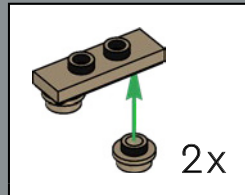
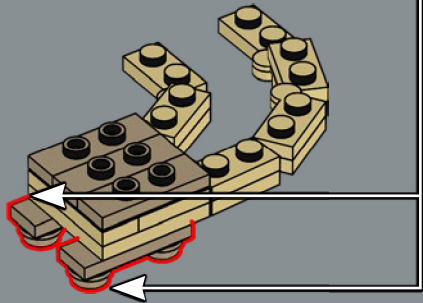

66

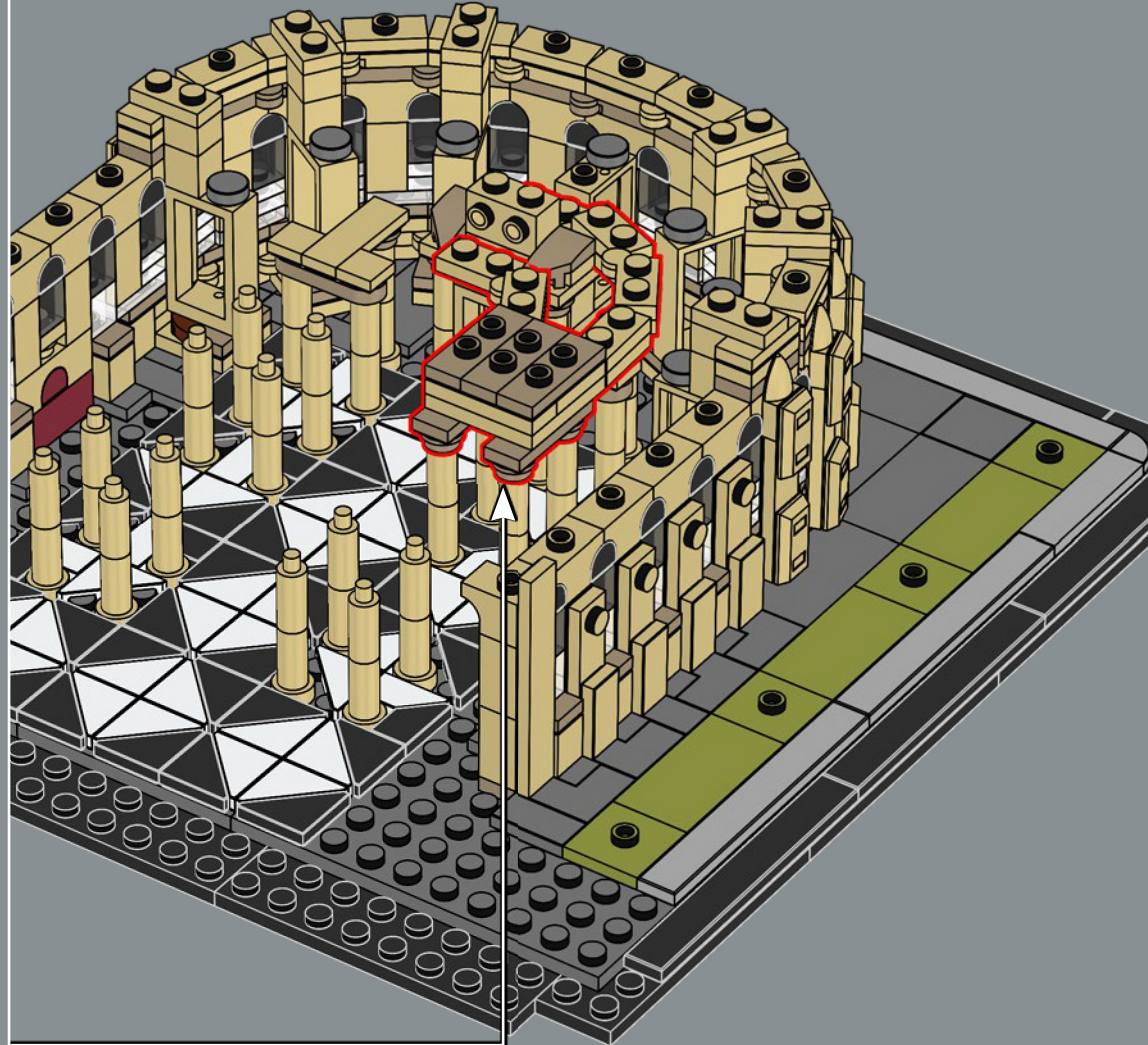

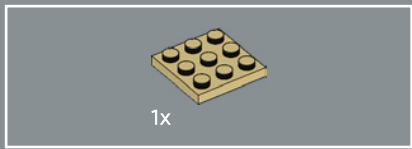

67

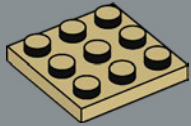

68

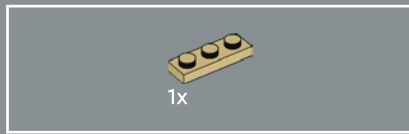
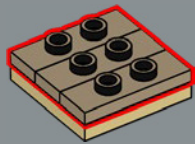

69

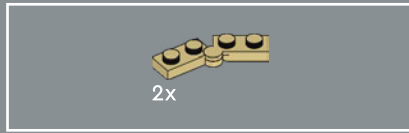
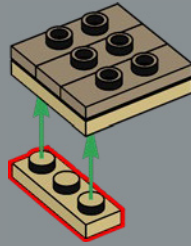

70

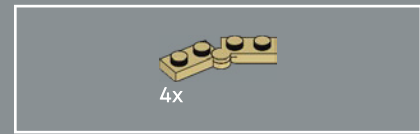
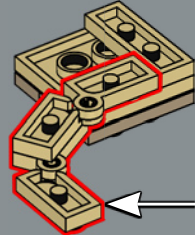
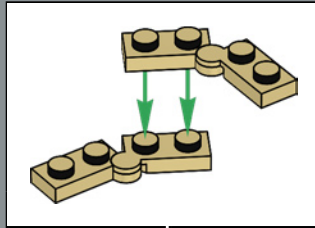

71

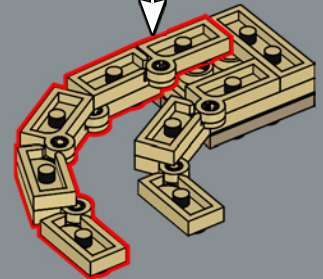
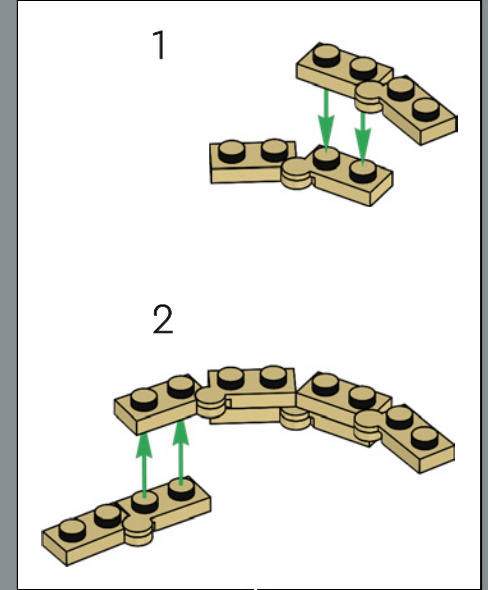

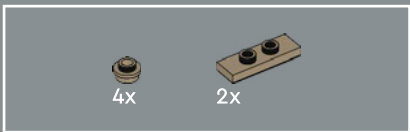

72

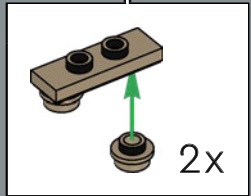
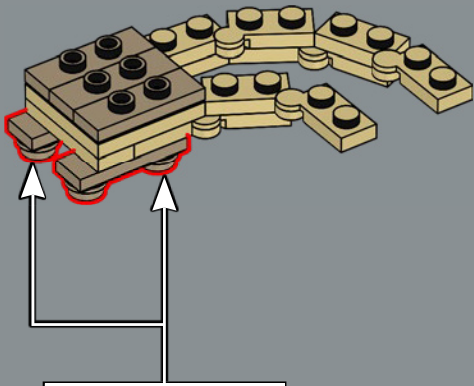

73

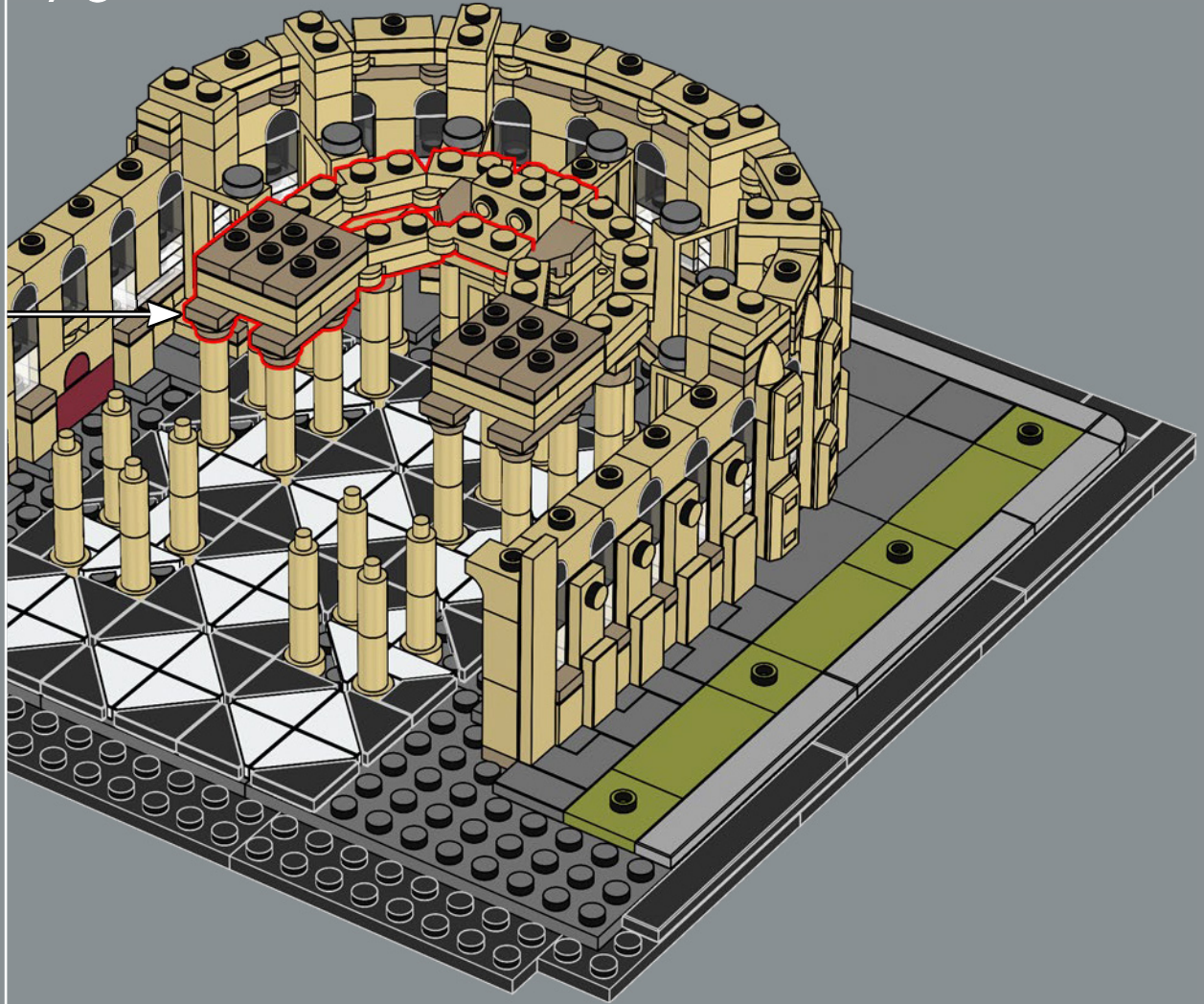

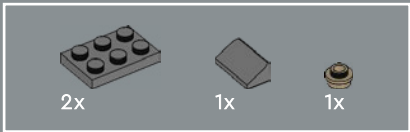

74

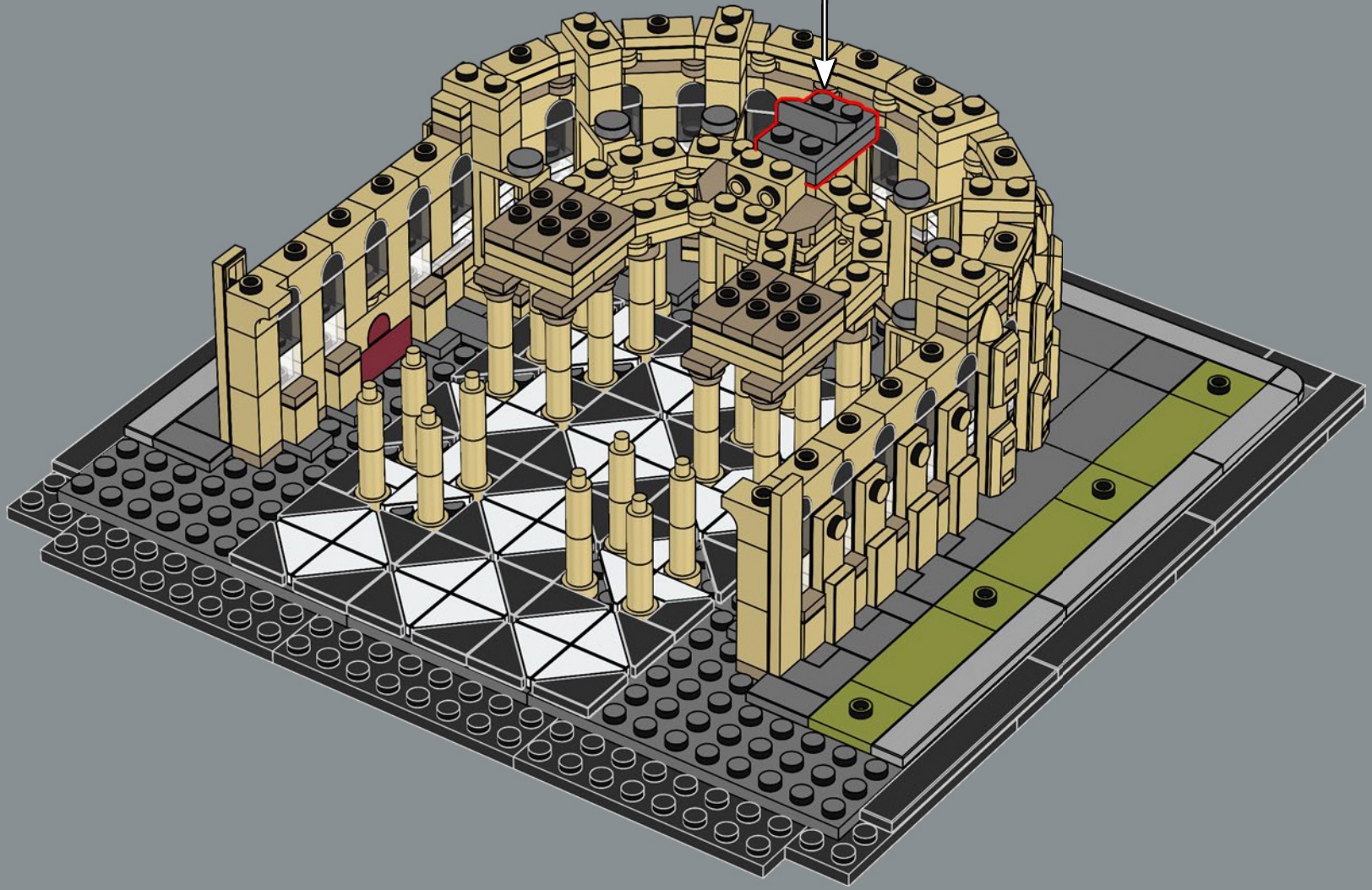
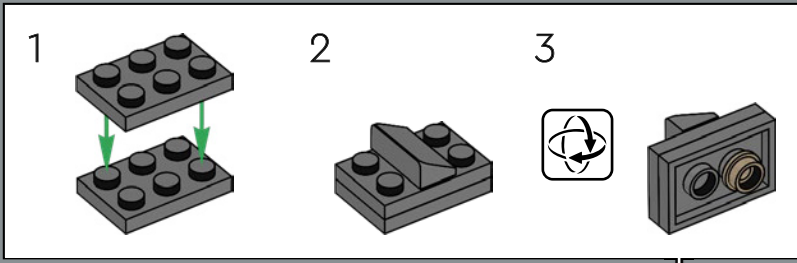

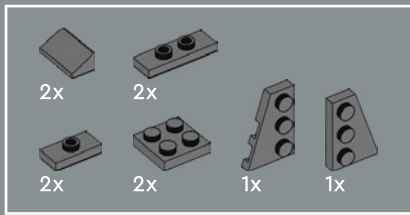

75

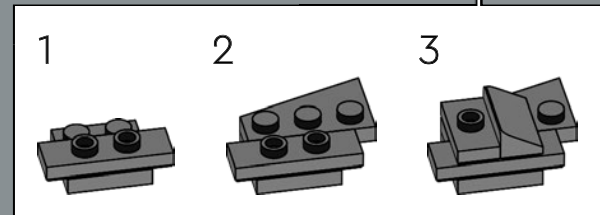
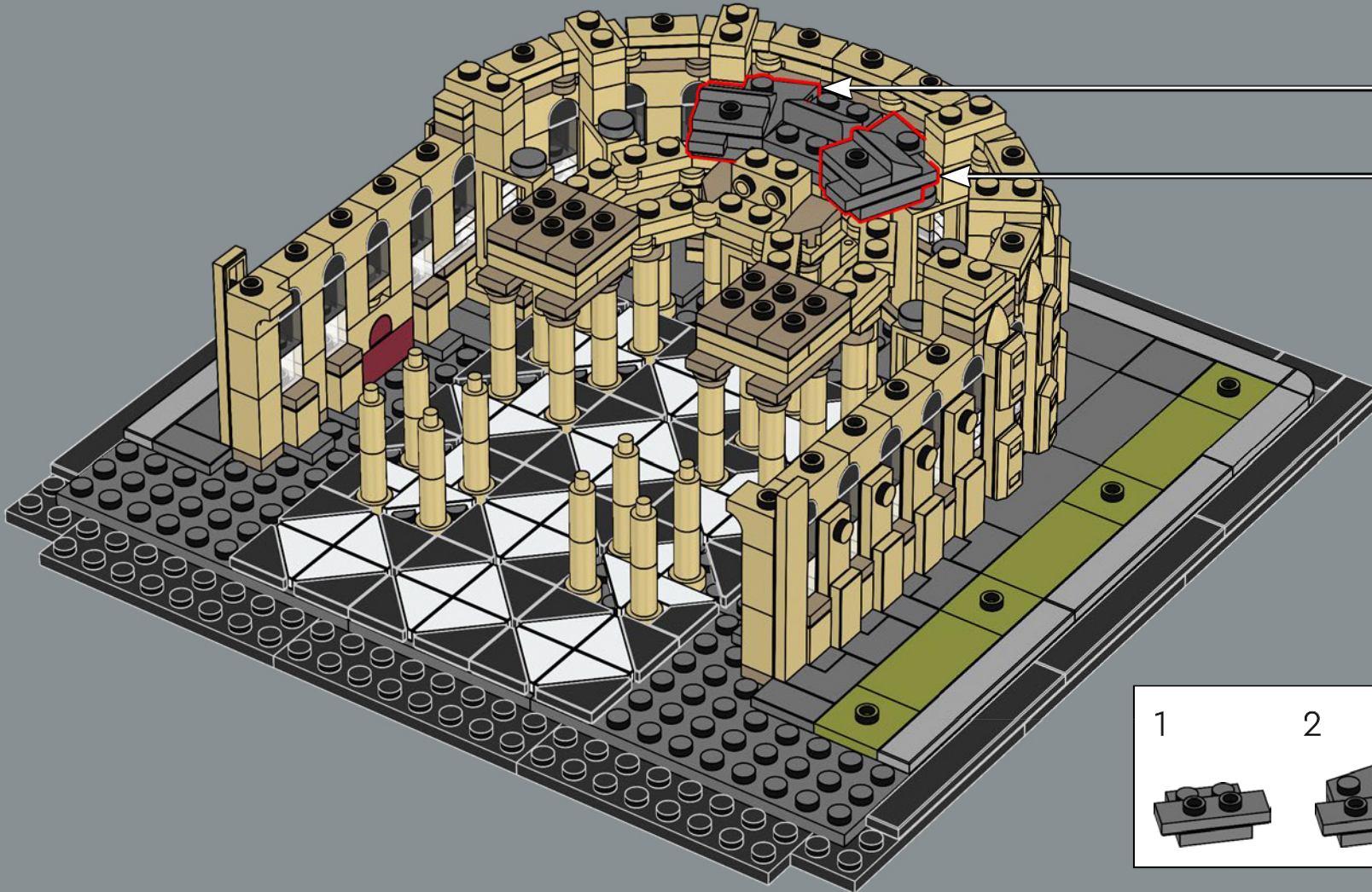
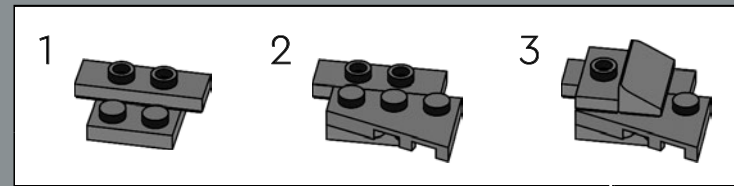

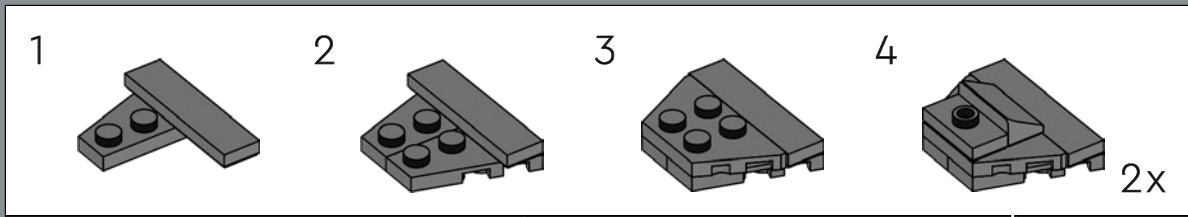
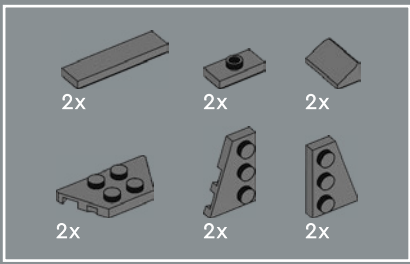

76

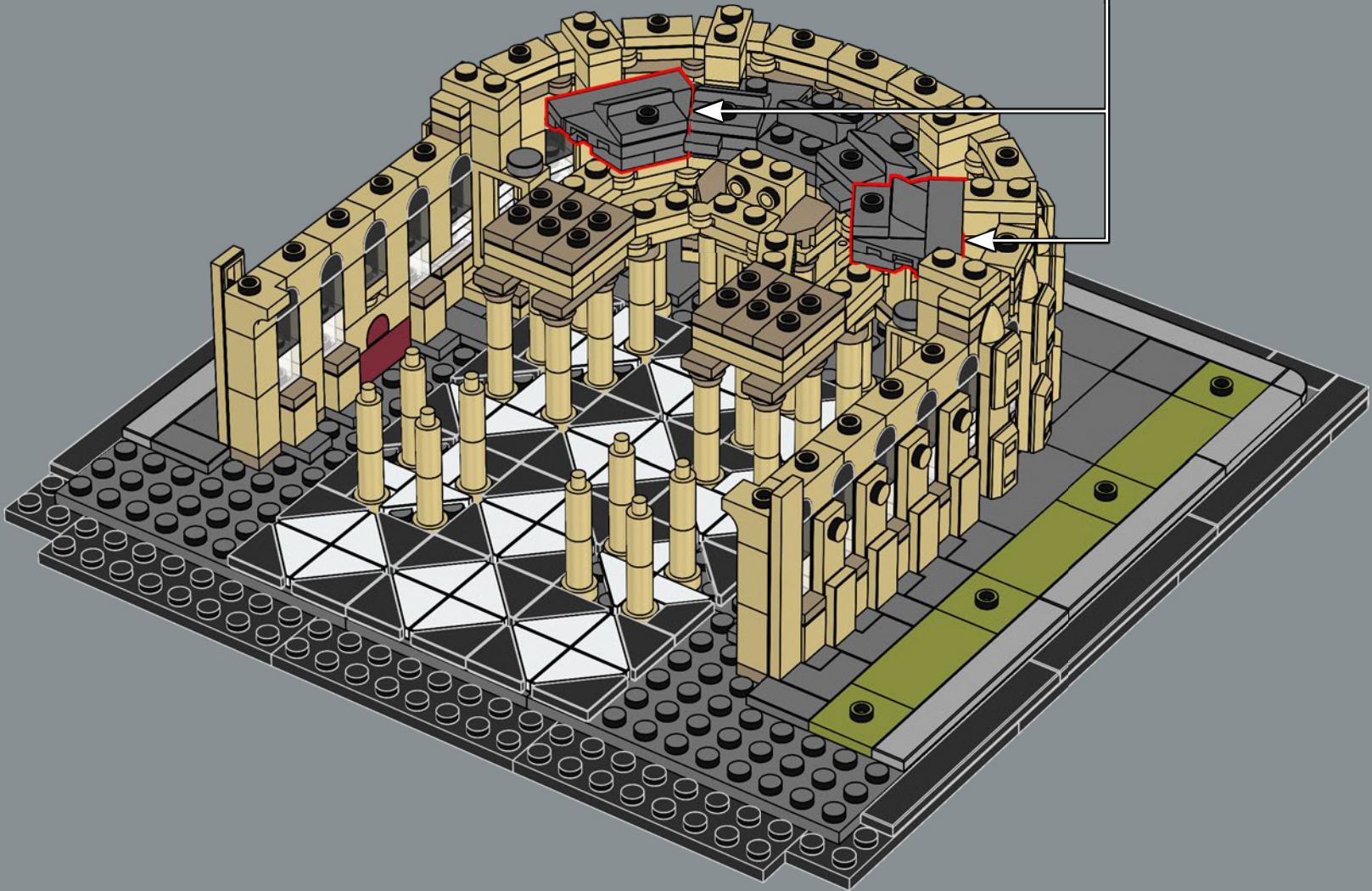

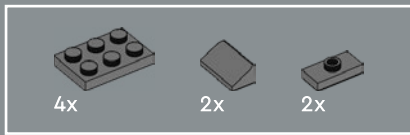

77

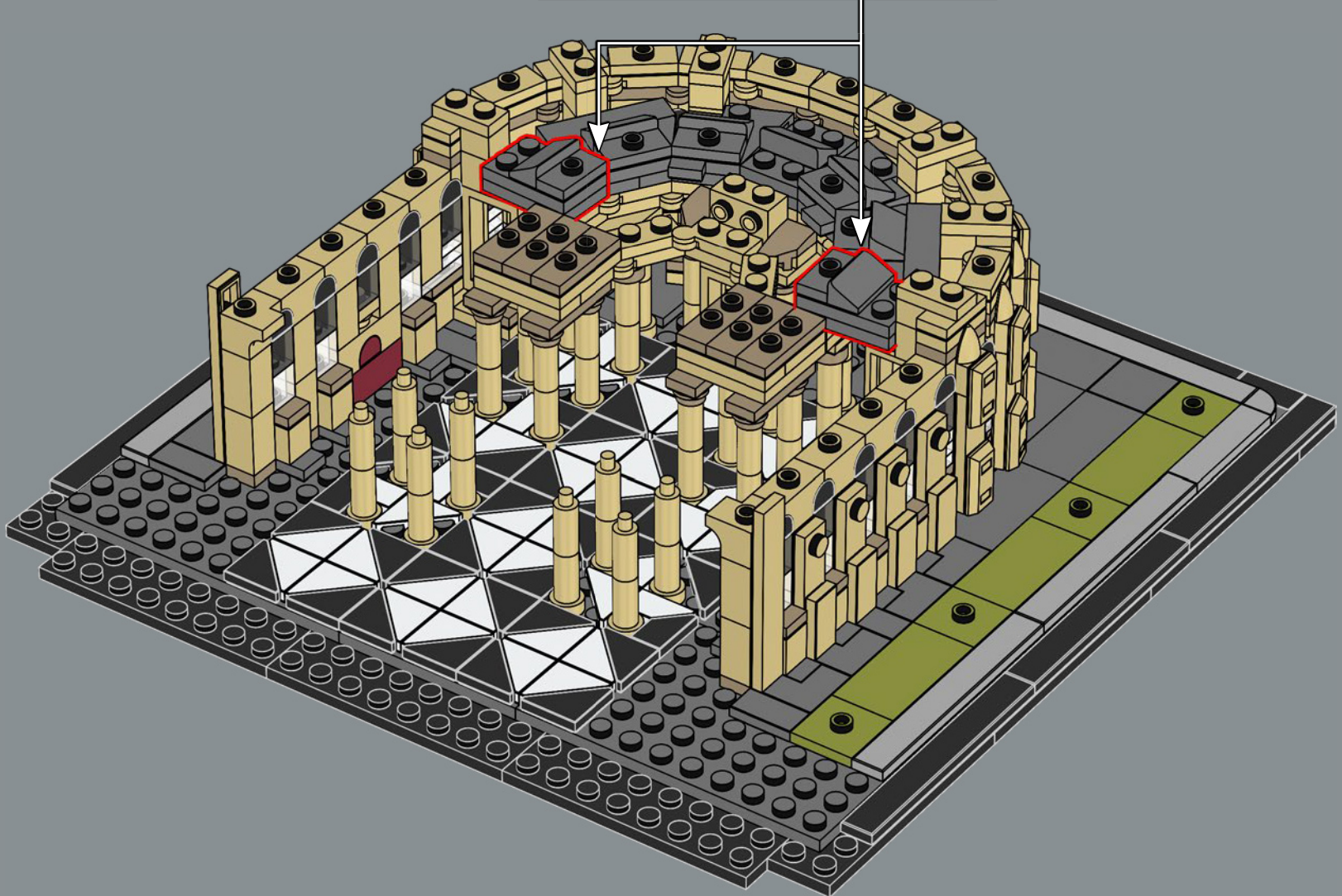
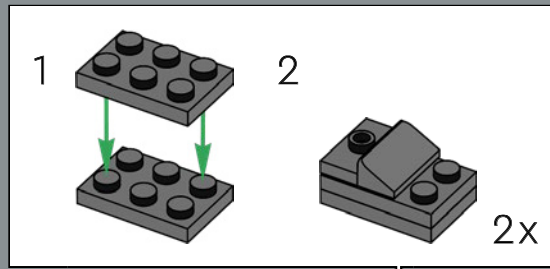



78

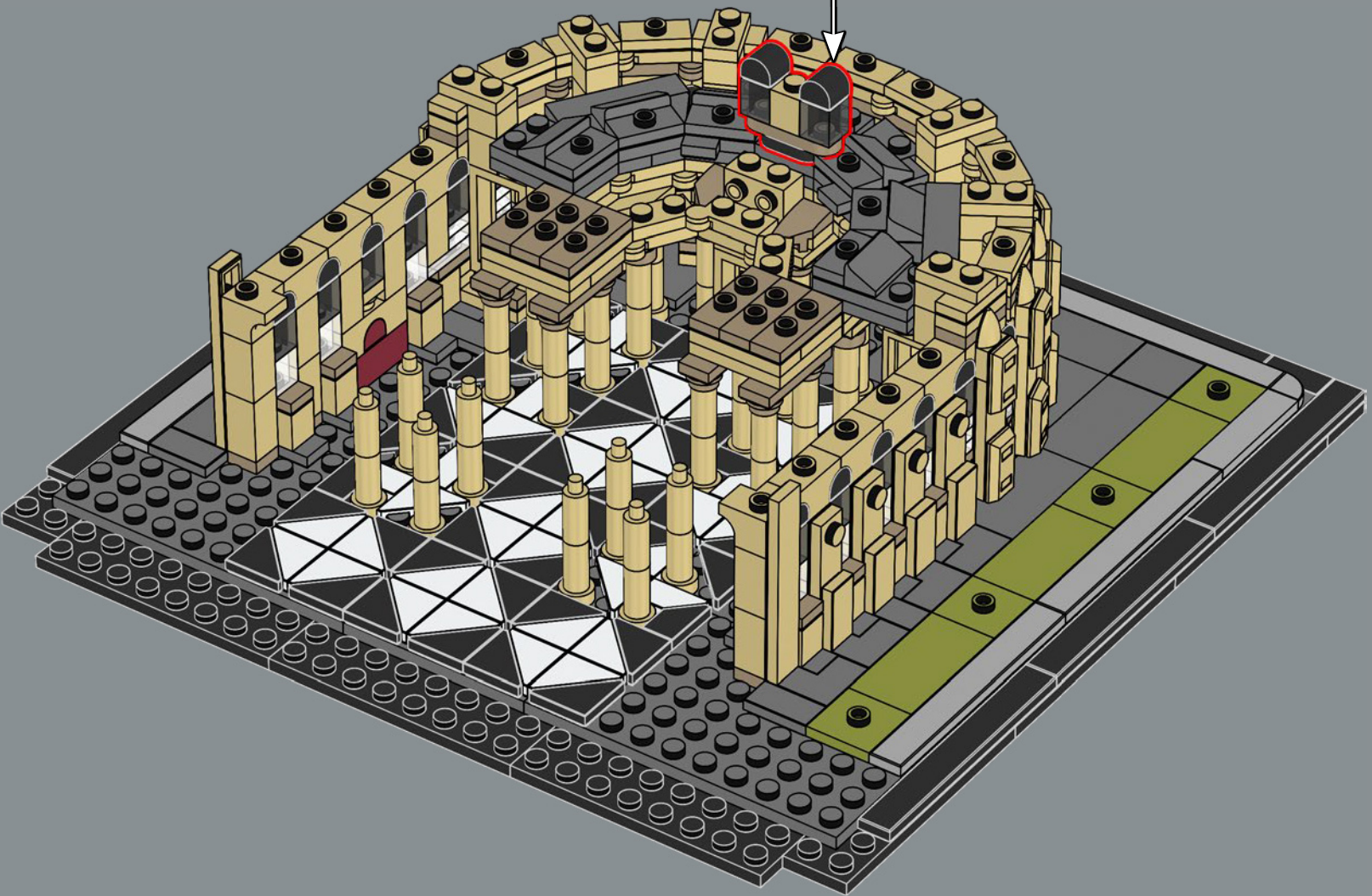
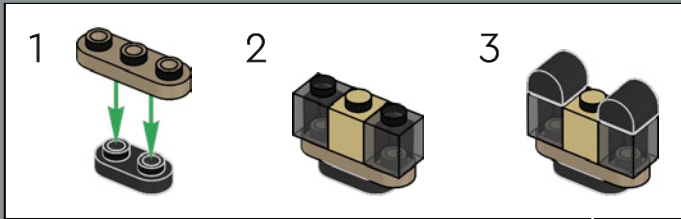



79

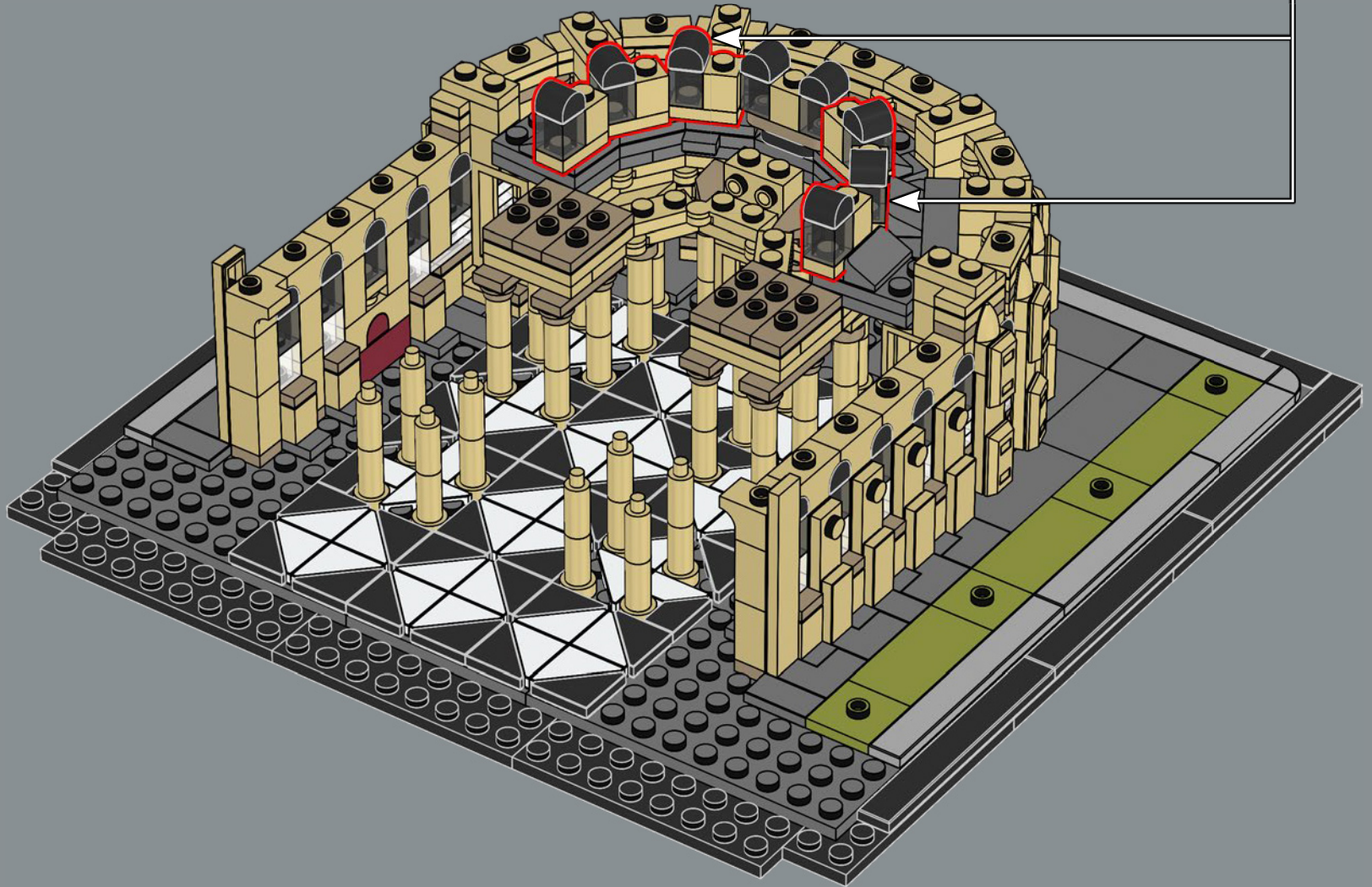
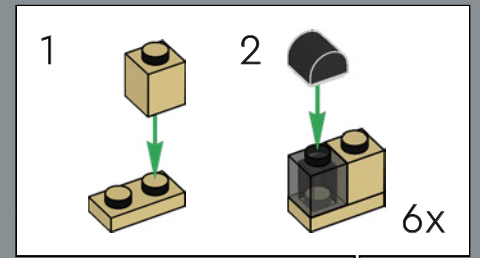



7x

80

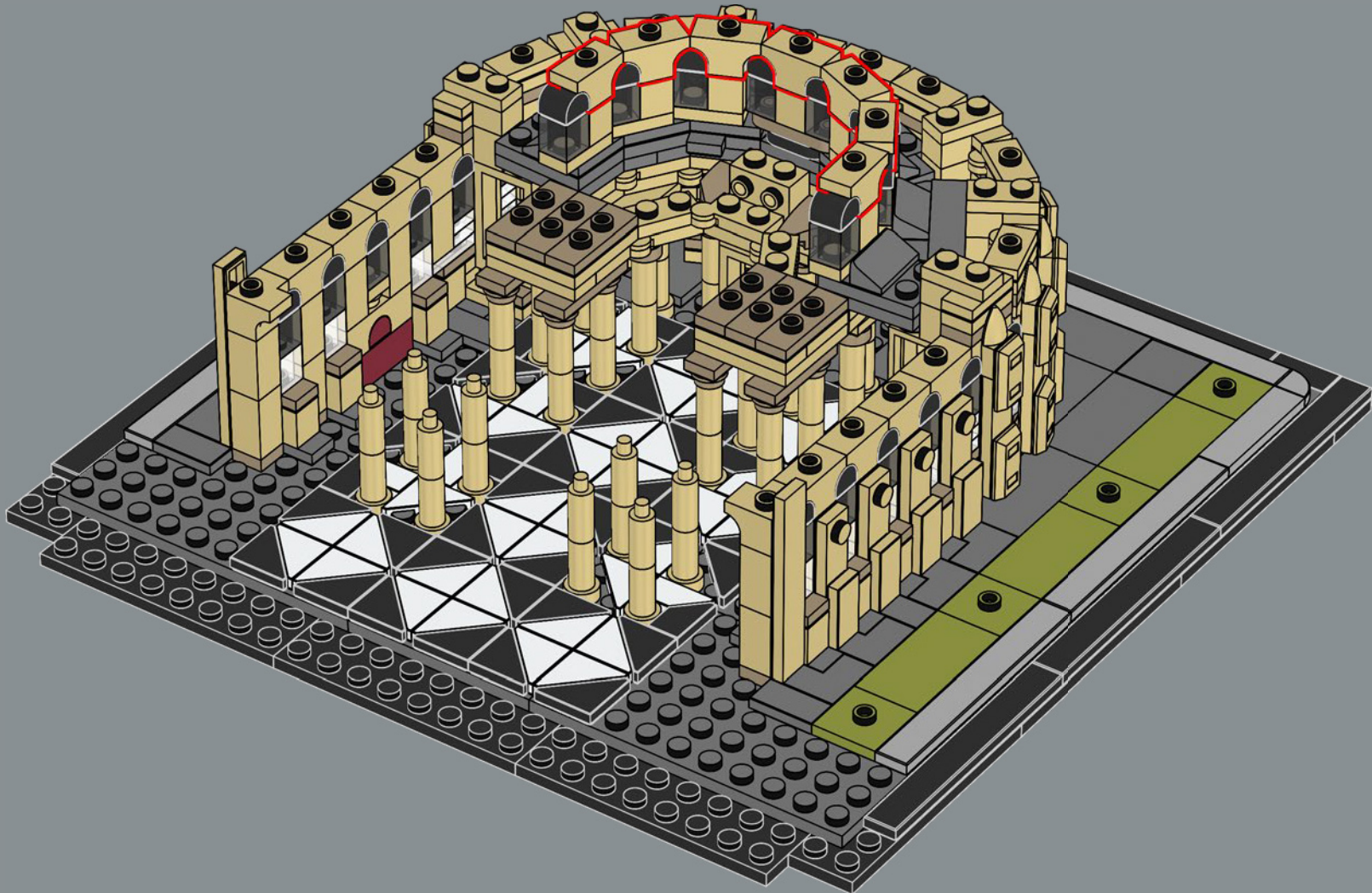

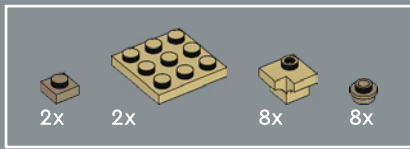

81

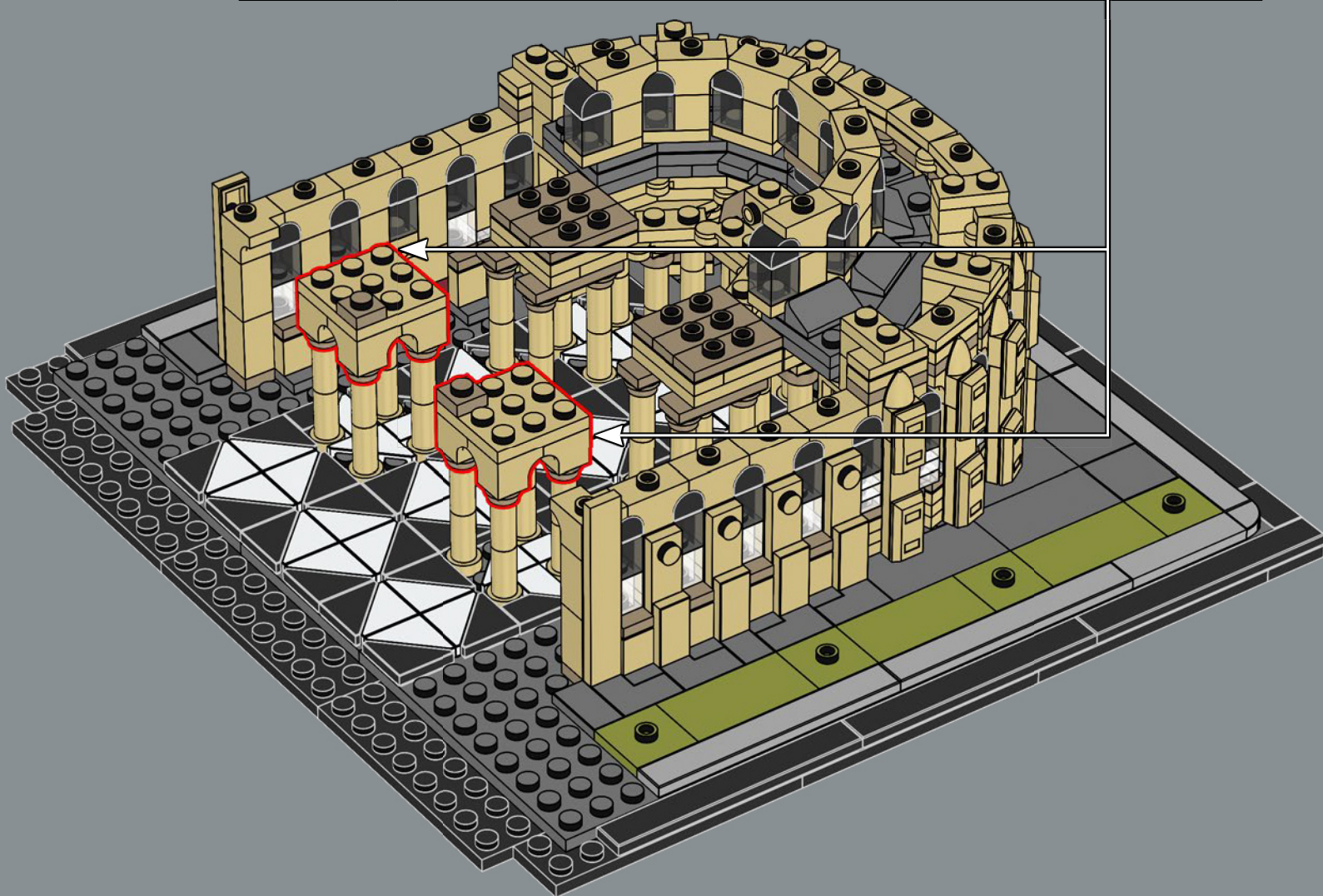
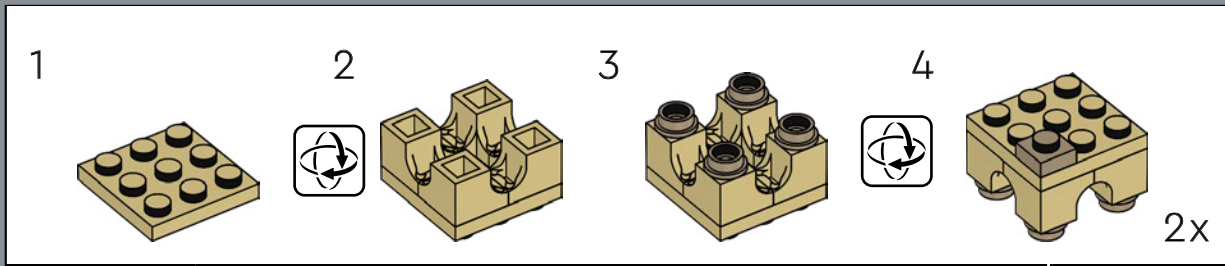

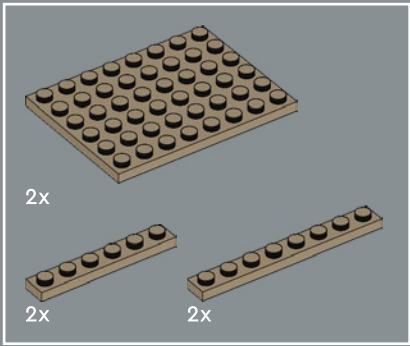

82

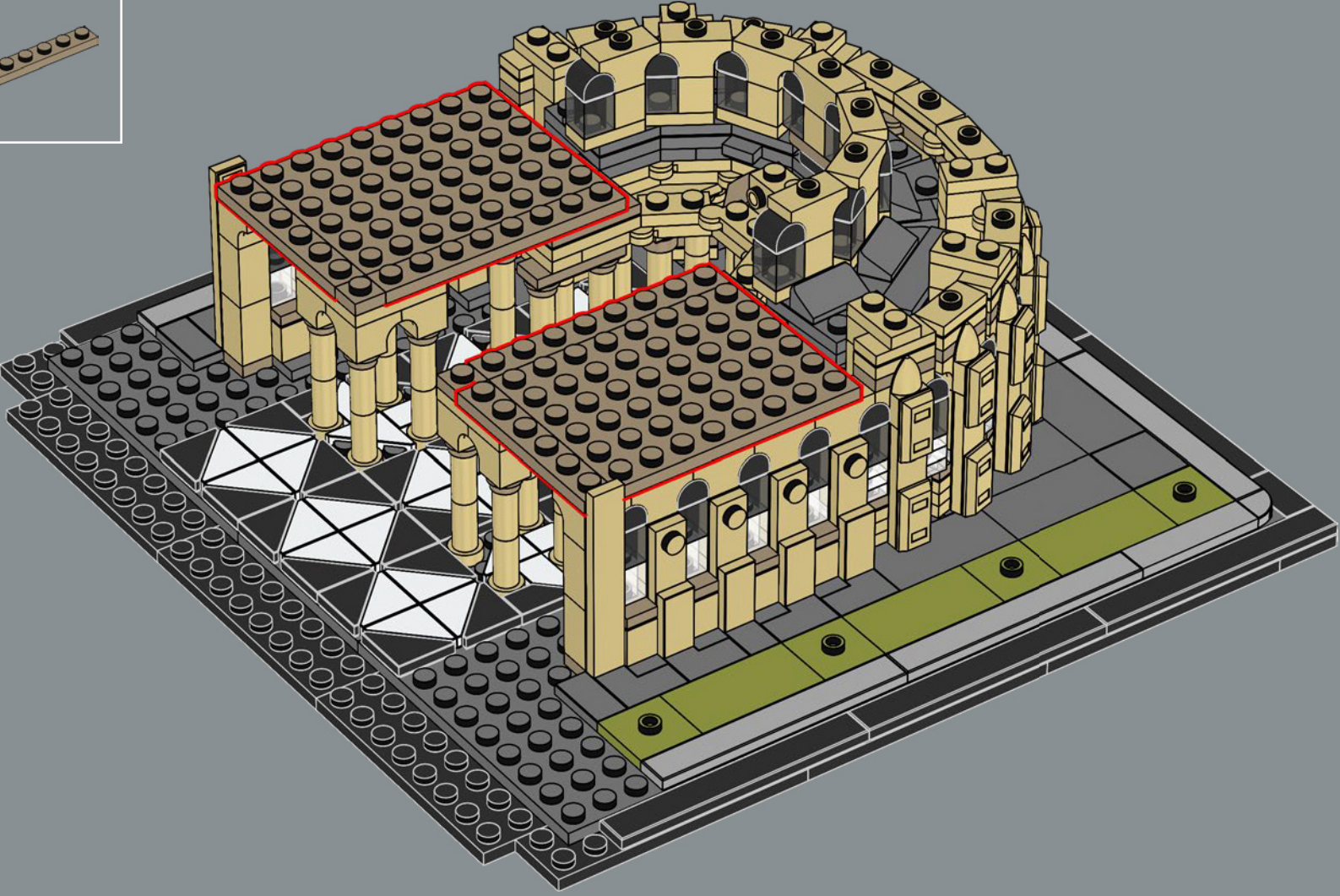



83

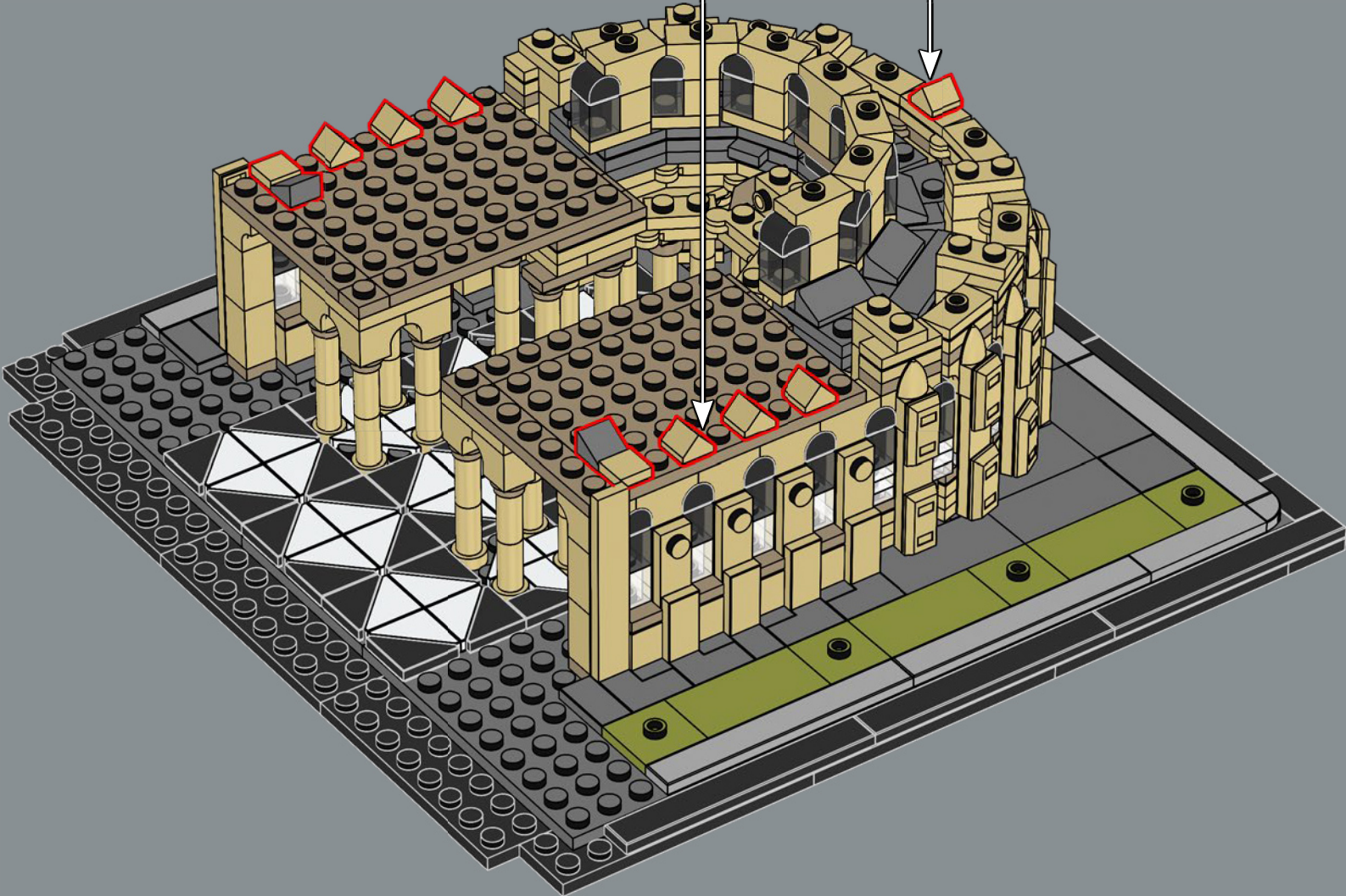

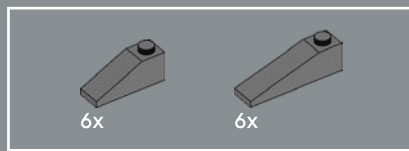

84

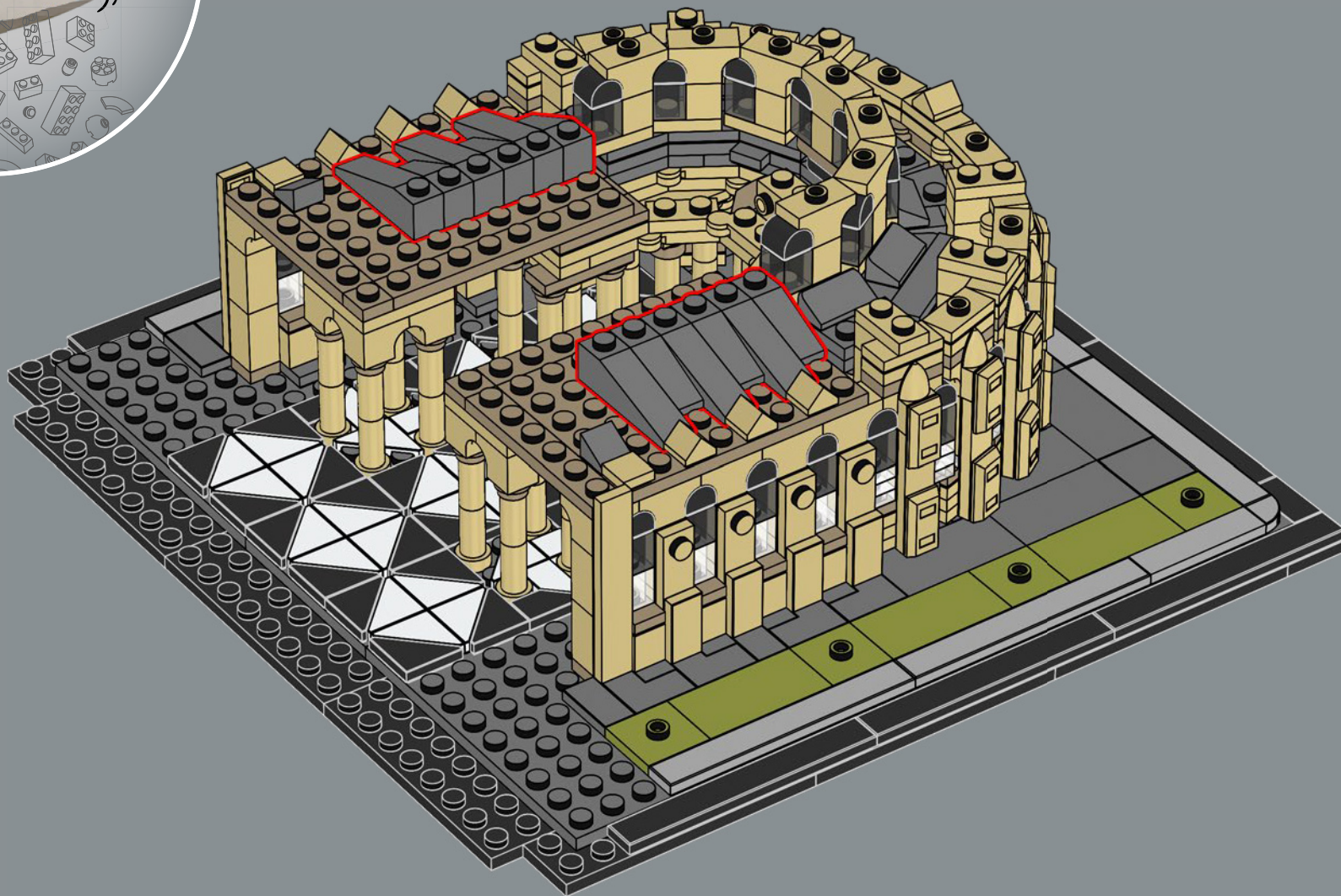

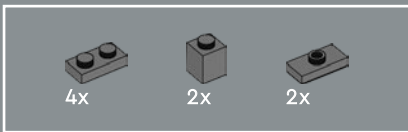

85

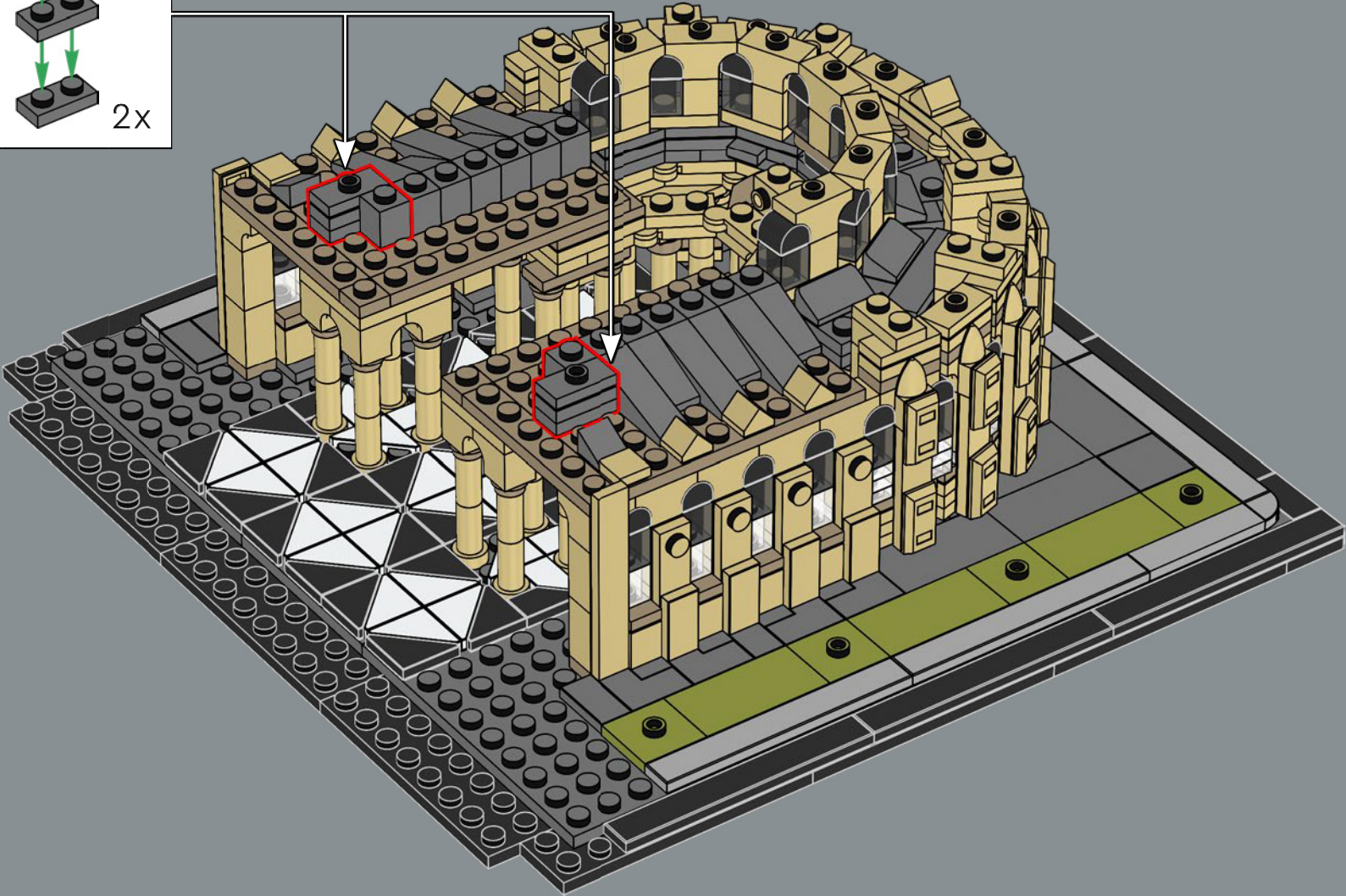
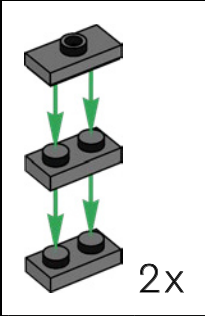



12x

86

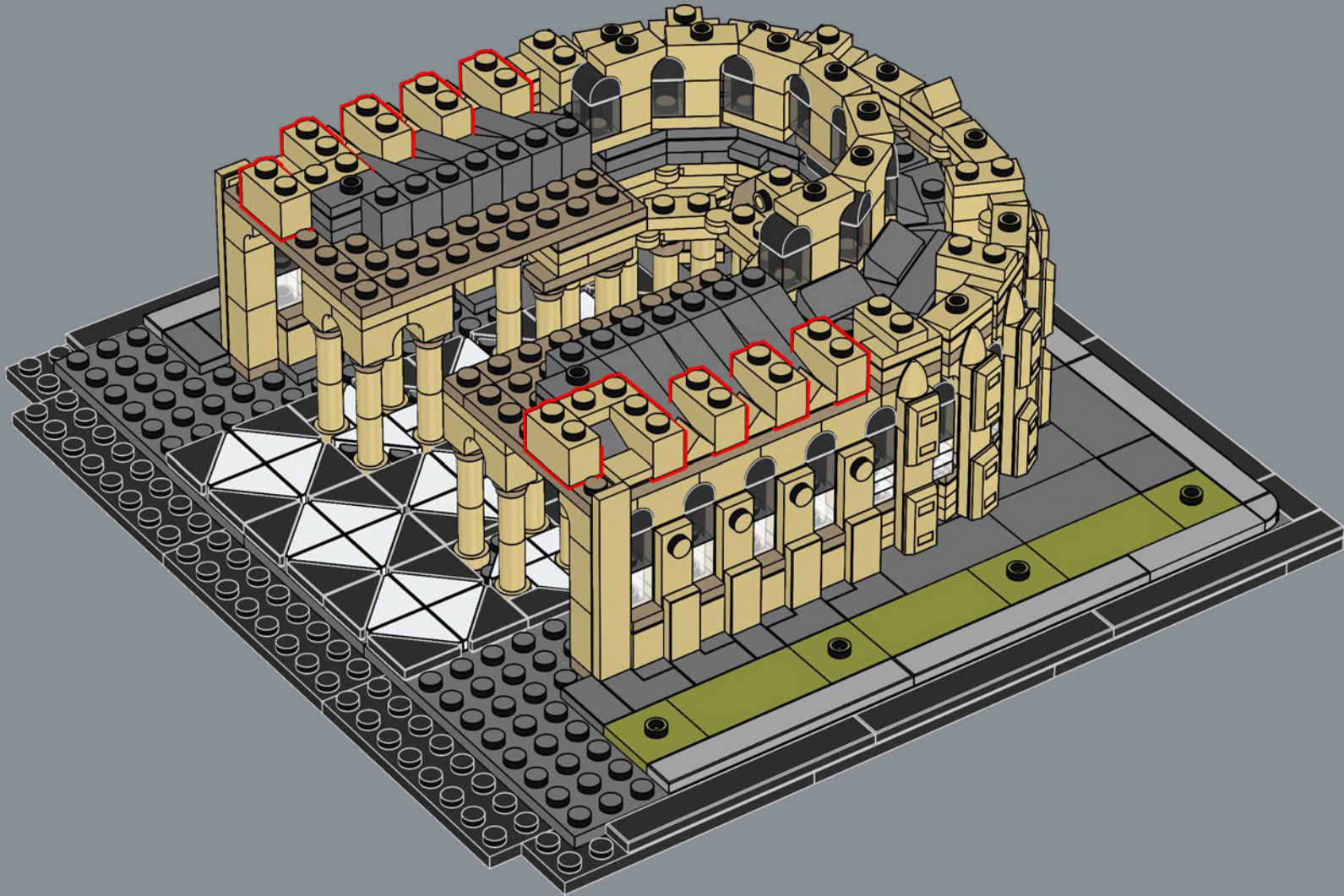

- 
8x
- 
8x
- 
2x
- 
14x
- 
8x

87

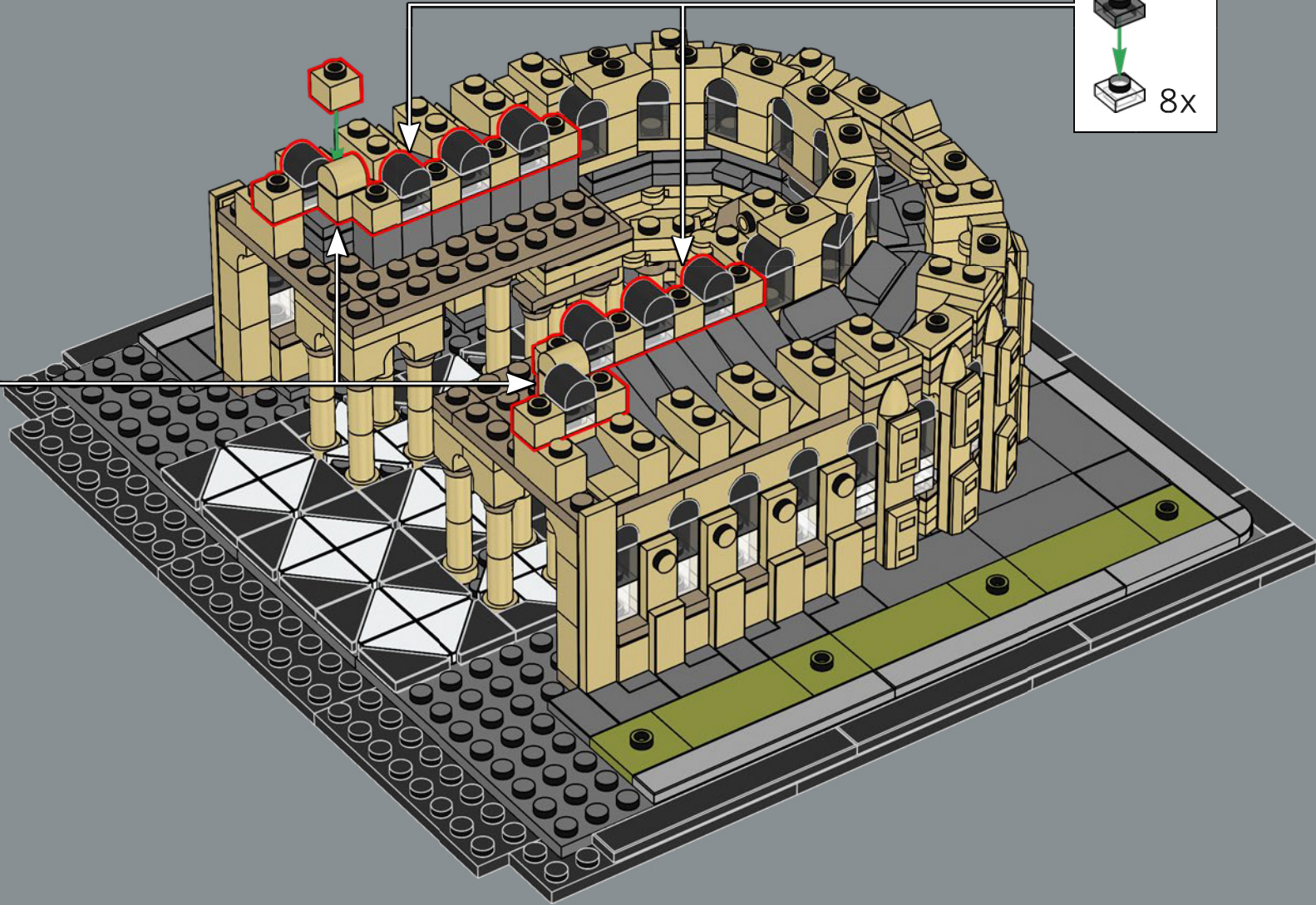
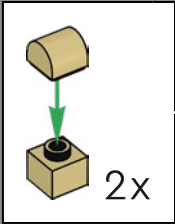
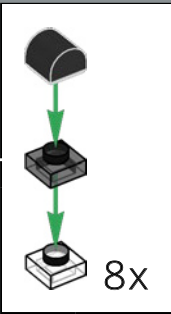

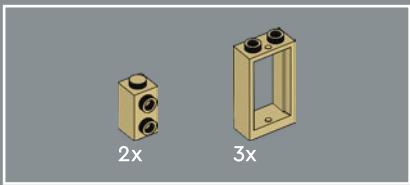

88

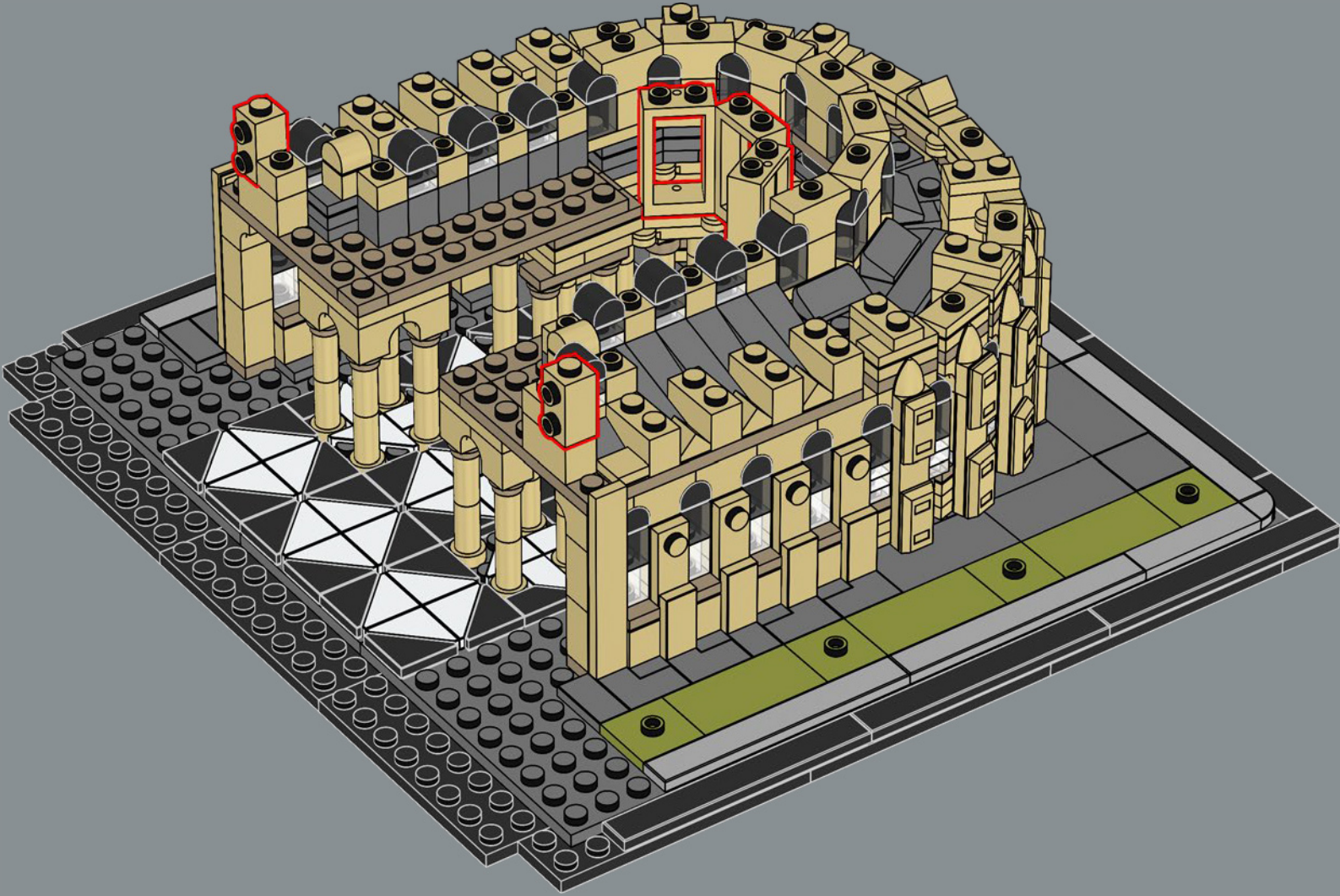

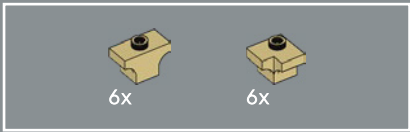

89

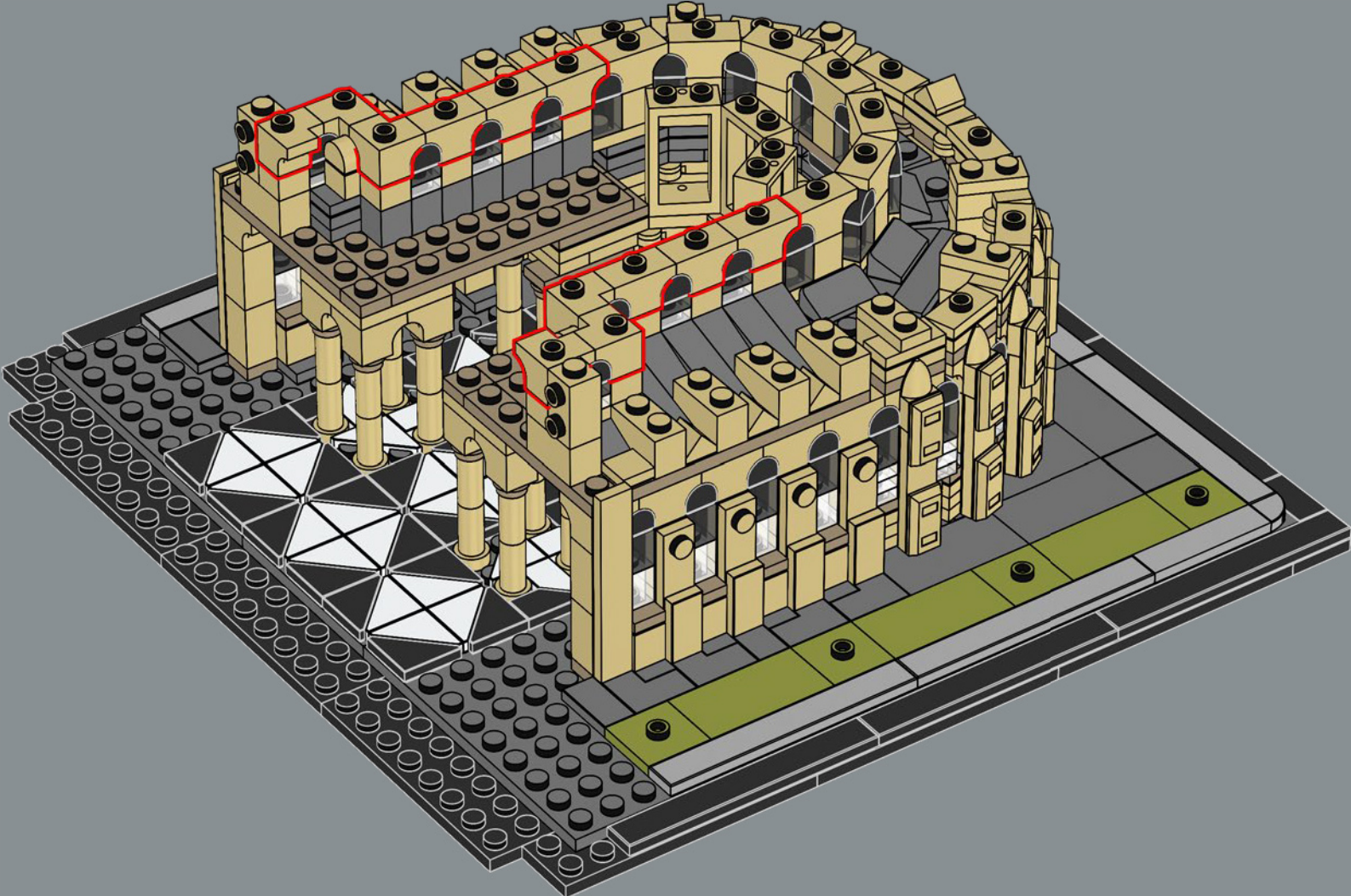

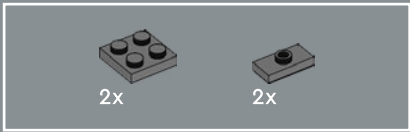

90

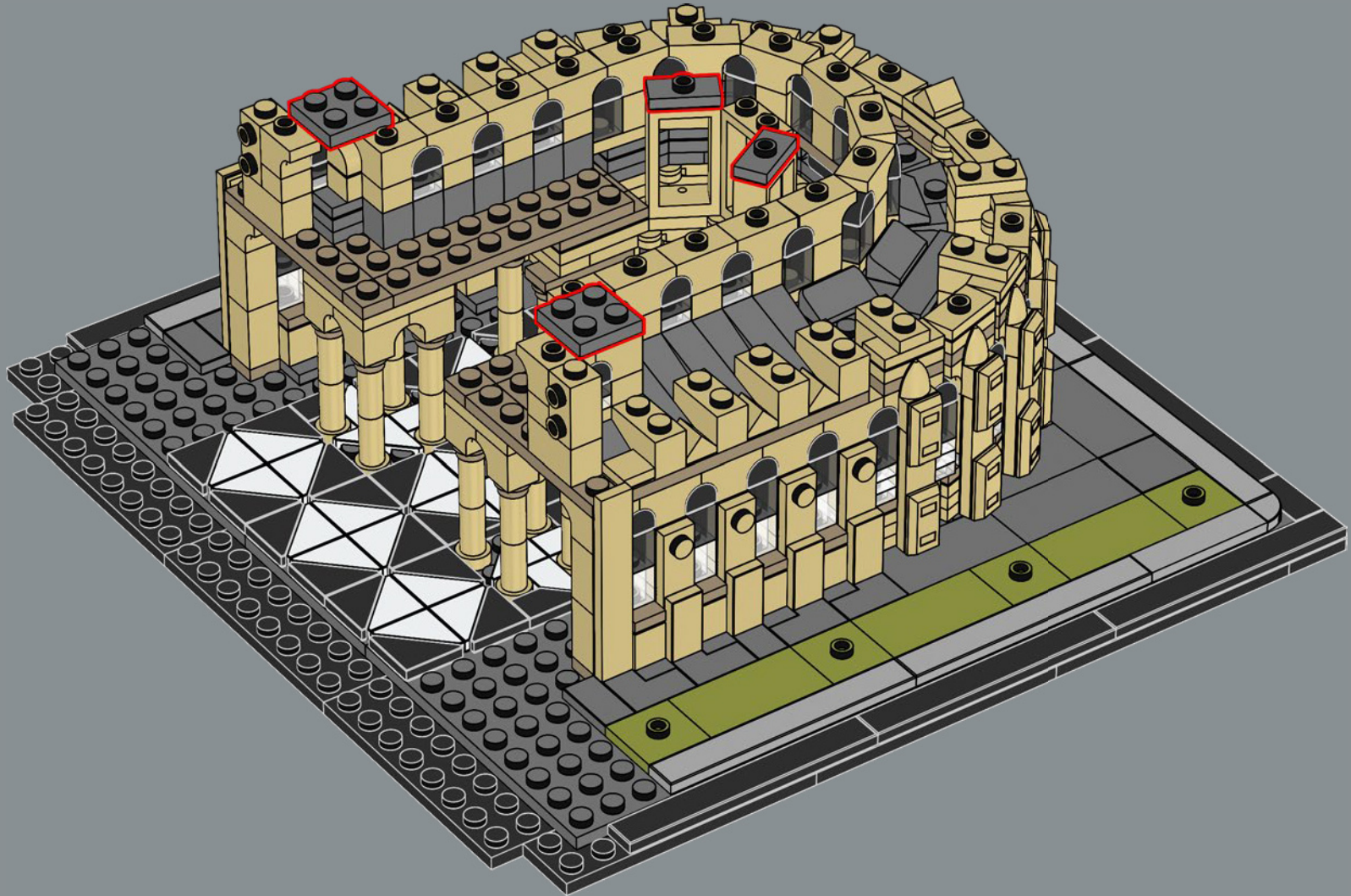

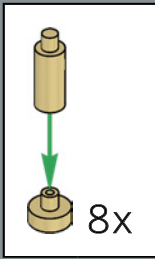

91

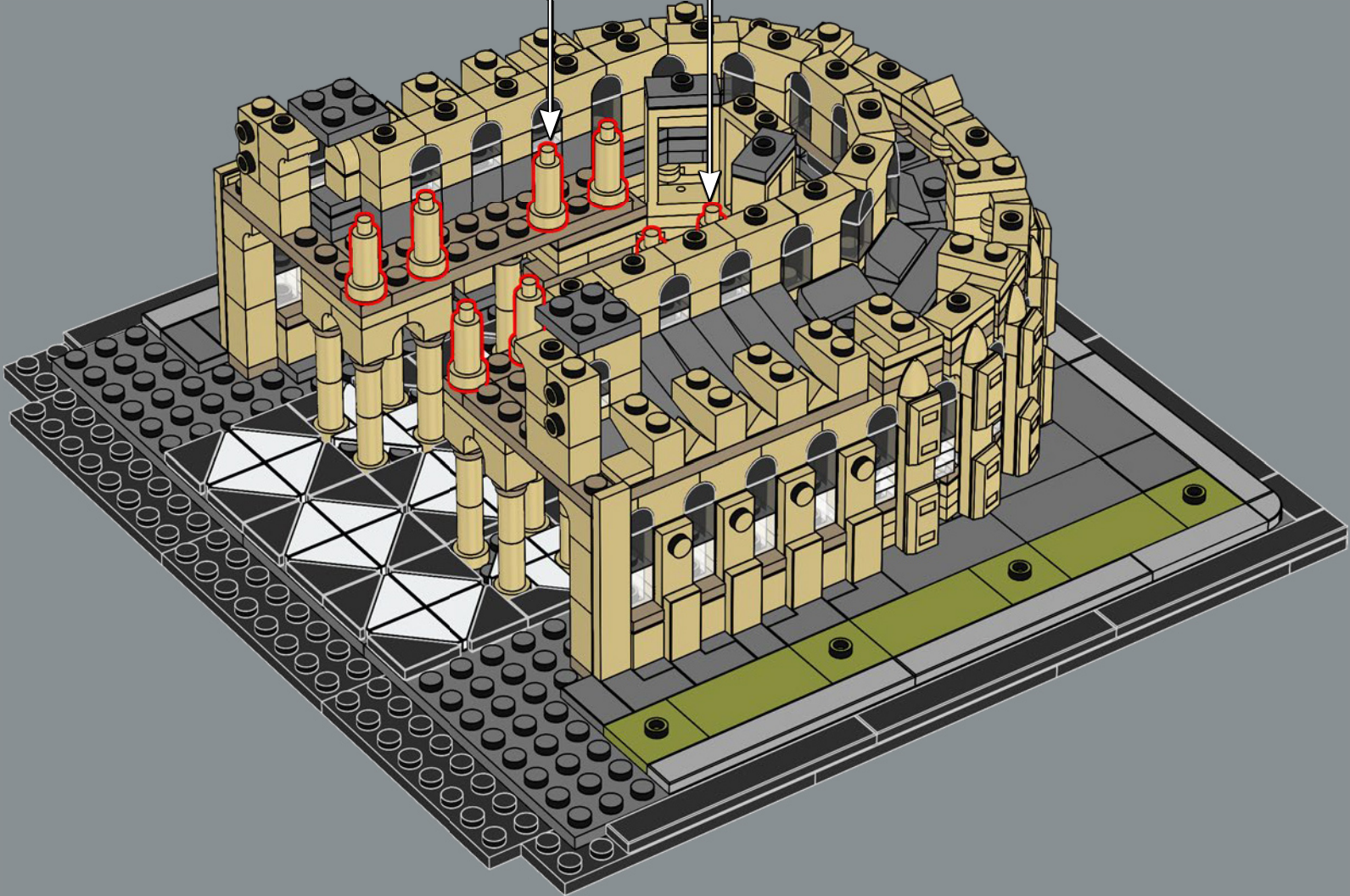

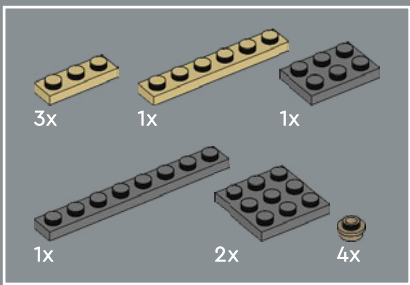

92

1

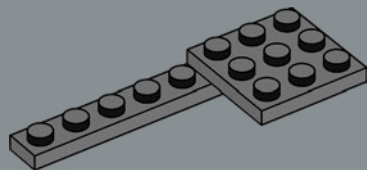

2

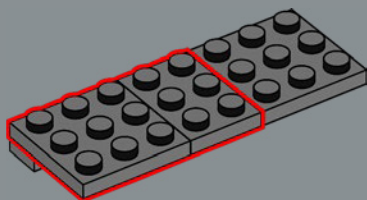

3

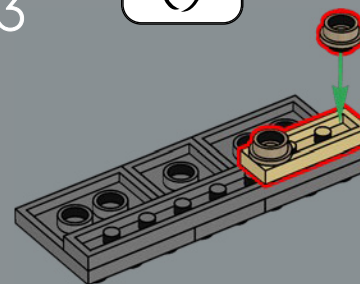

1

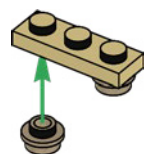

2

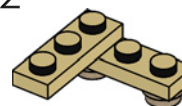

3

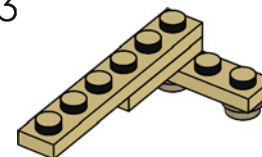

4

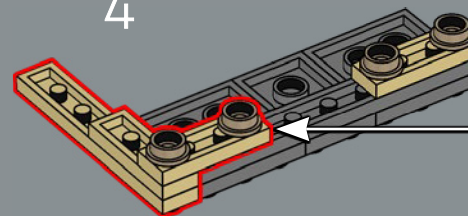

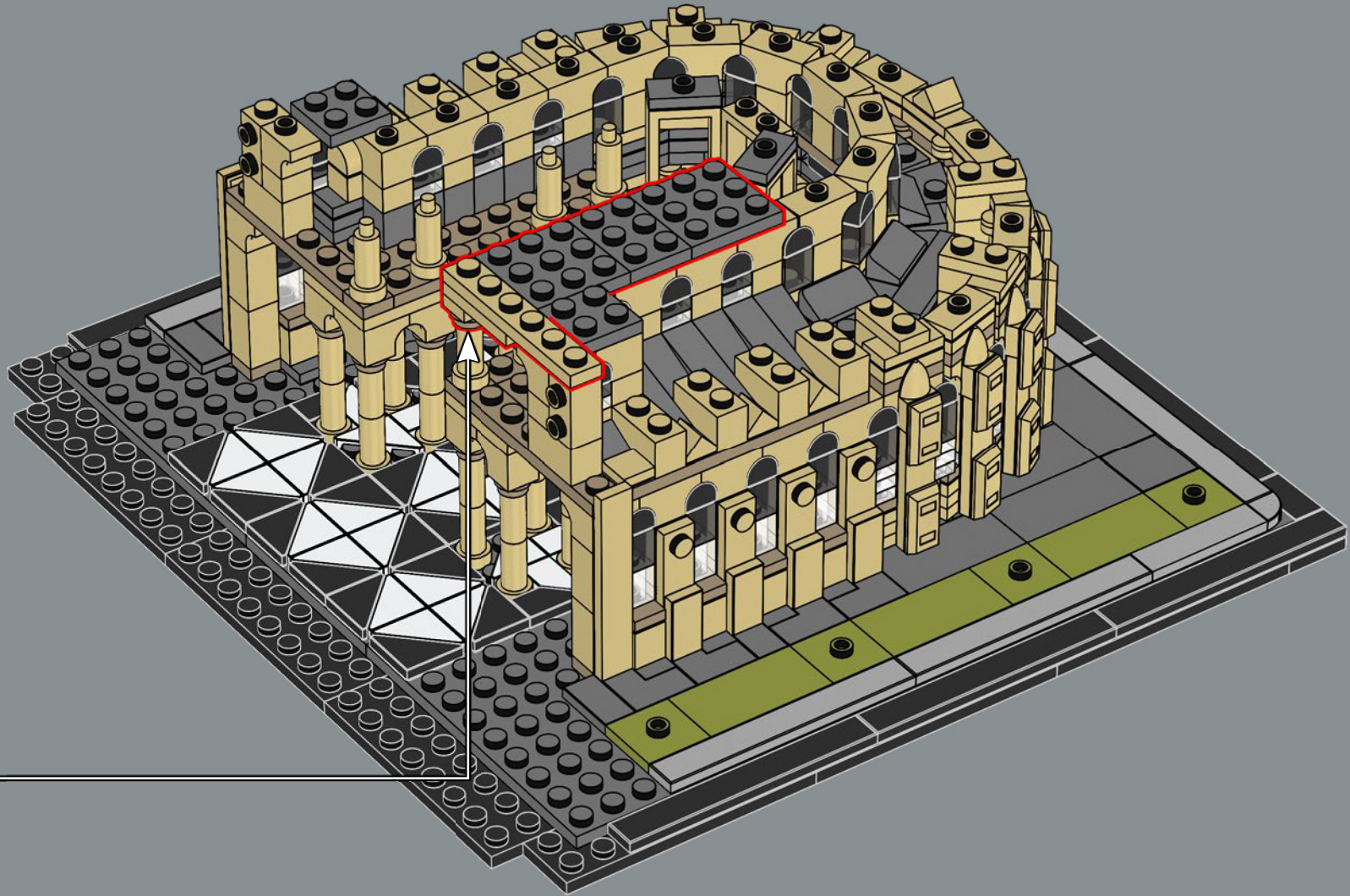

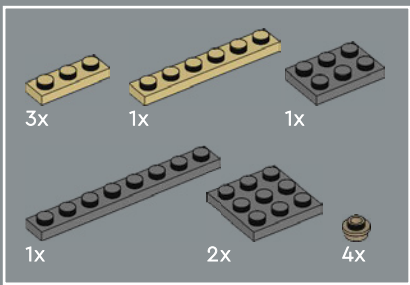

93

1

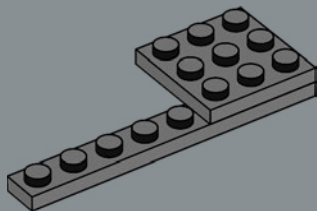

2

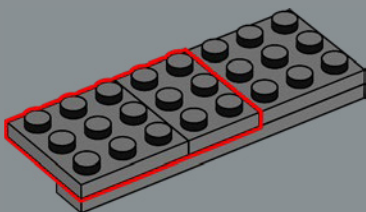

3

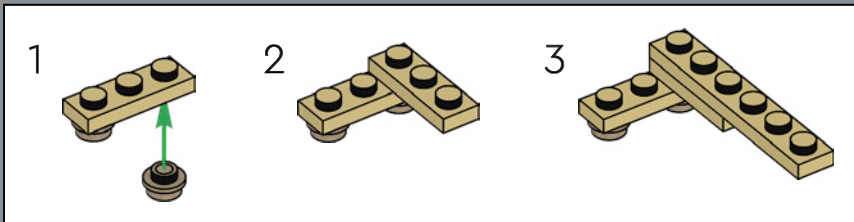
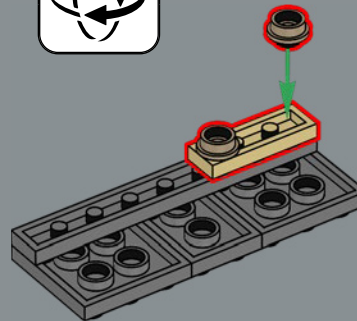

4

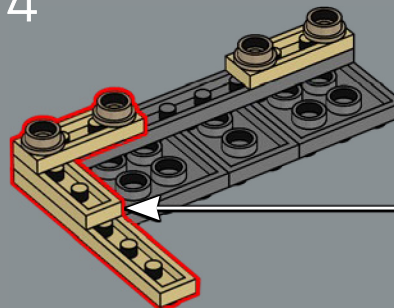

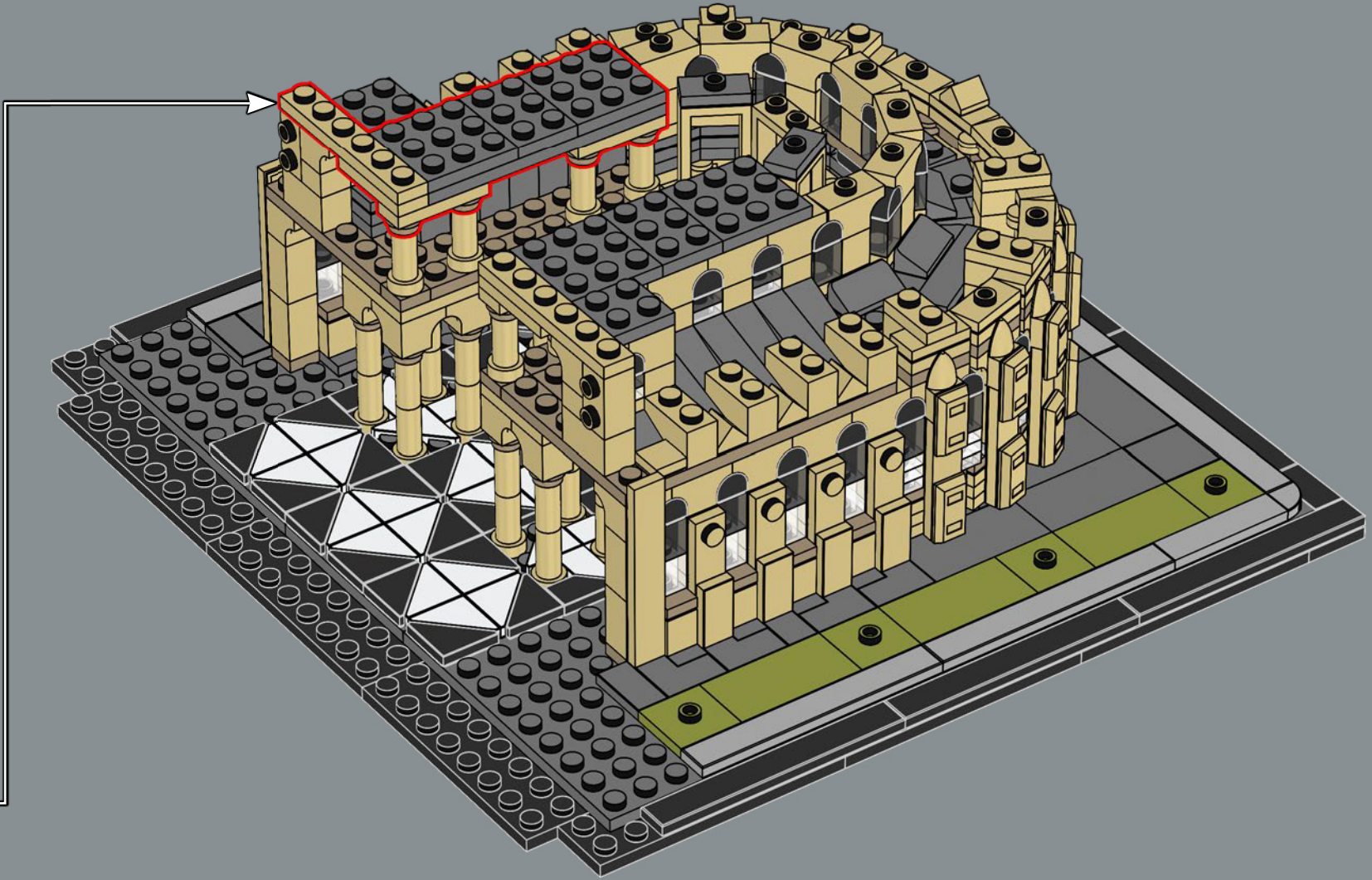



6x

94

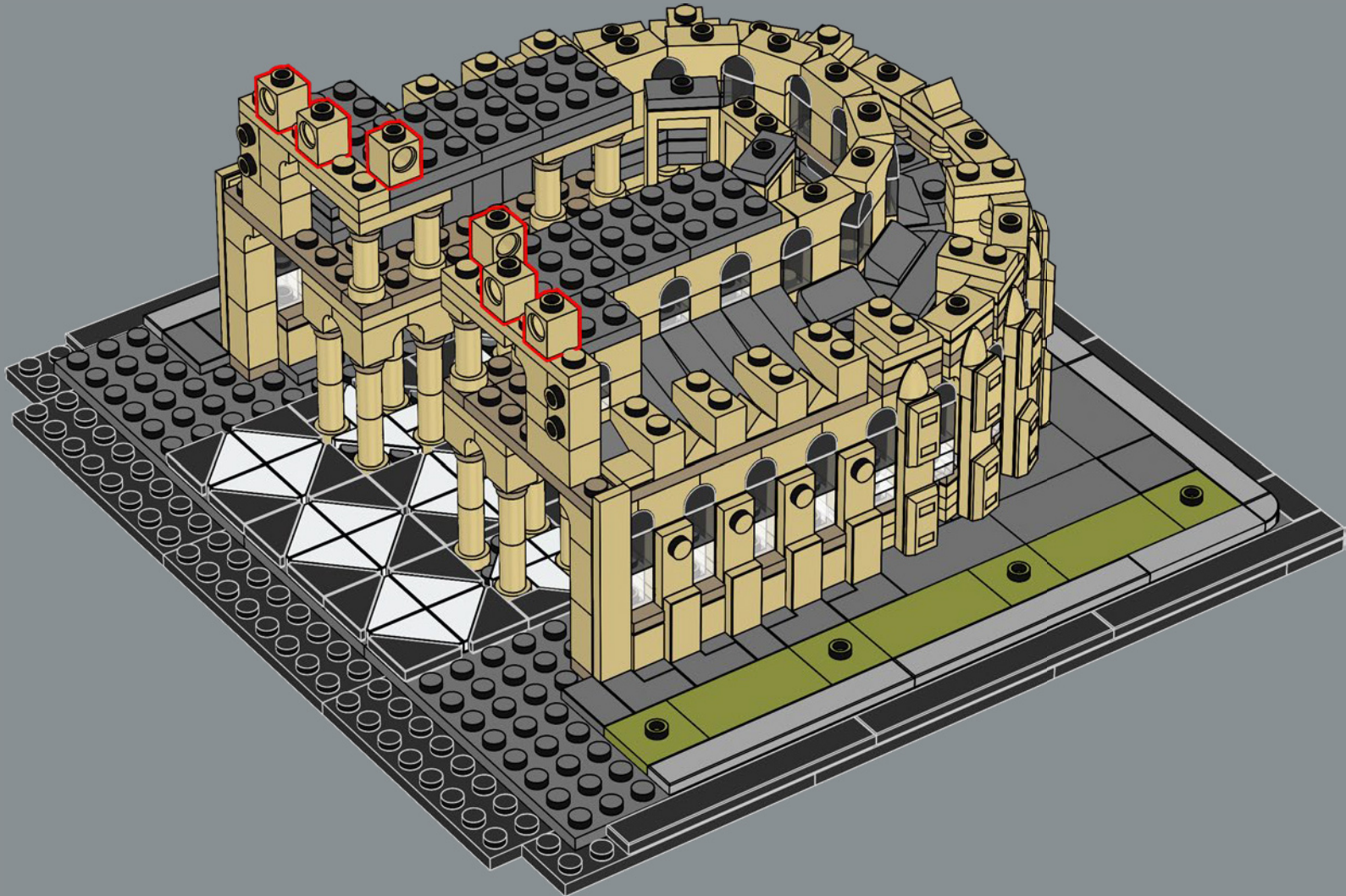



95

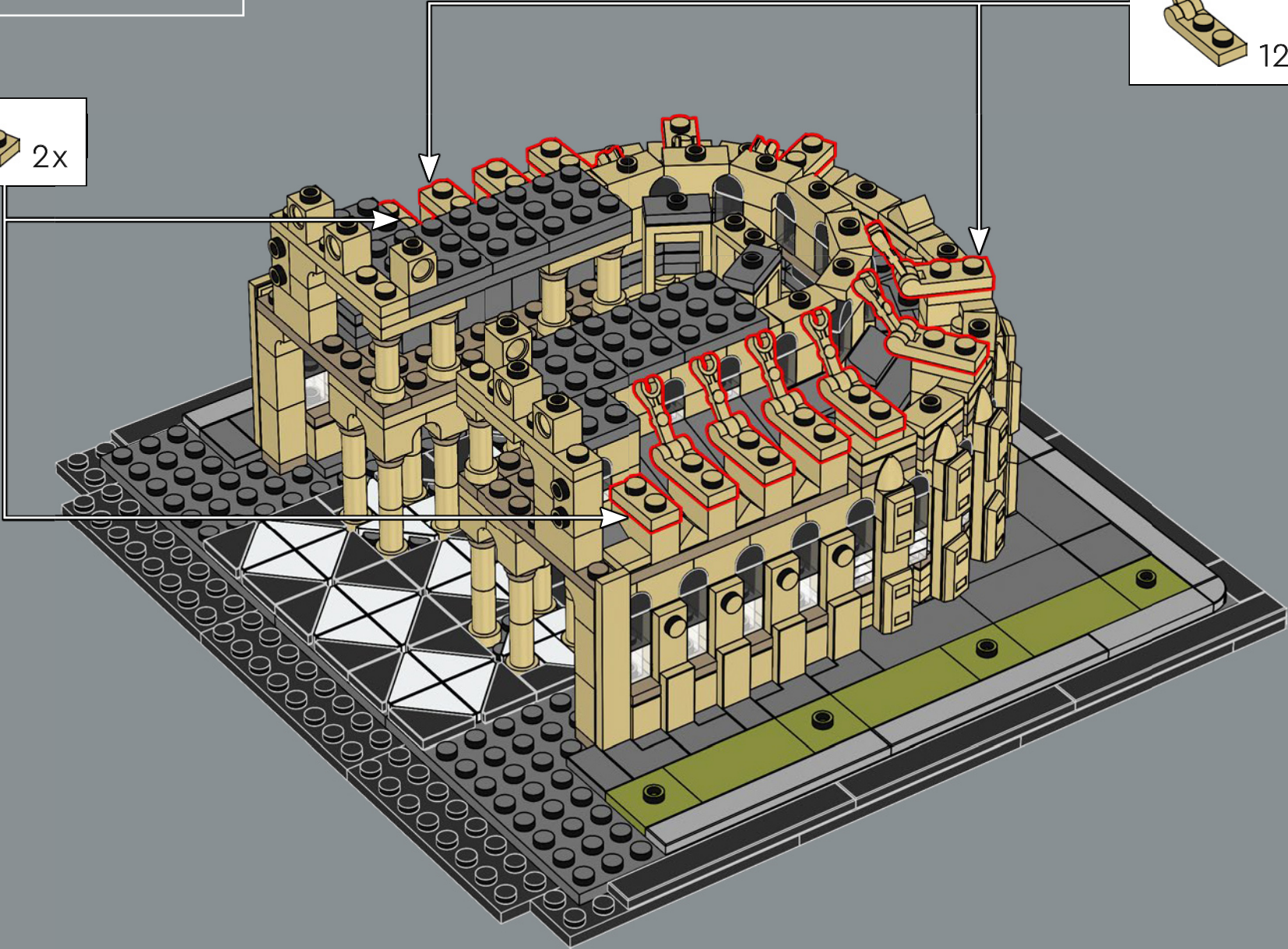
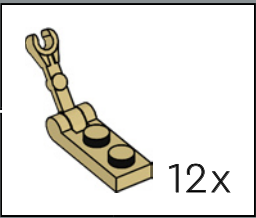
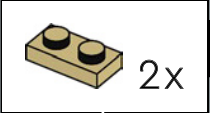

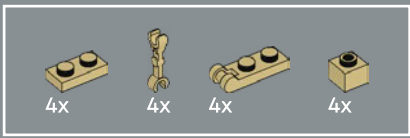

96

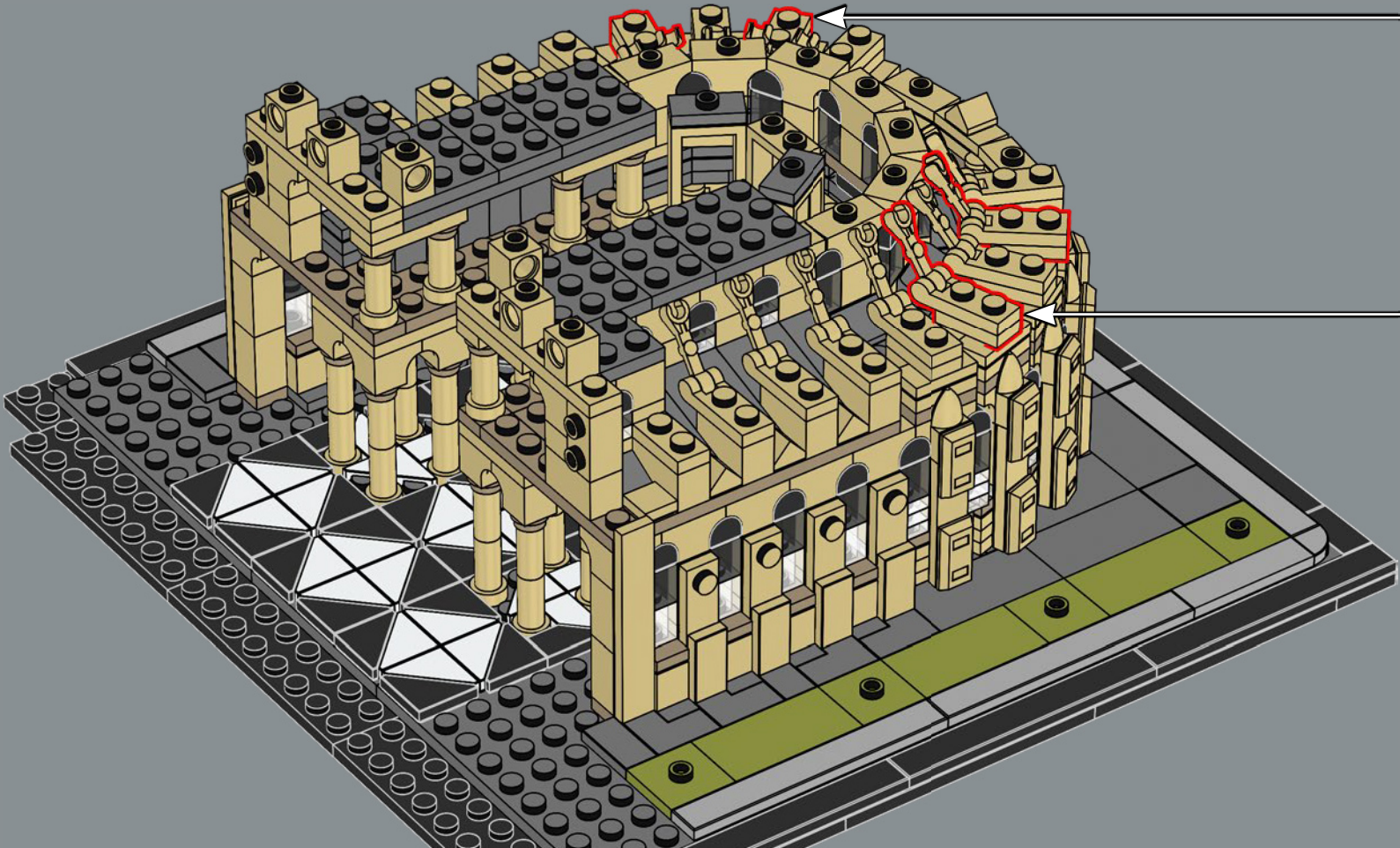
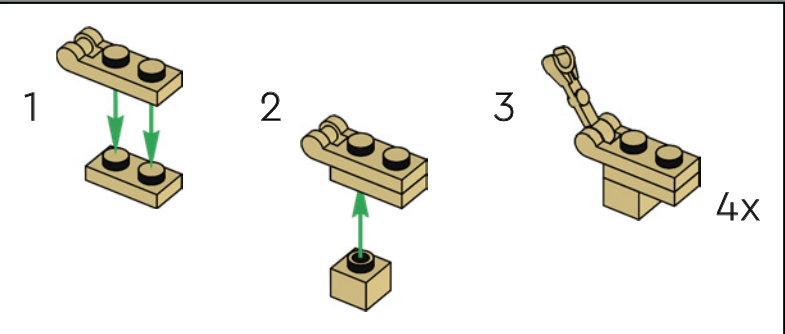

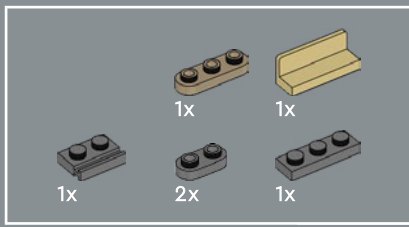

97

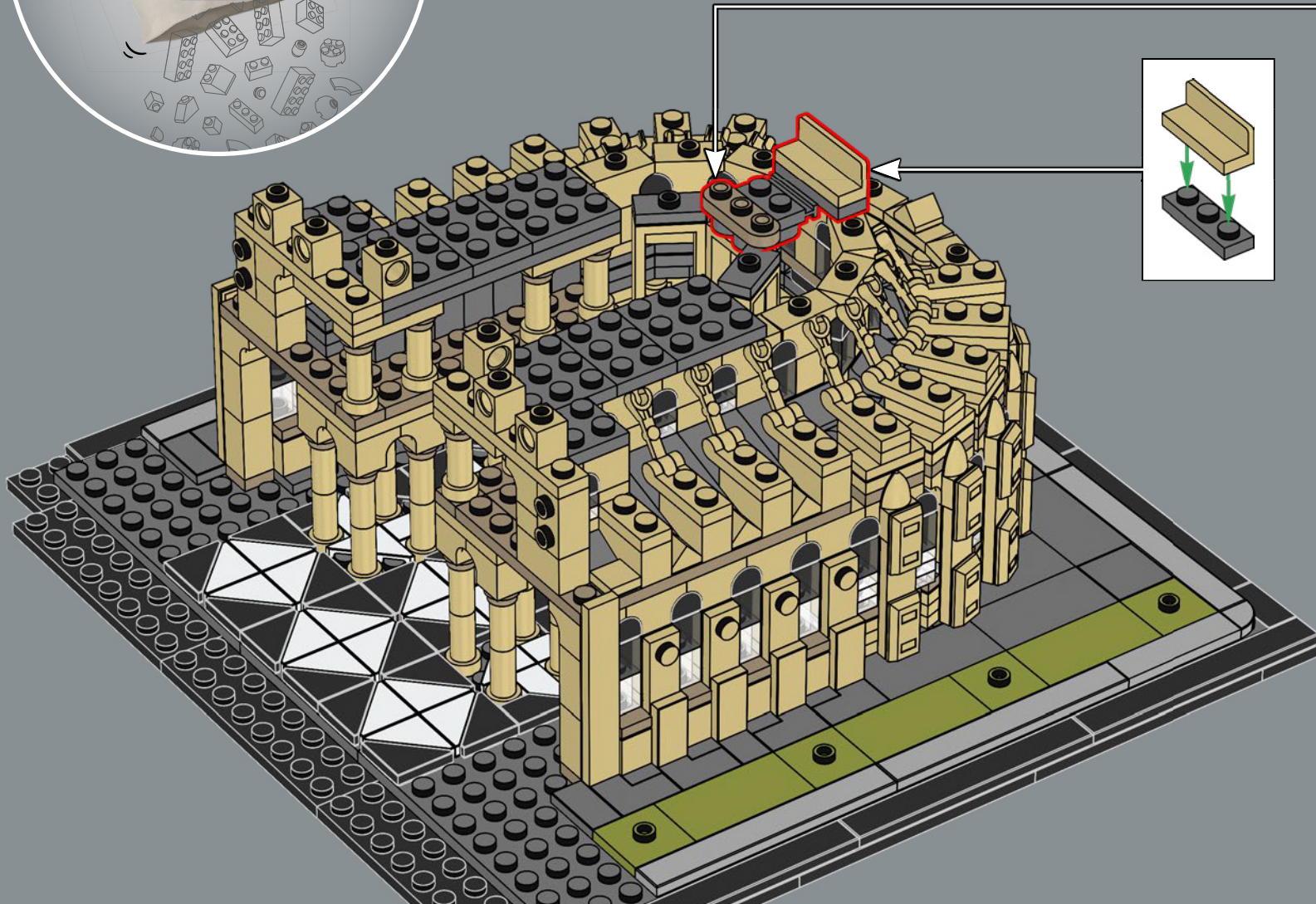
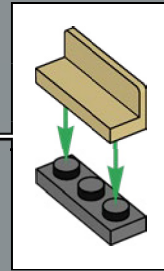
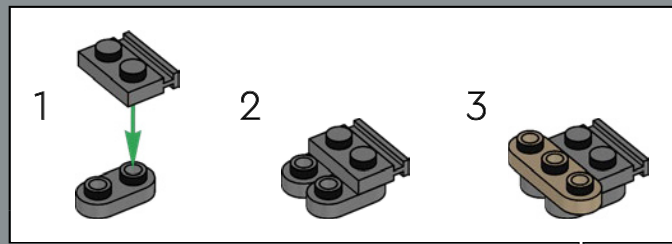



98

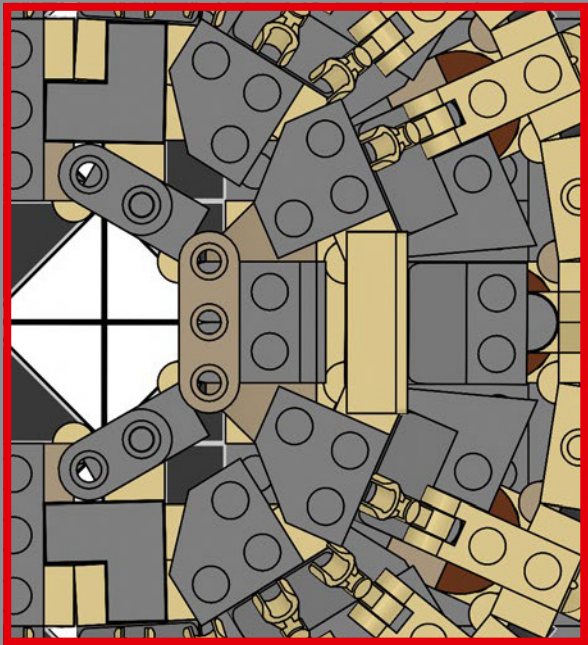
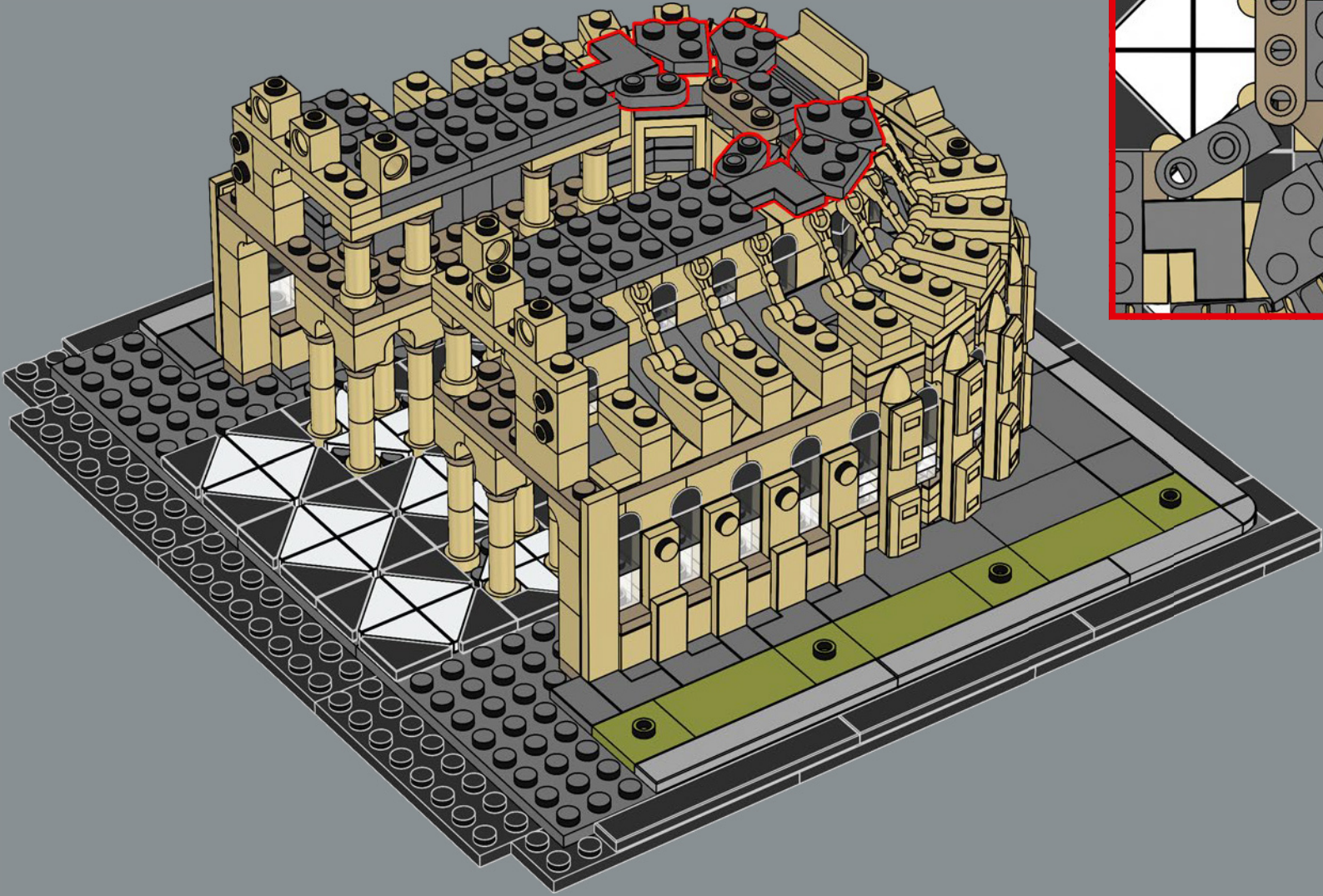



99

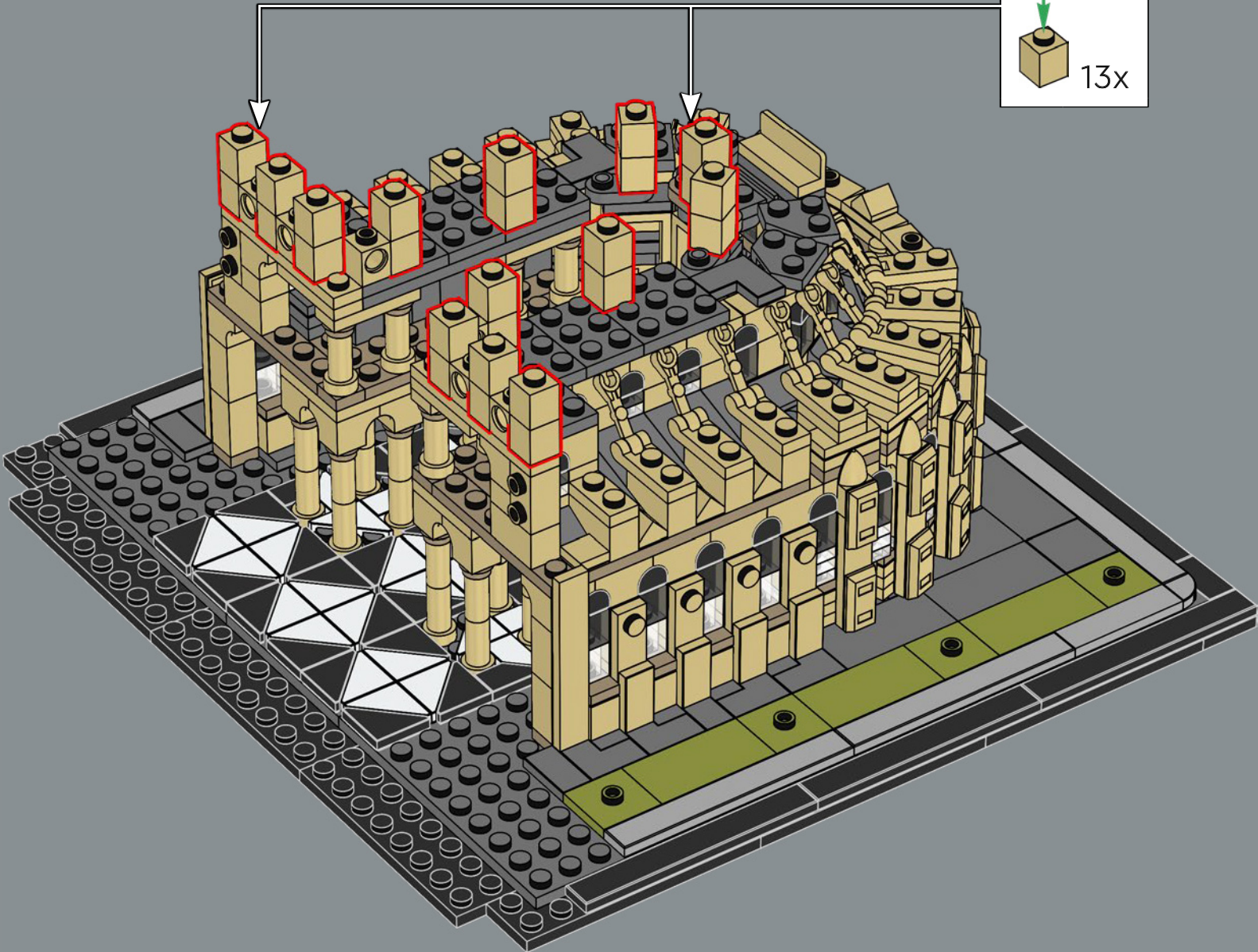
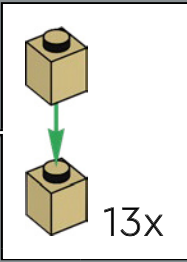

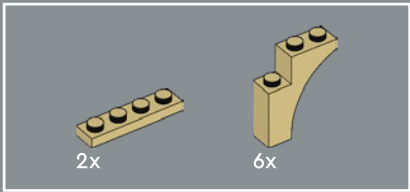

100

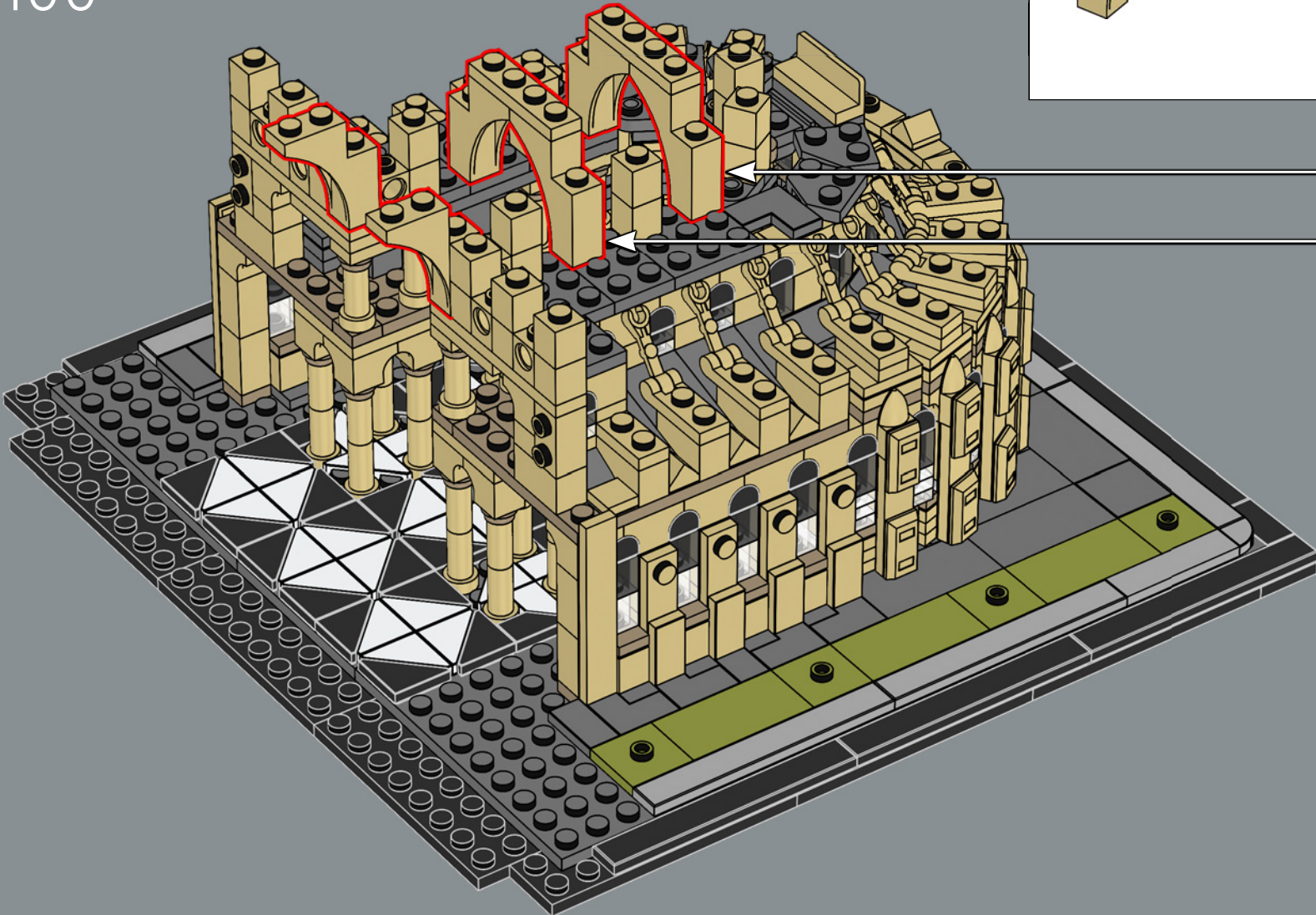
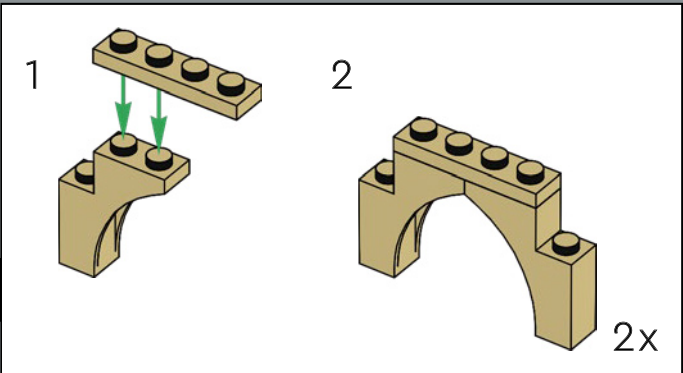

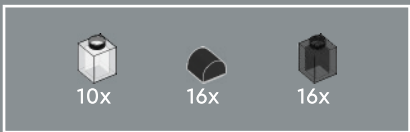

101

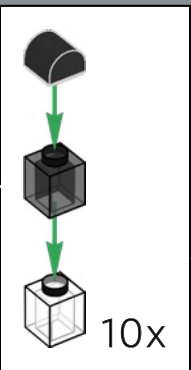
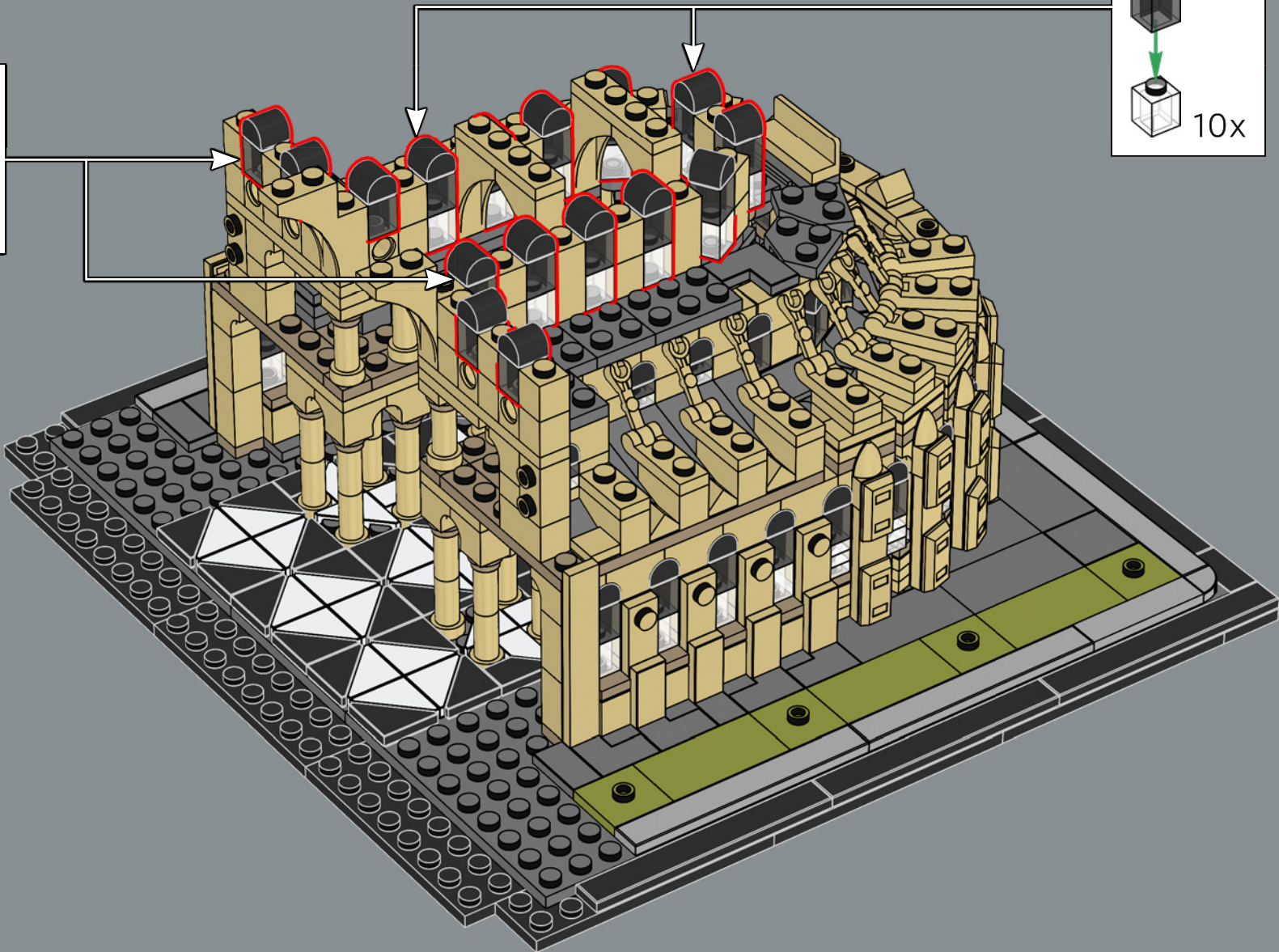
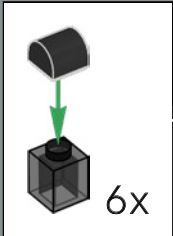

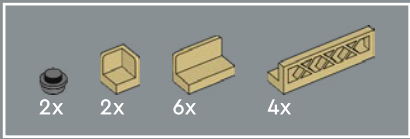

102

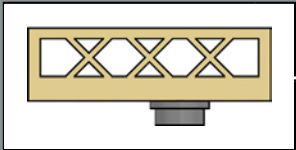
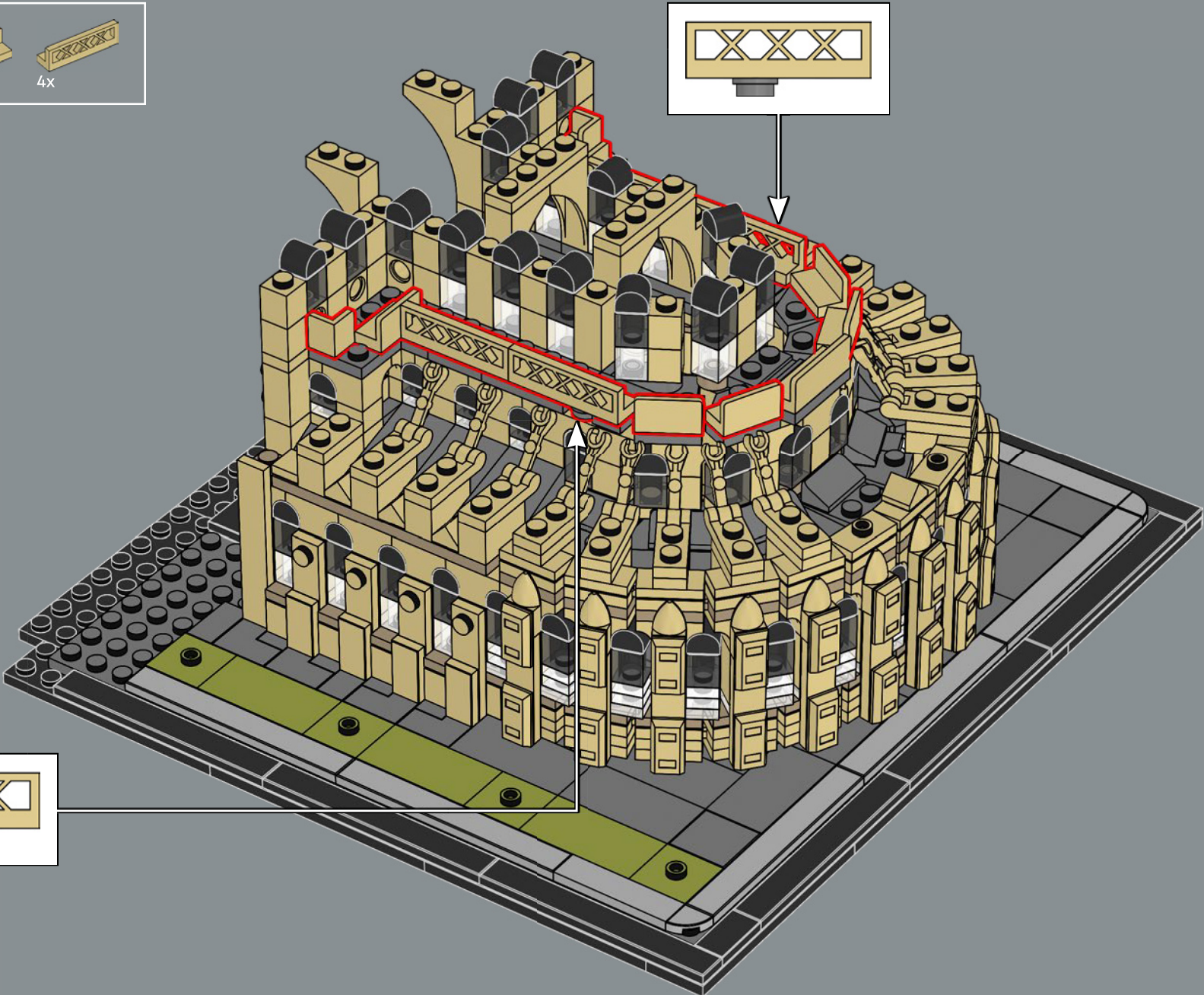

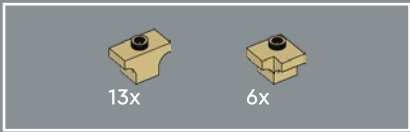

103

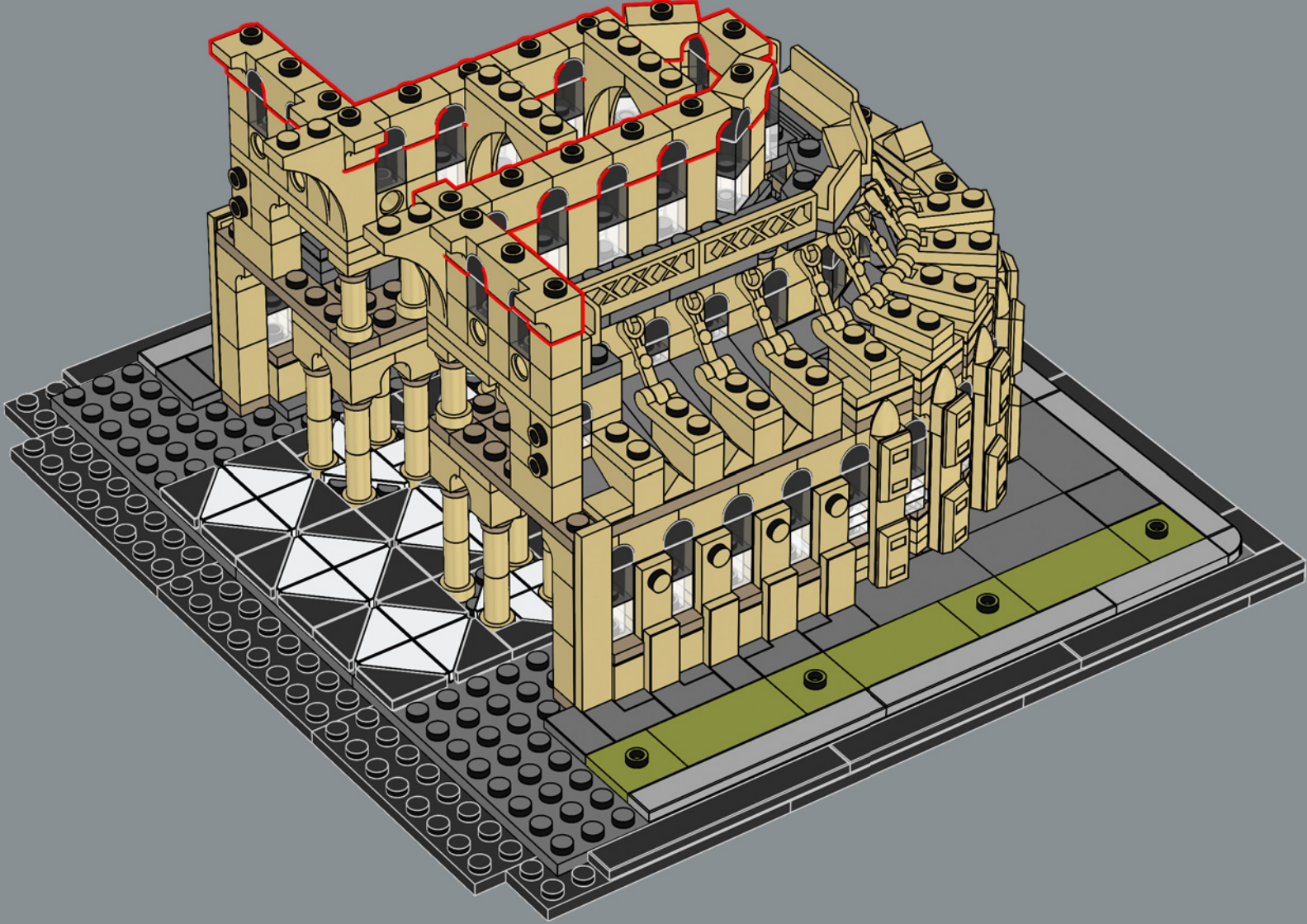

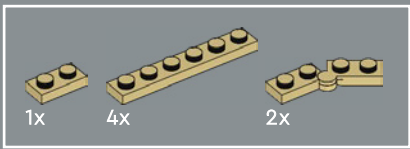

104

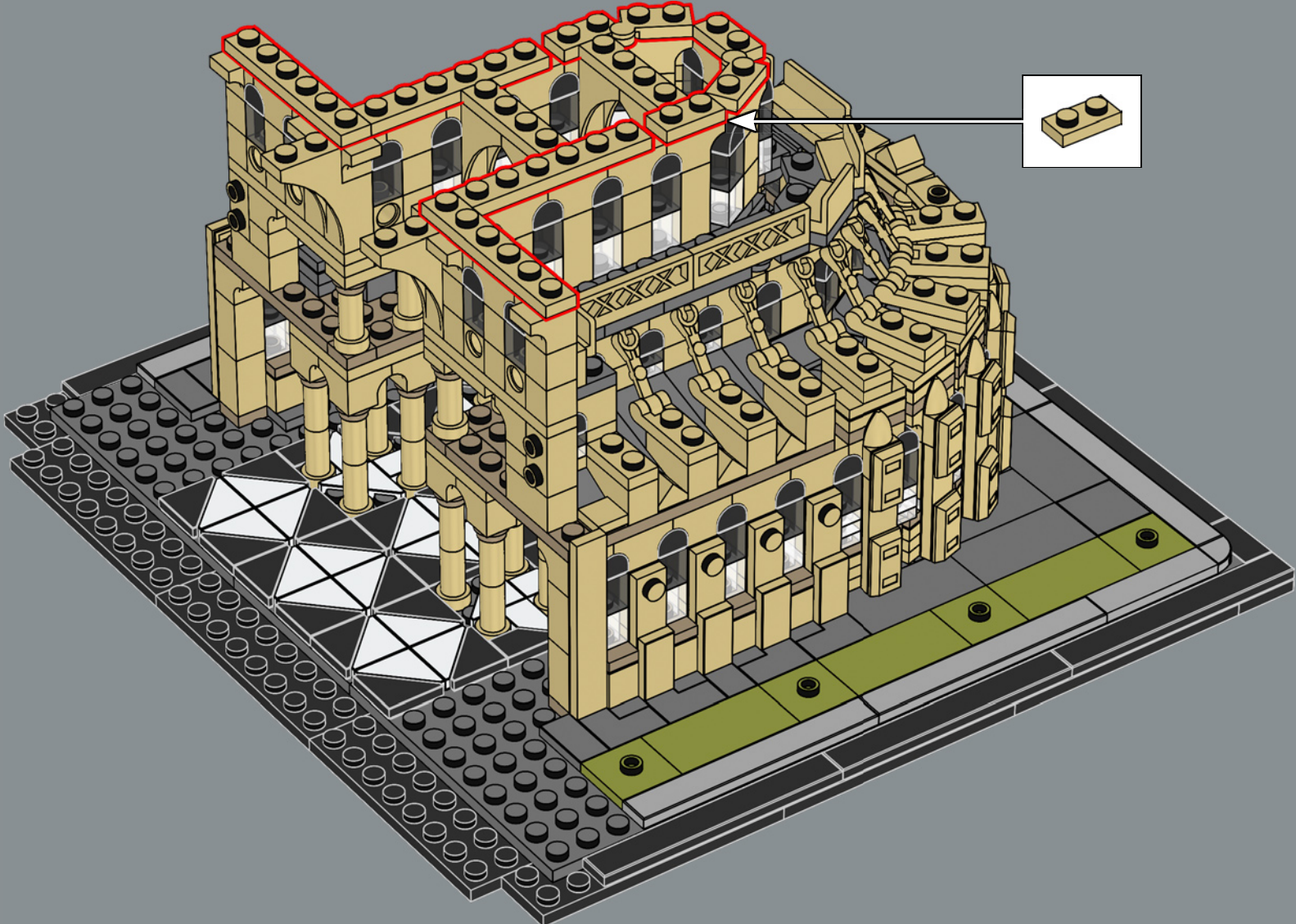

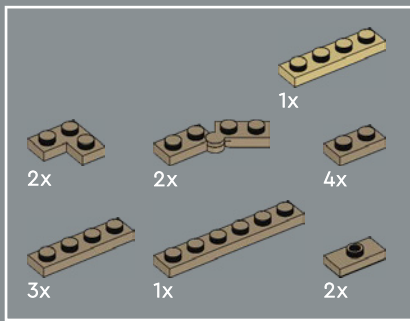

105

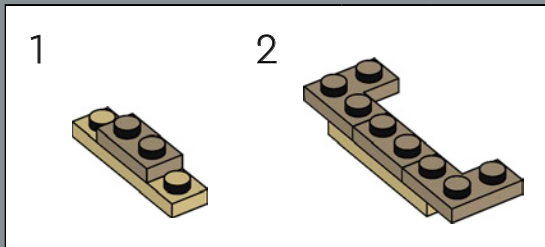
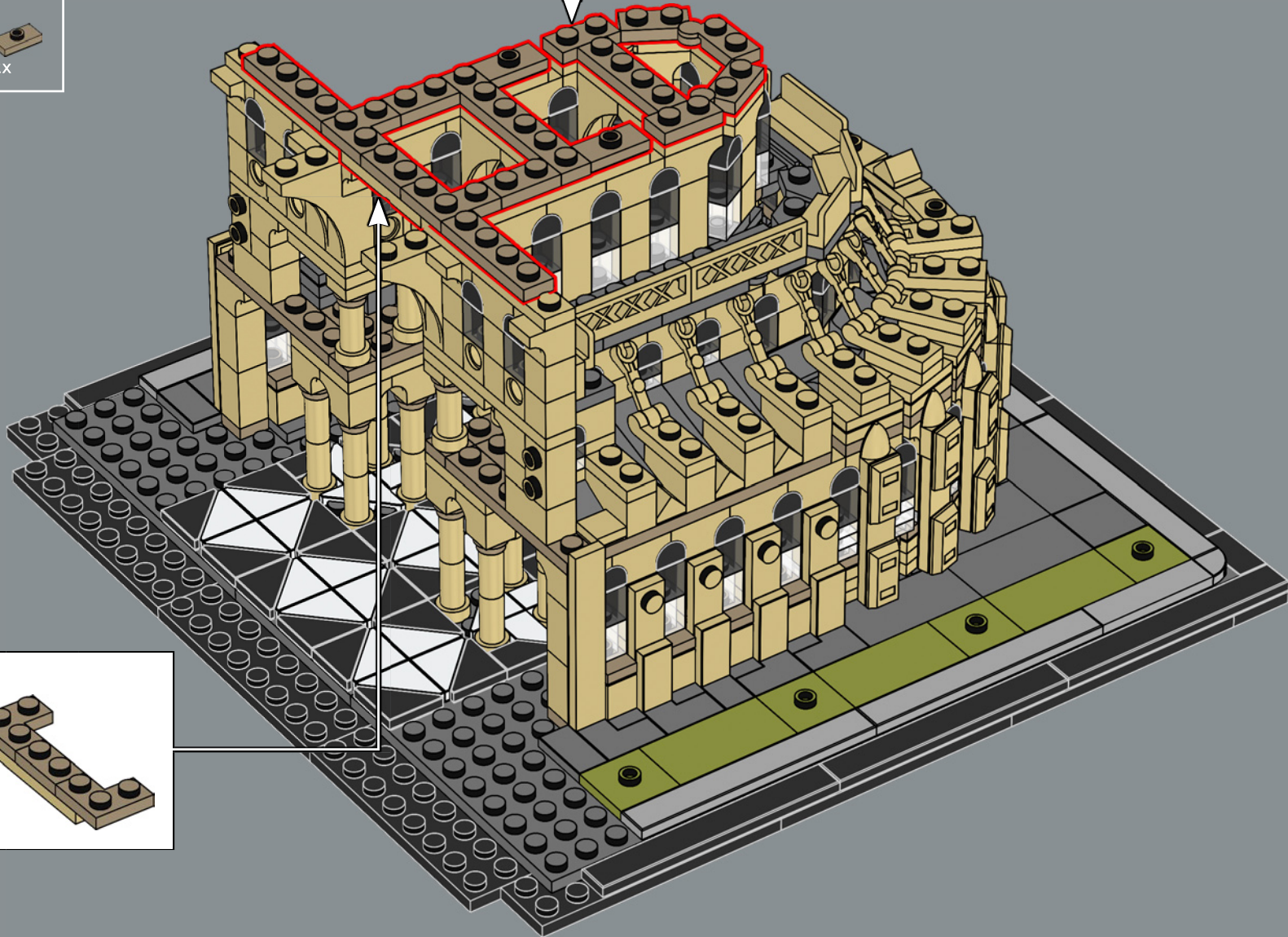
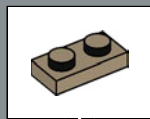

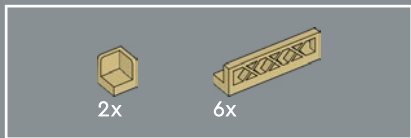

106

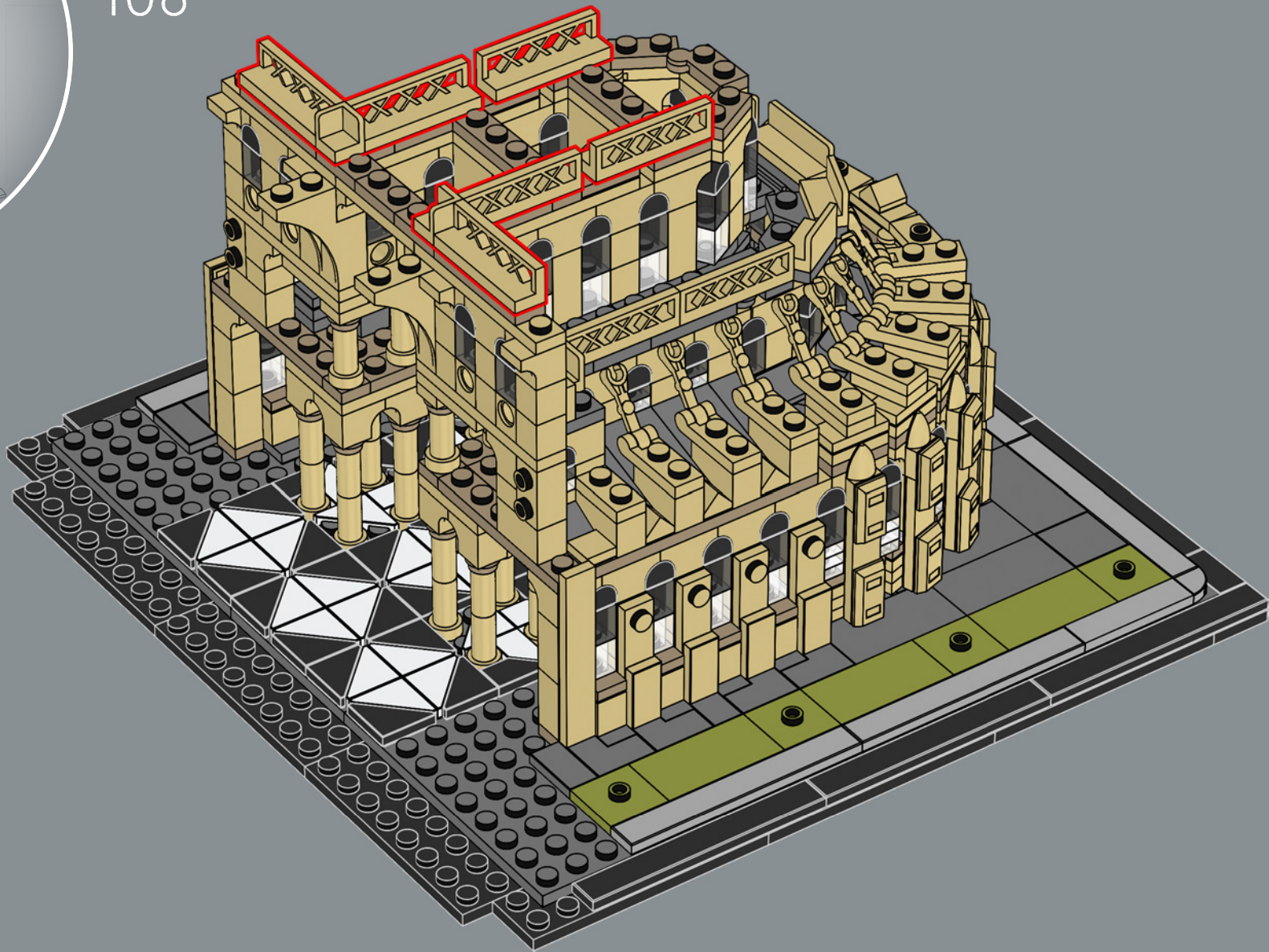

6x 10x

4x

6x

107

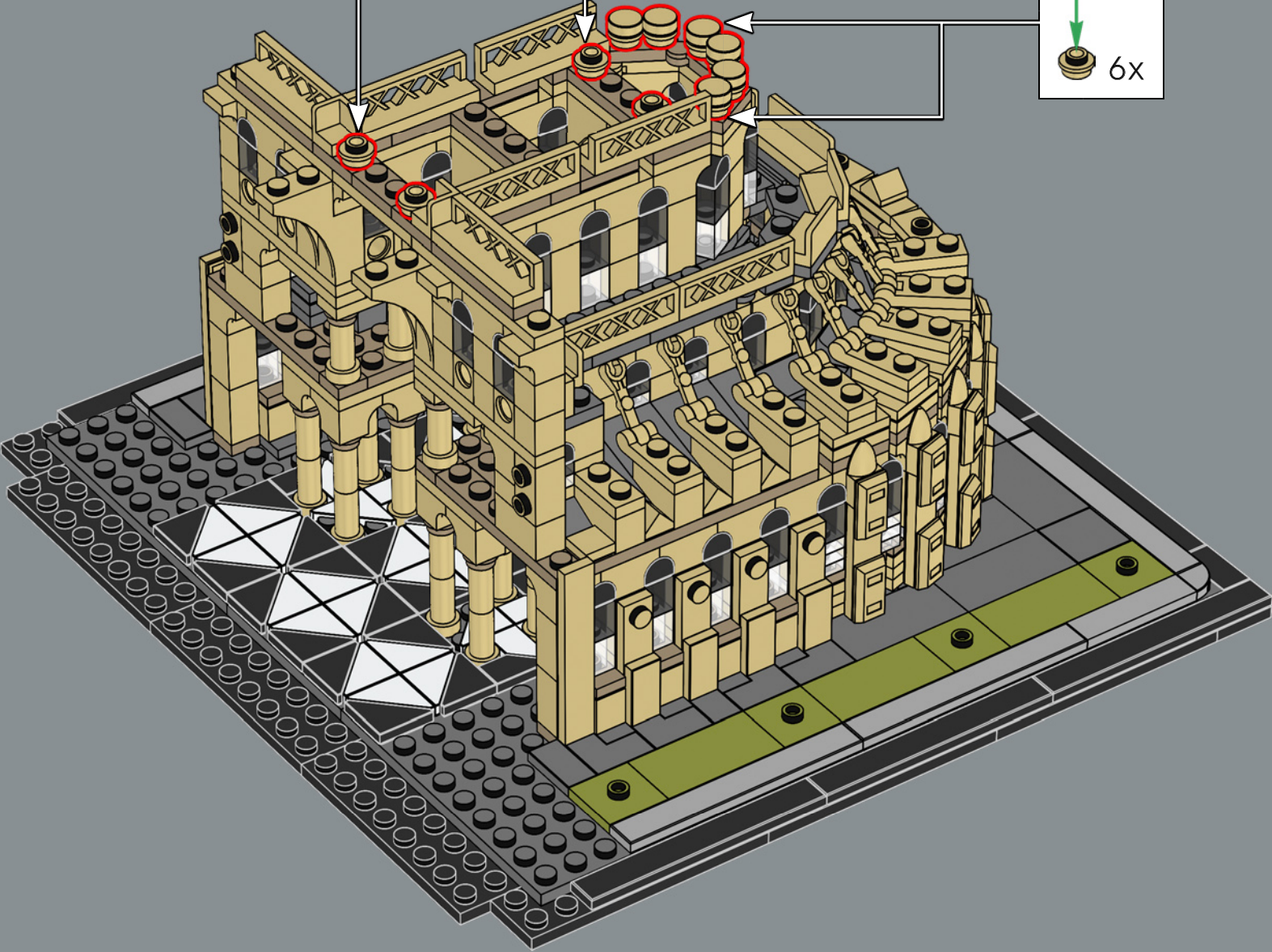

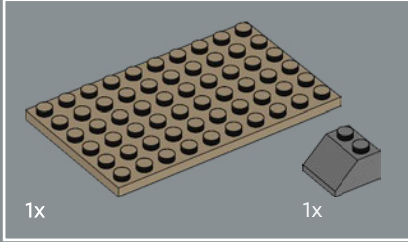
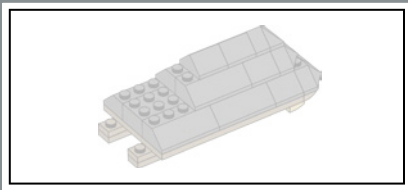

108

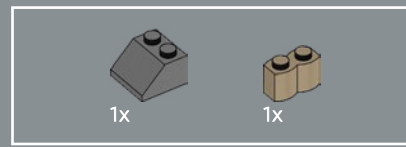
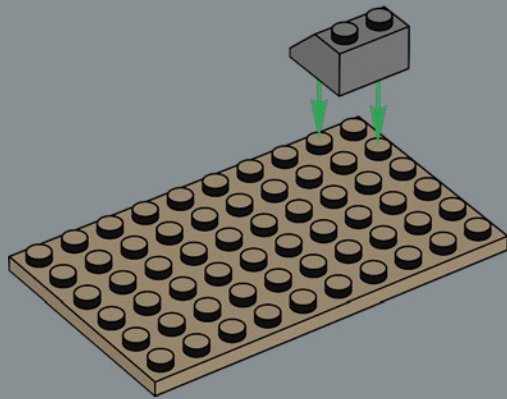

109

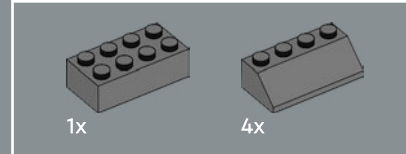
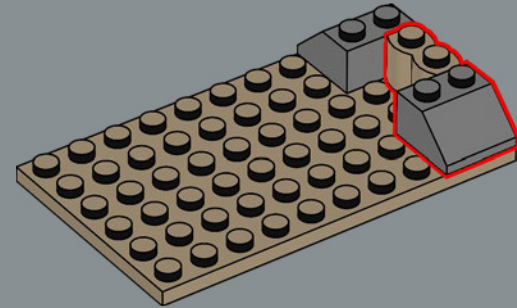

110

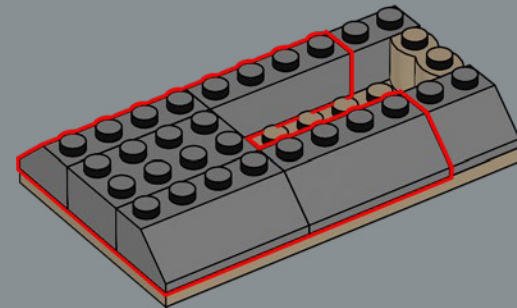

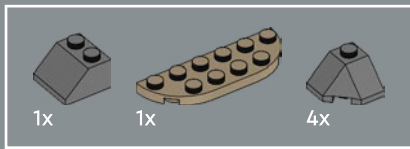

111

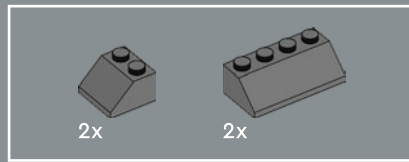
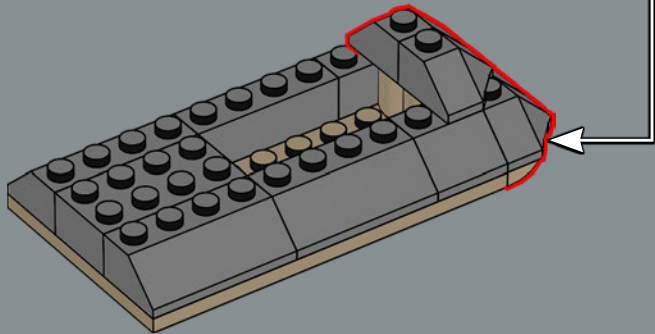

112

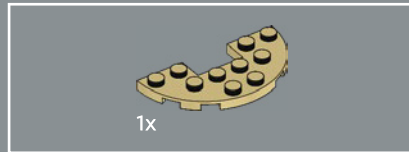
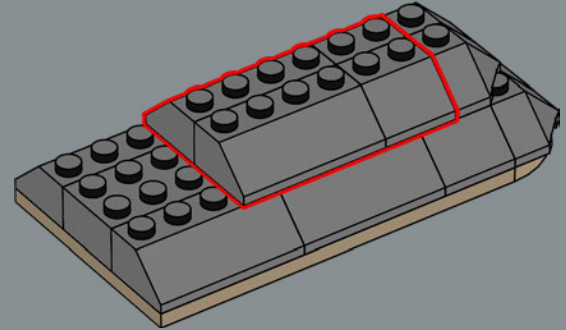

113

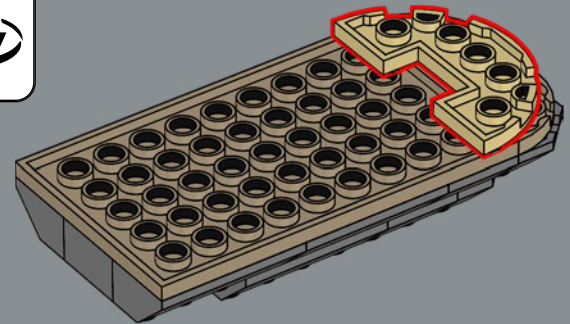

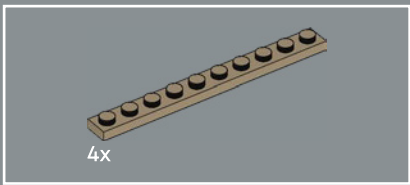

114

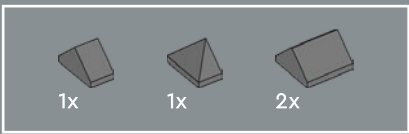
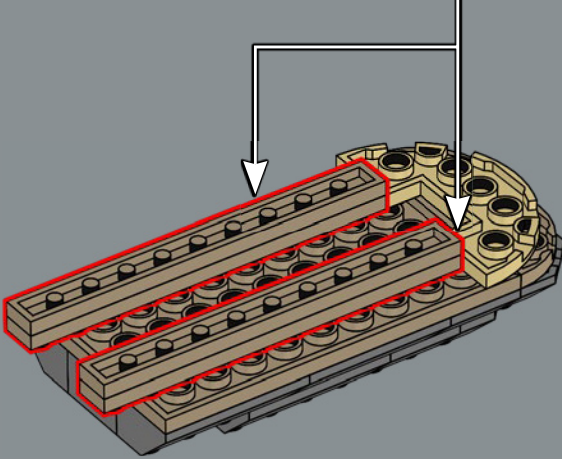
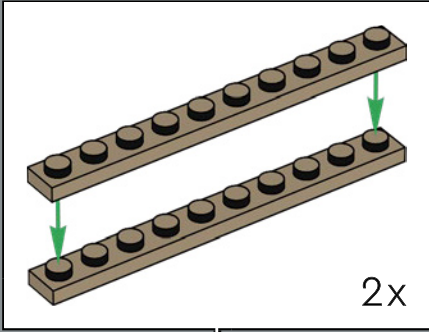

115

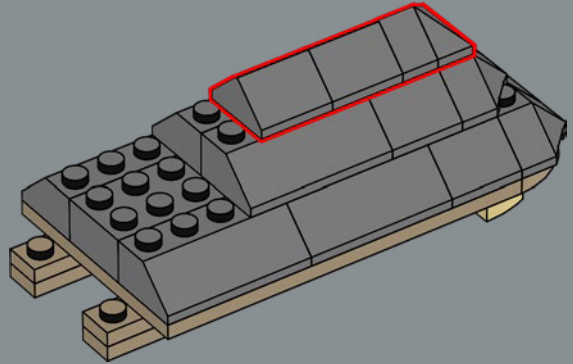

116

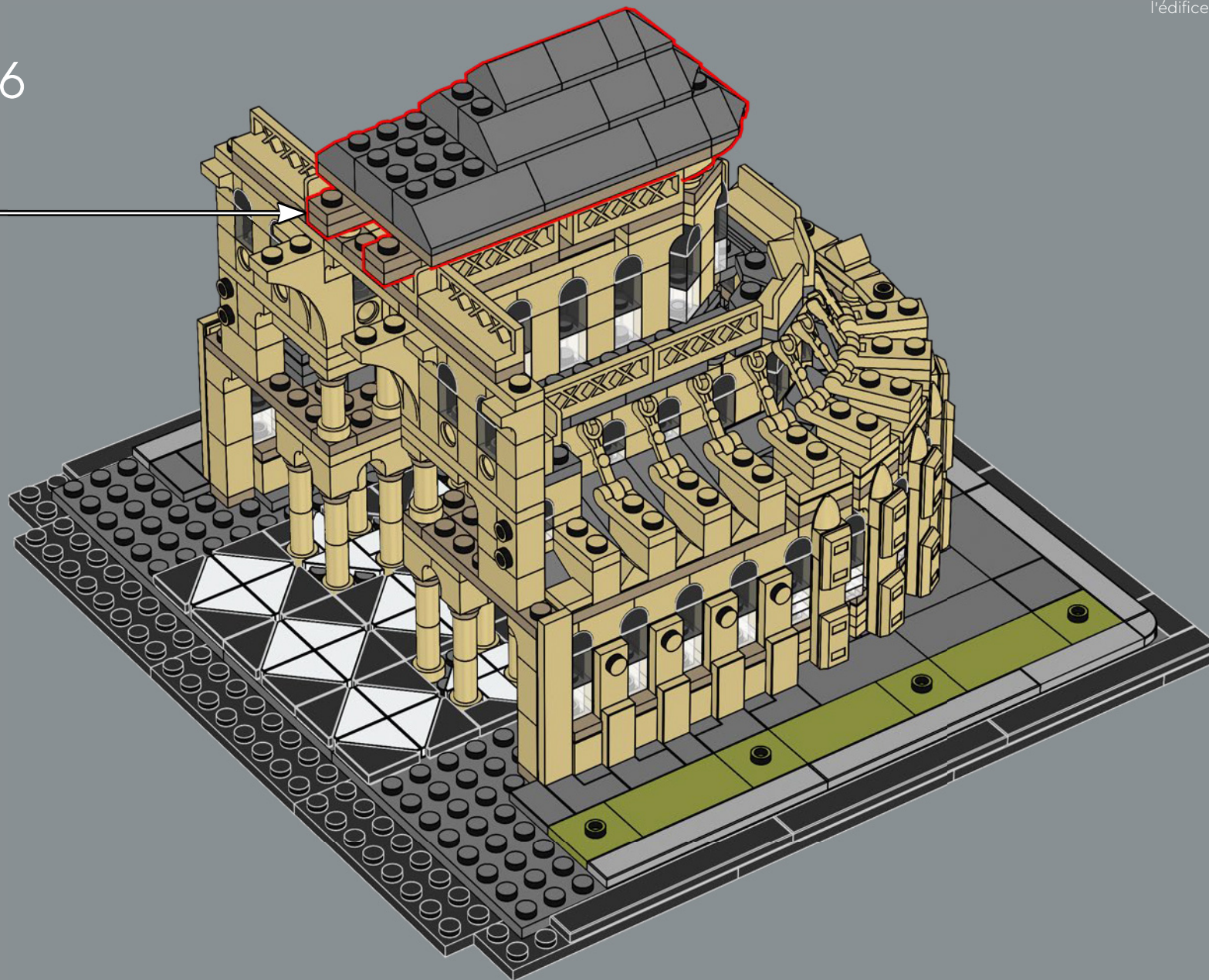

1177 - Le chœur et le chevet sont pratiquement achevés, à l'exception des voûtes hautes. Le toit et la charpente en bois sont construits avant les voûtes afin de protéger l'édifice contre les détériorations.

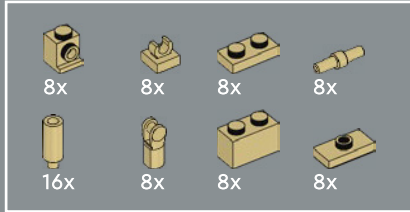
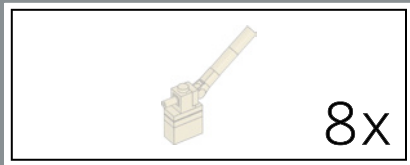

117

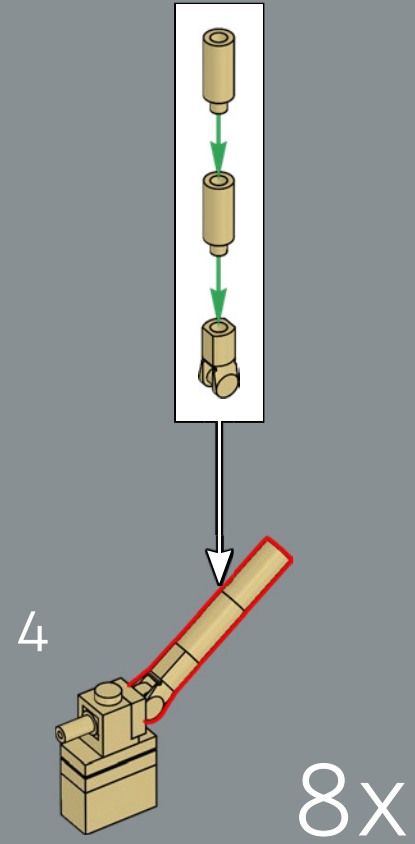
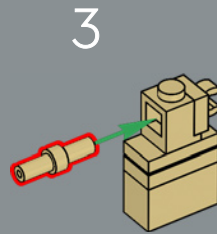
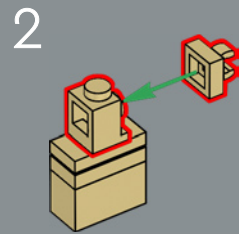
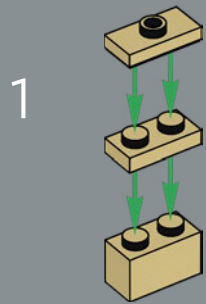

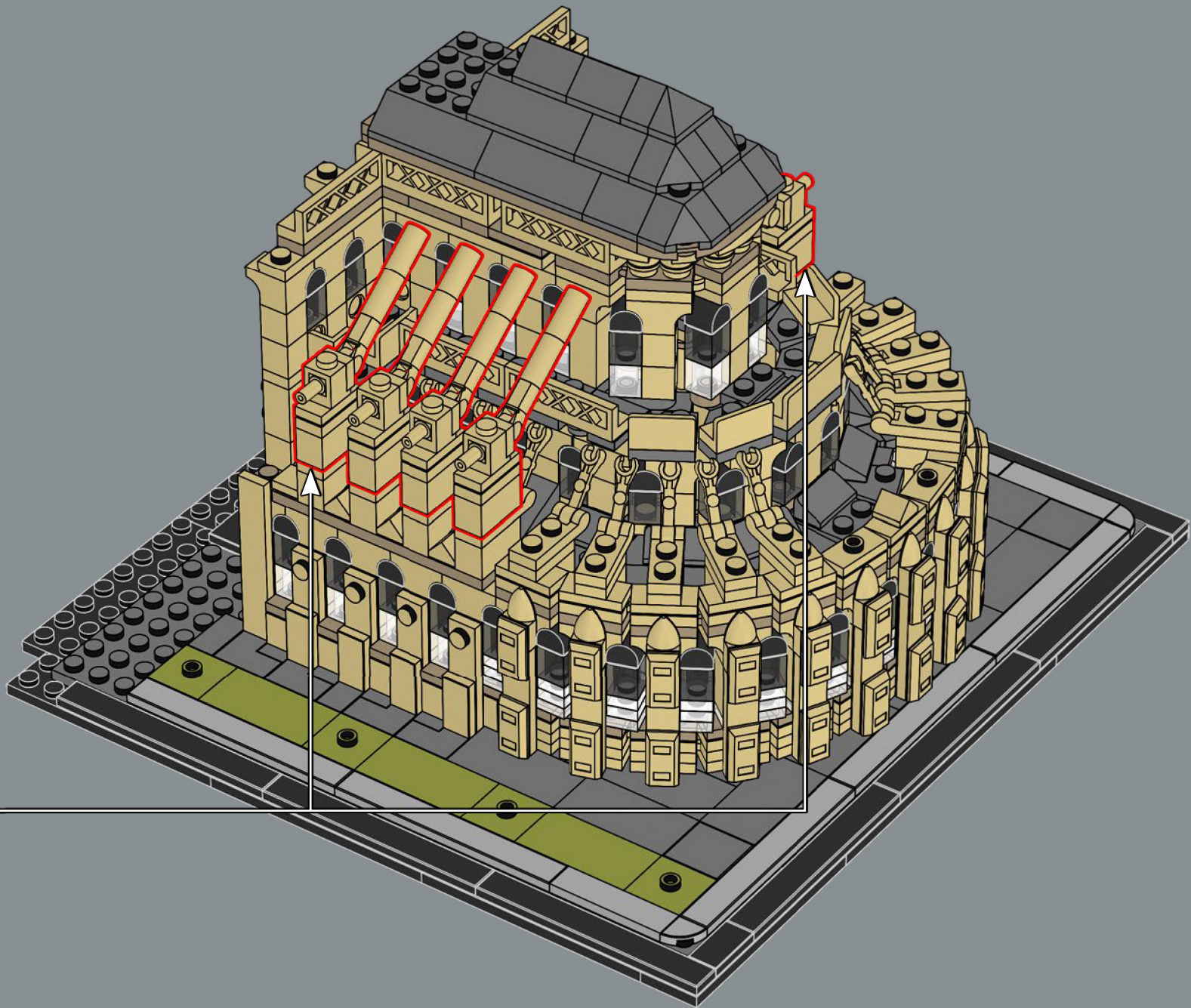

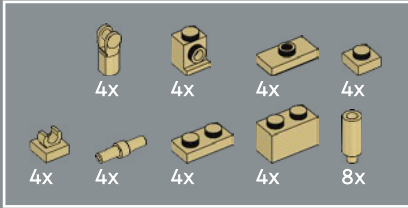
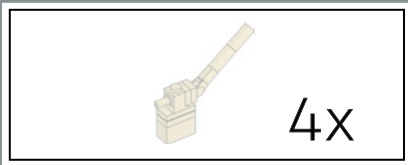

118

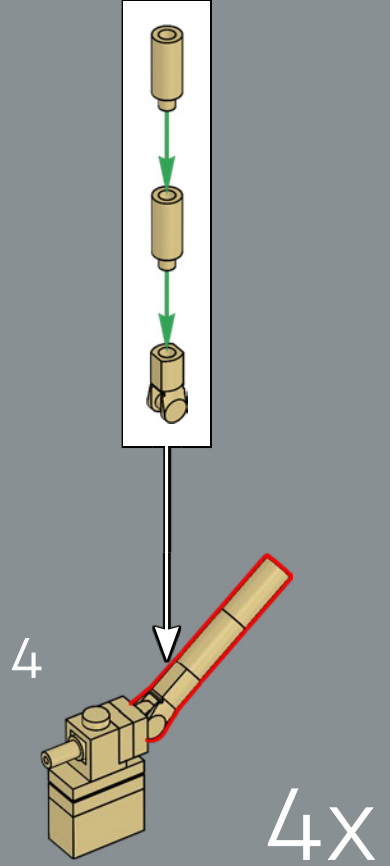
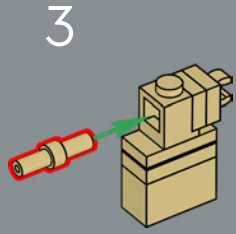
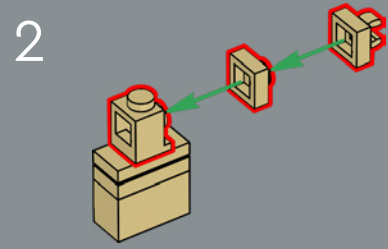
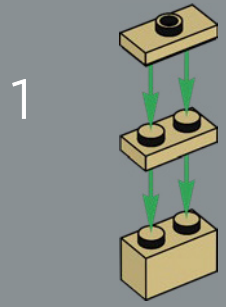

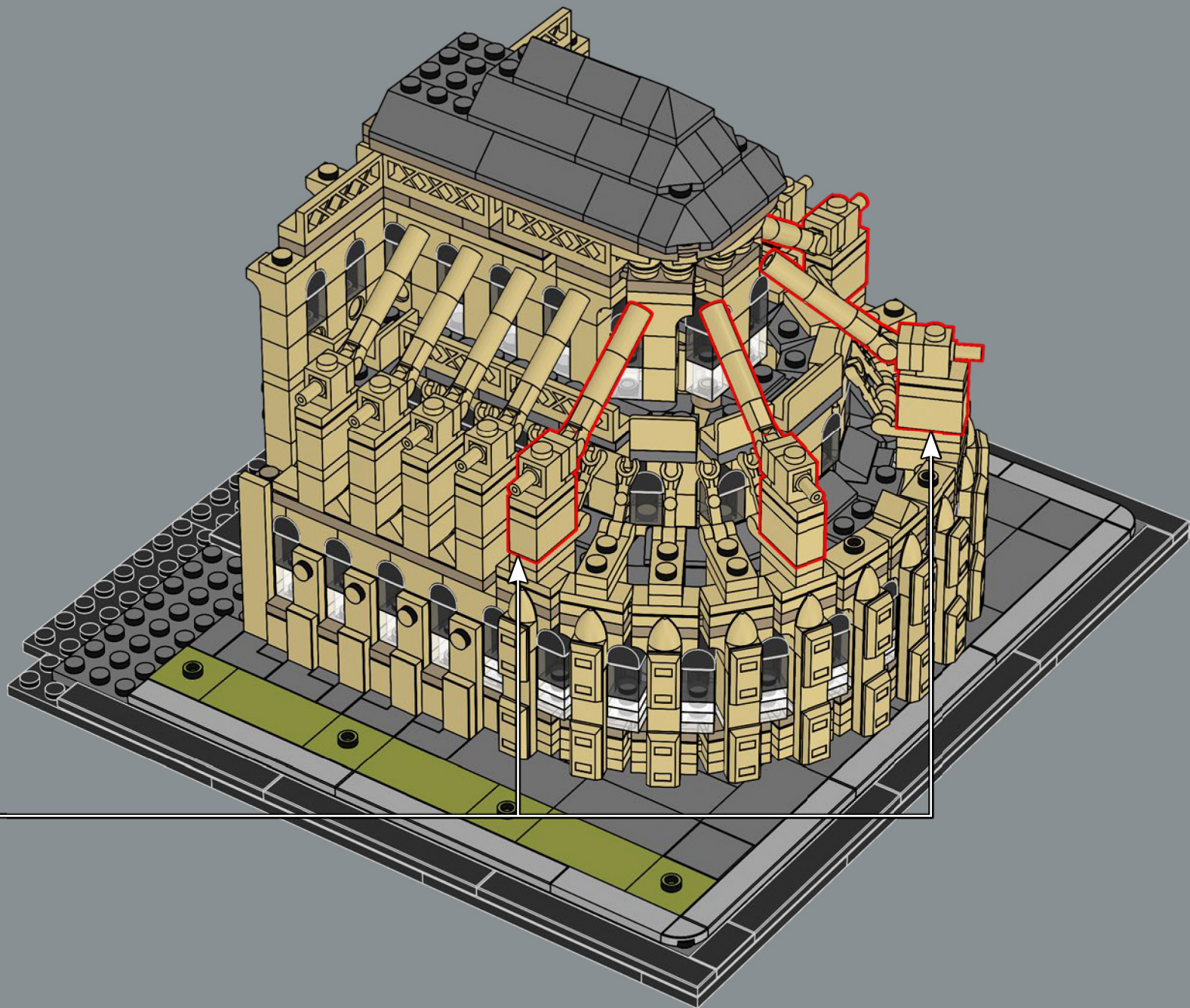

La cathédrale Notre-Dame est la première à intégrer pleinement les arcs-boutants caractéristiques de l'architecture gothique.

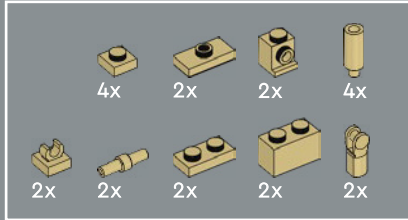
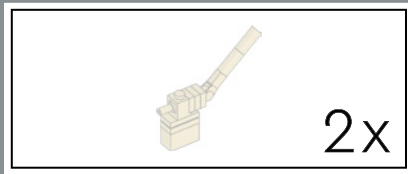

119

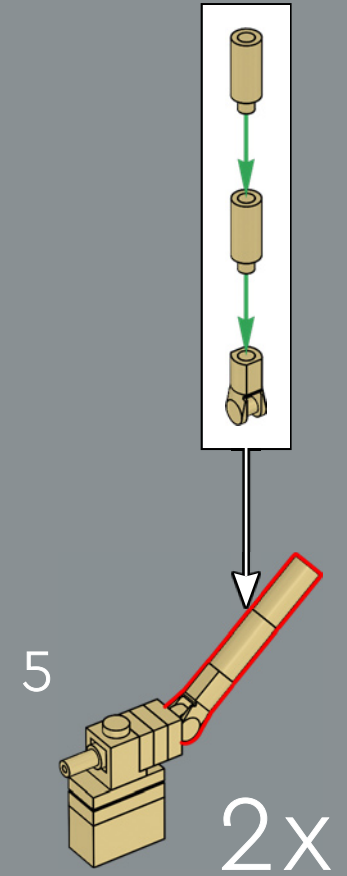
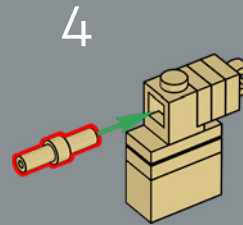
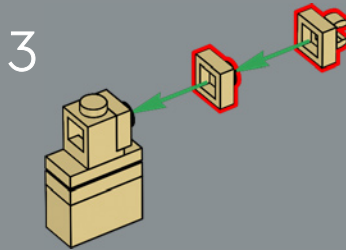
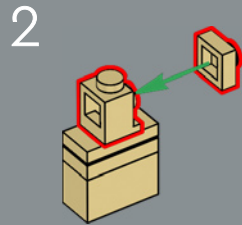
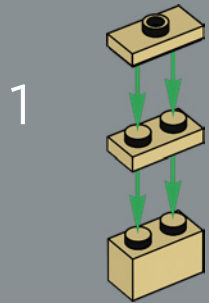

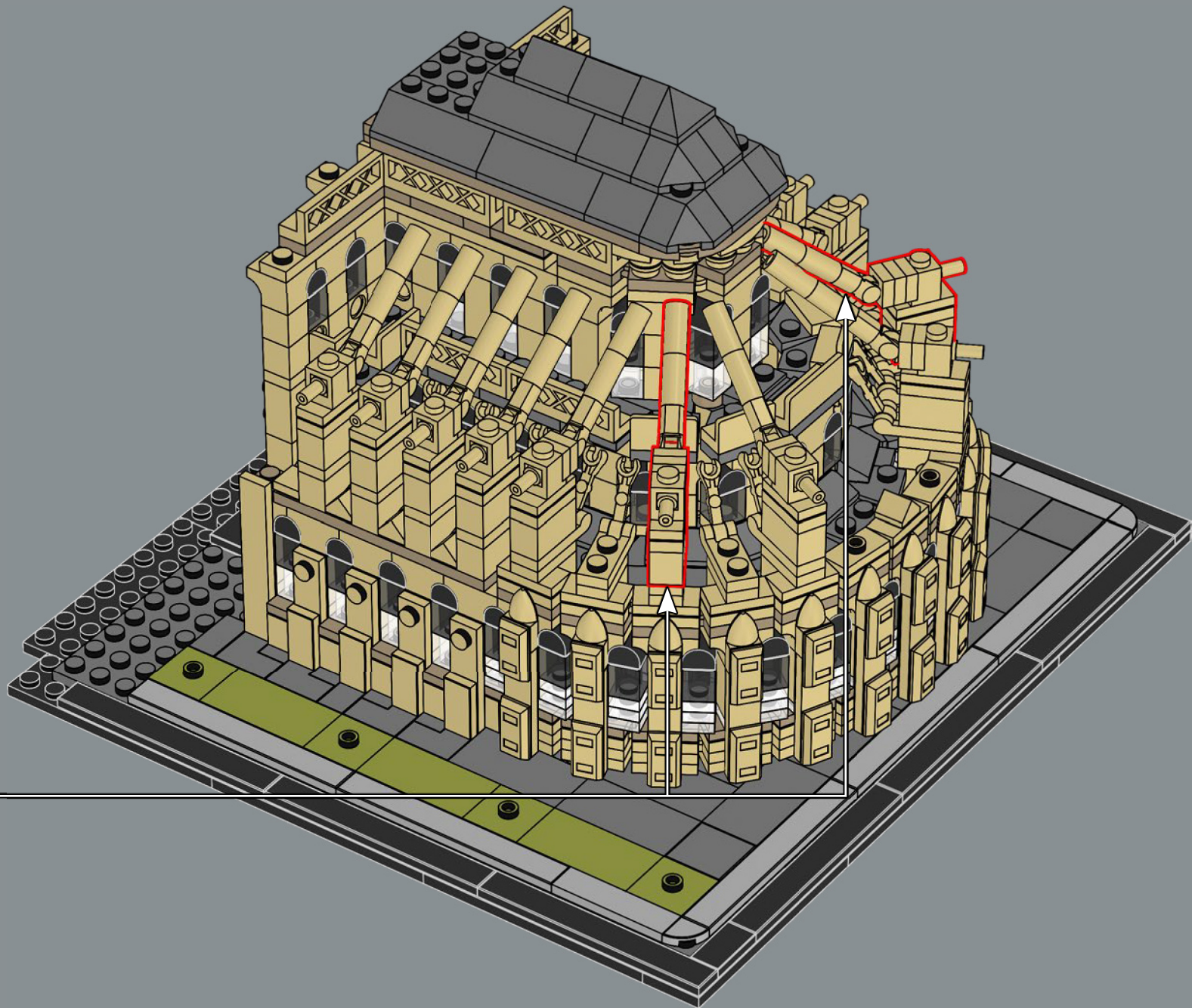

UN MONUMENT LEGO® PREND FORME

1182-1200



*Les travaux se poursuivent dans le transept et
les travées du côté sud de la nef.*

✚ Mesurant 128 m de long, 48 m de large et 69 m de haut, la cathédrale Notre-Dame a été construite sur le site d'une cathédrale romane, bâtie sur l'île de la Cité, entre les deux bras de la Seine. Alors que la première partie orientale achevée sert d'église provisoire, les travaux de construction se poursuivent sur le transept et dans les premières travées du côté sud de la nef. Originellement conçue dans le style roman, la construction intègre progressivement des styles architecturaux contemporains, évoluant vers le style gothique qu'elle représente aujourd'hui. Cette réplique reste fidèle à la construction de la structure intérieure et aux détails architecturaux extérieurs (dont certains ont été réduits), afin de recréer la vue à couper le souffle qui accueille les visiteurs depuis des siècles.

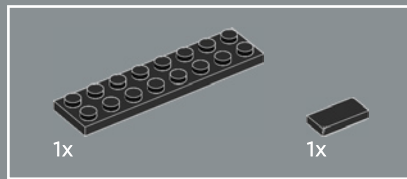
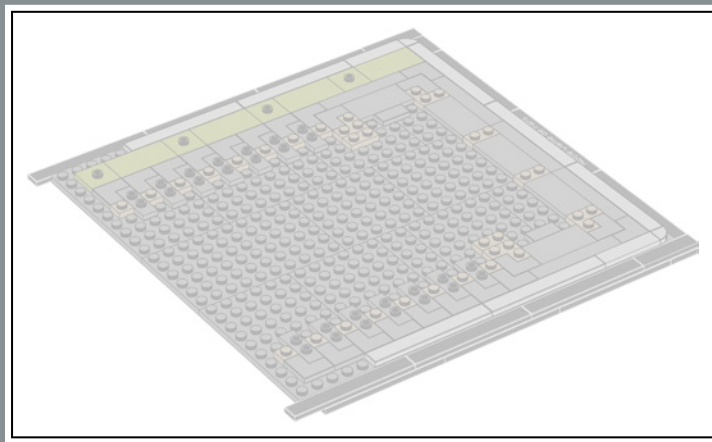

120

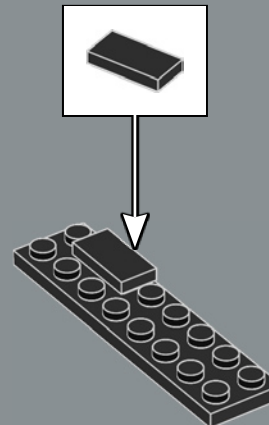

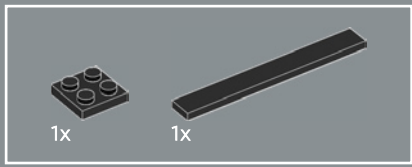

121

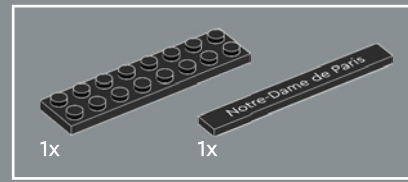
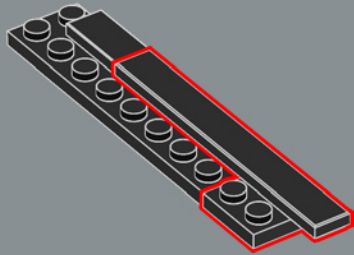

122

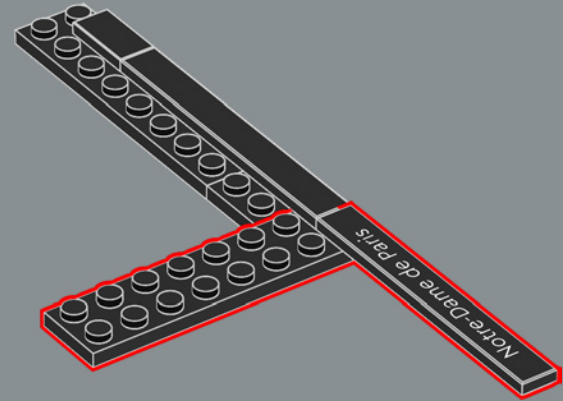

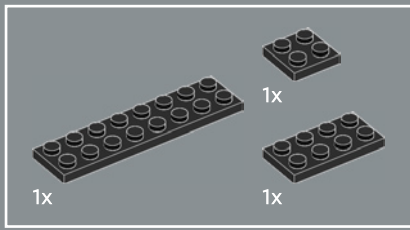

123

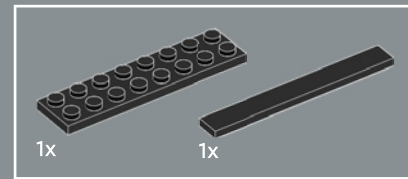
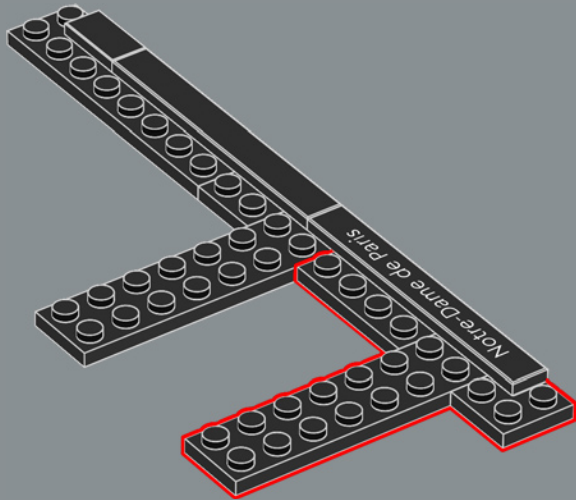

124

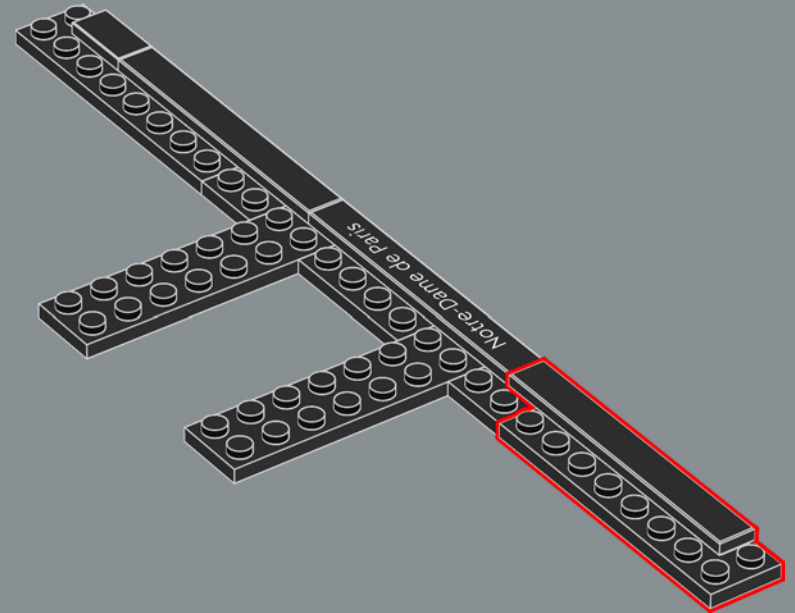

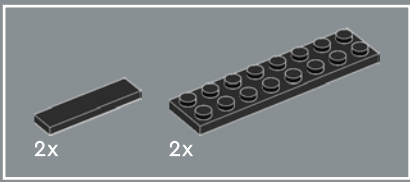

125

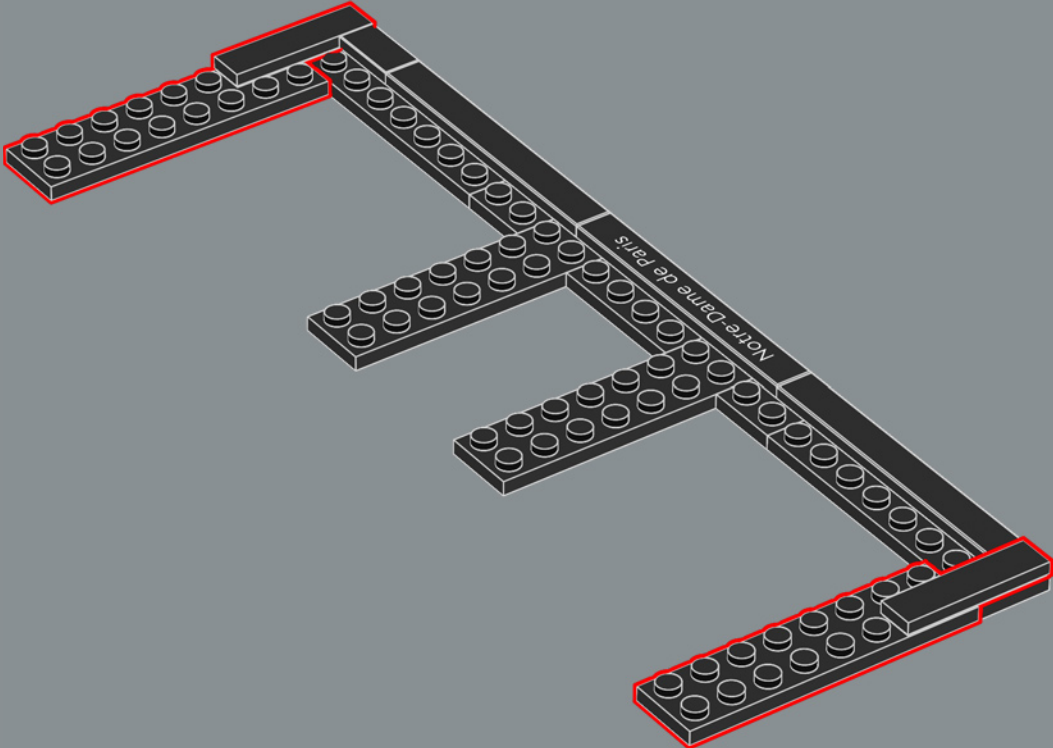

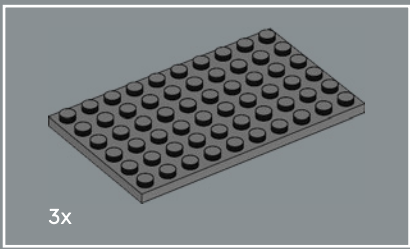

126

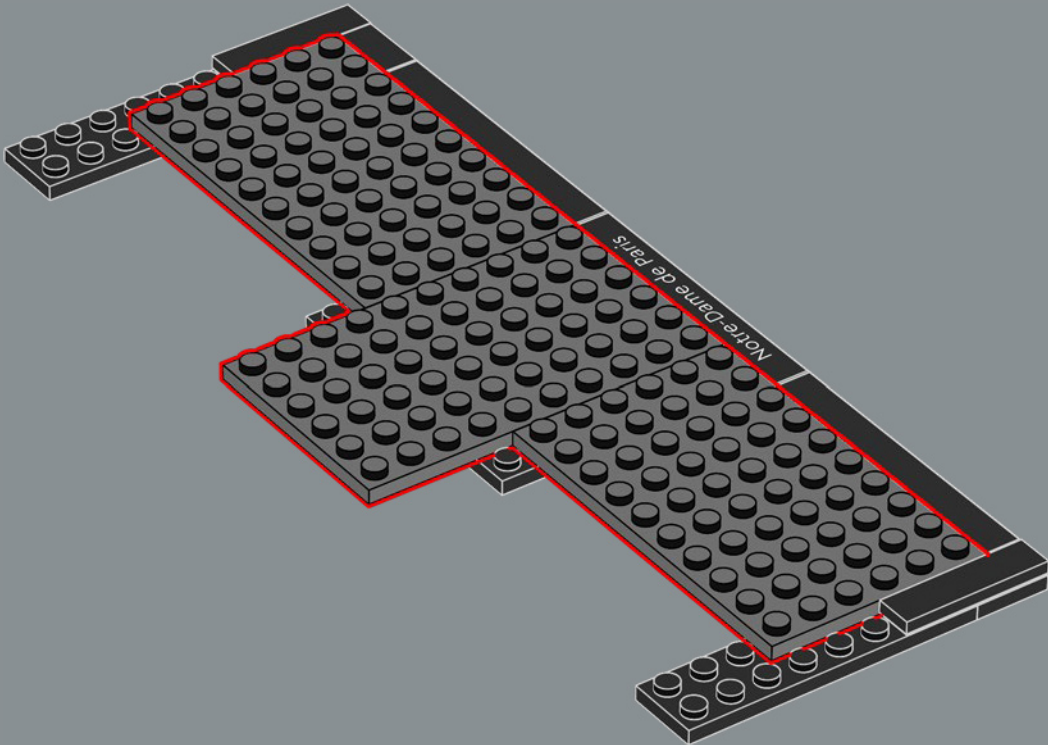

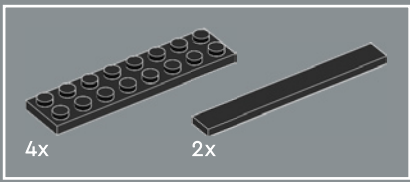

127

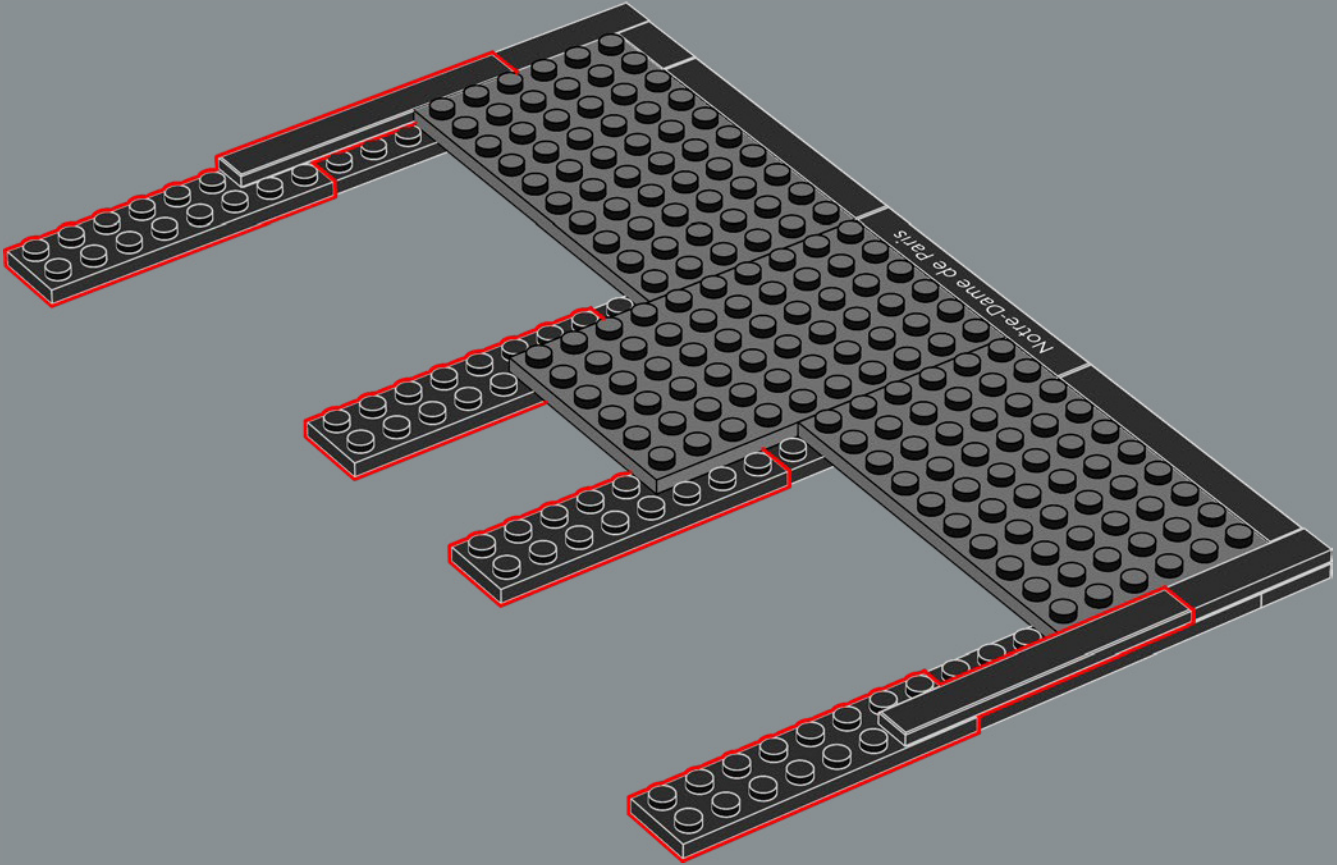

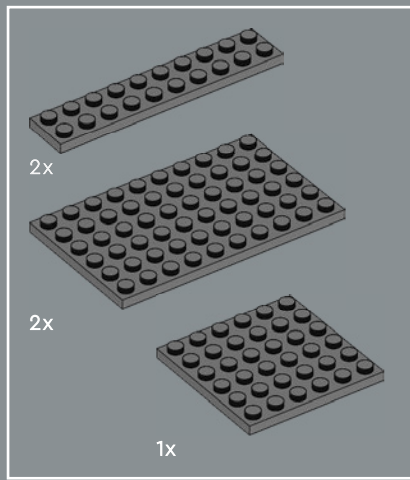

128

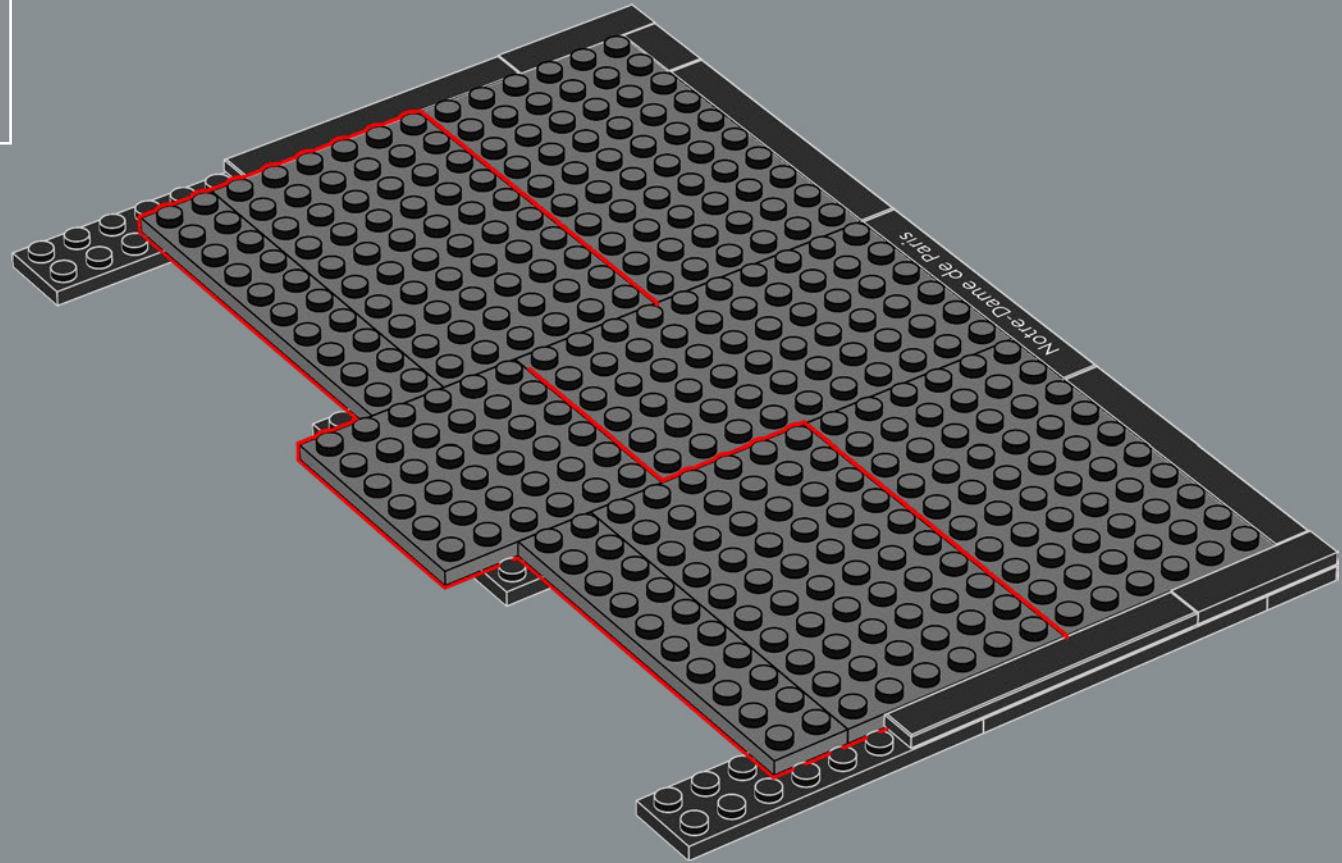

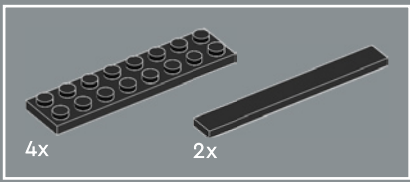

129

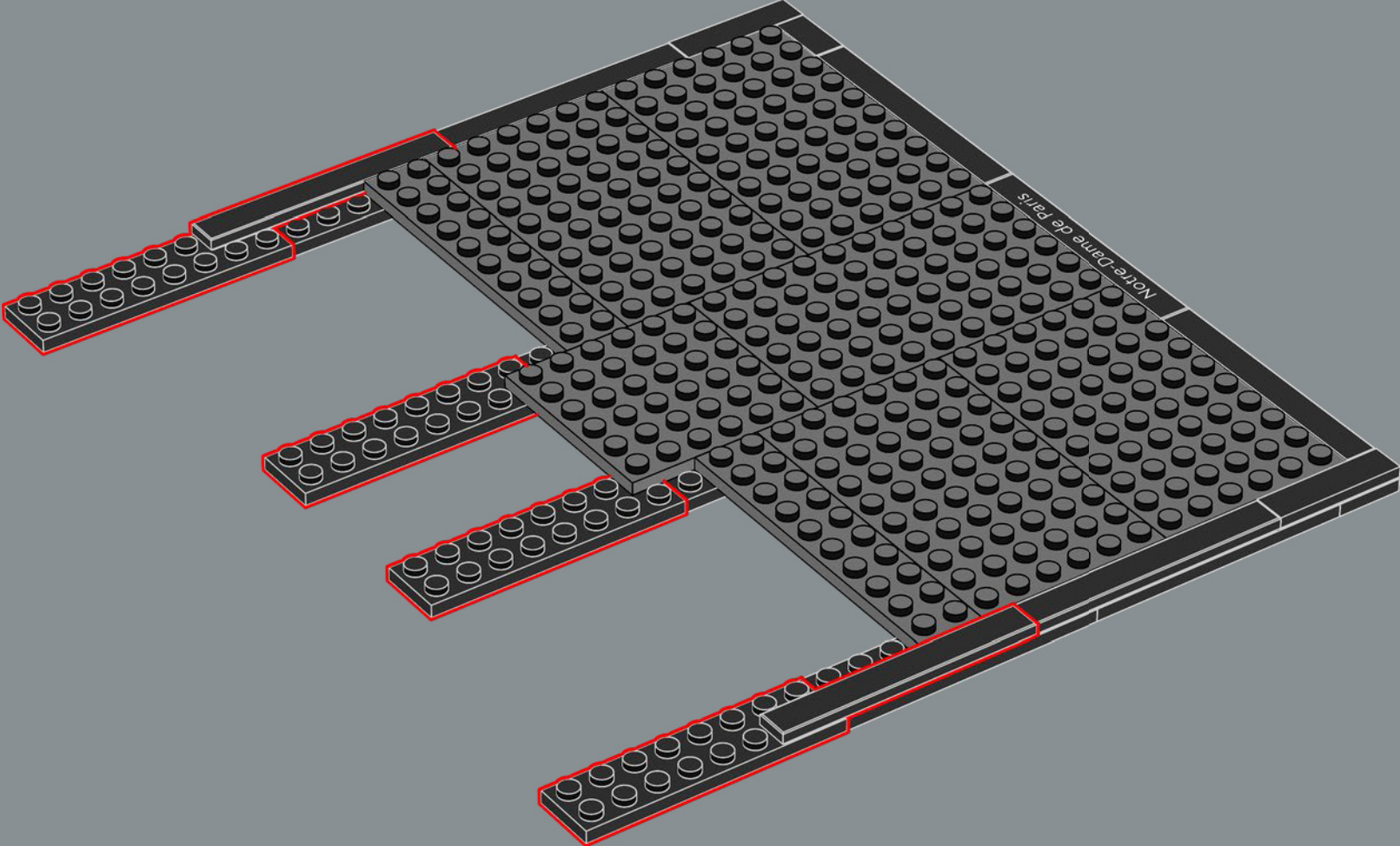

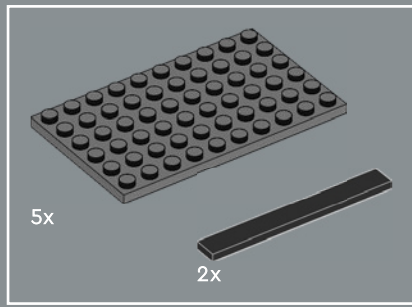

130

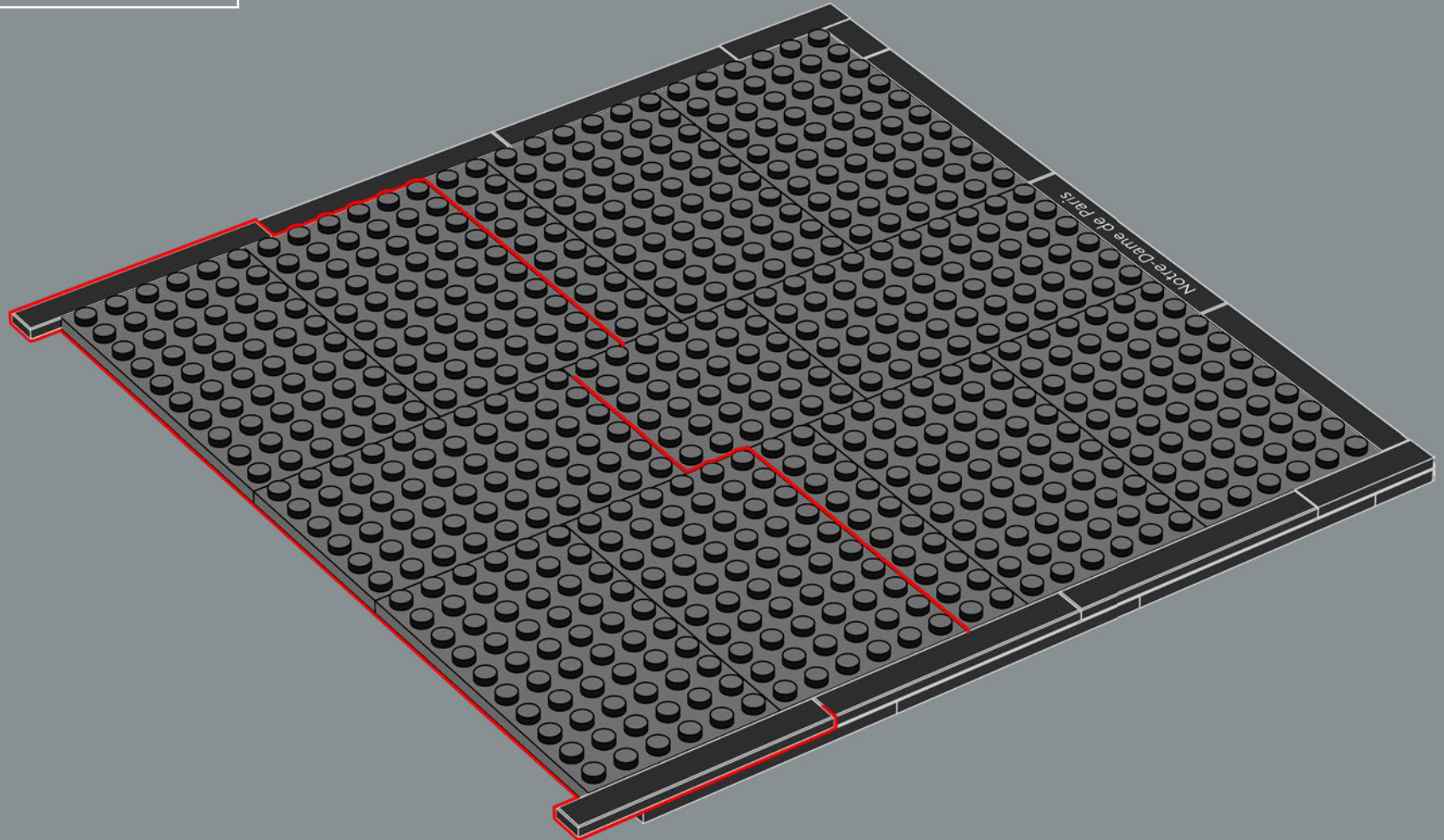

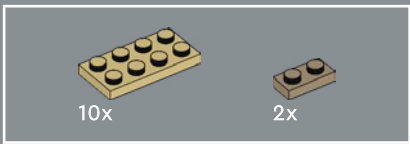

131

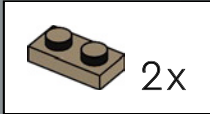
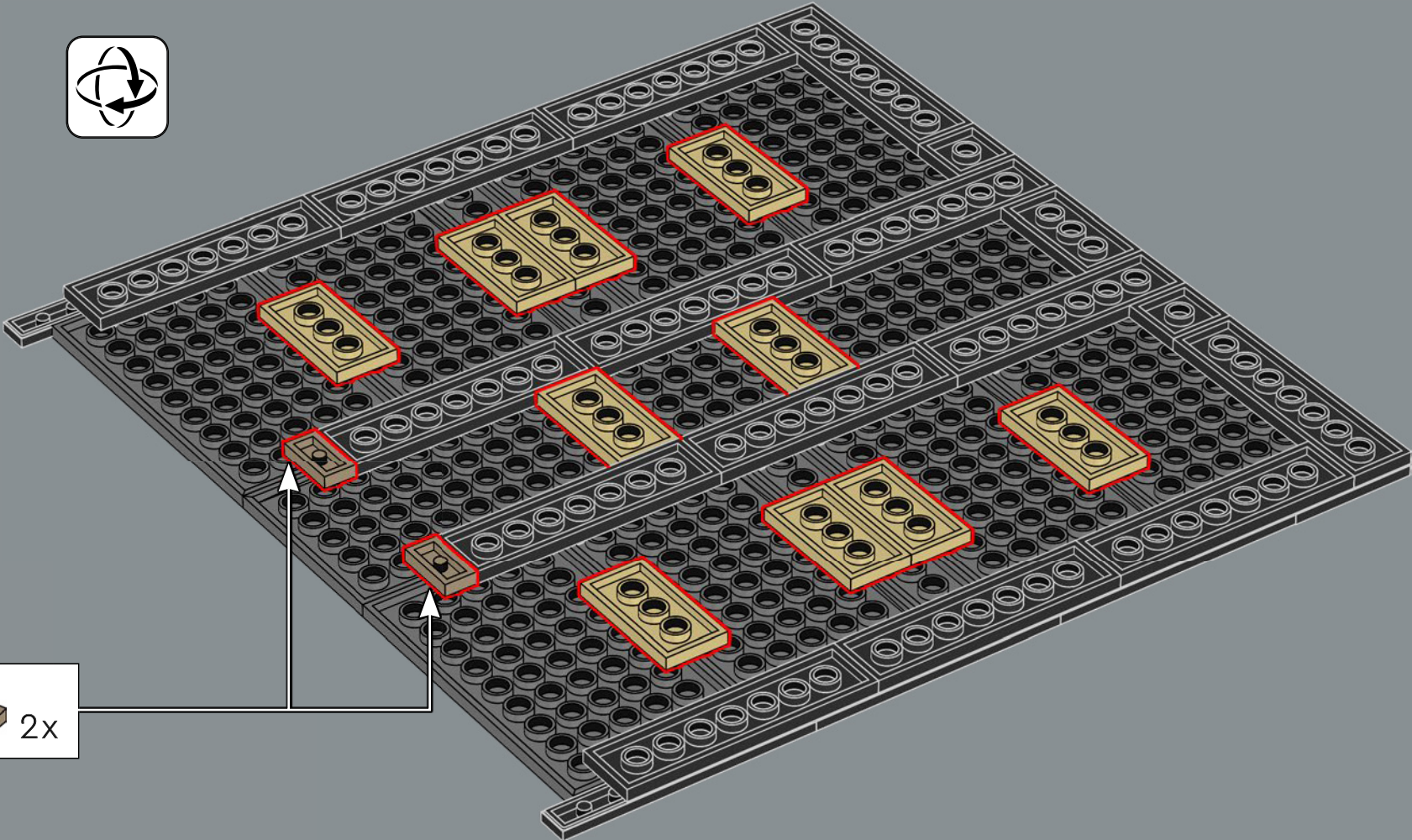

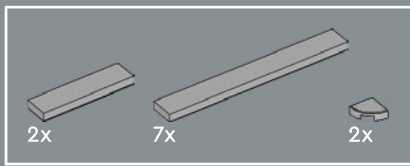

132

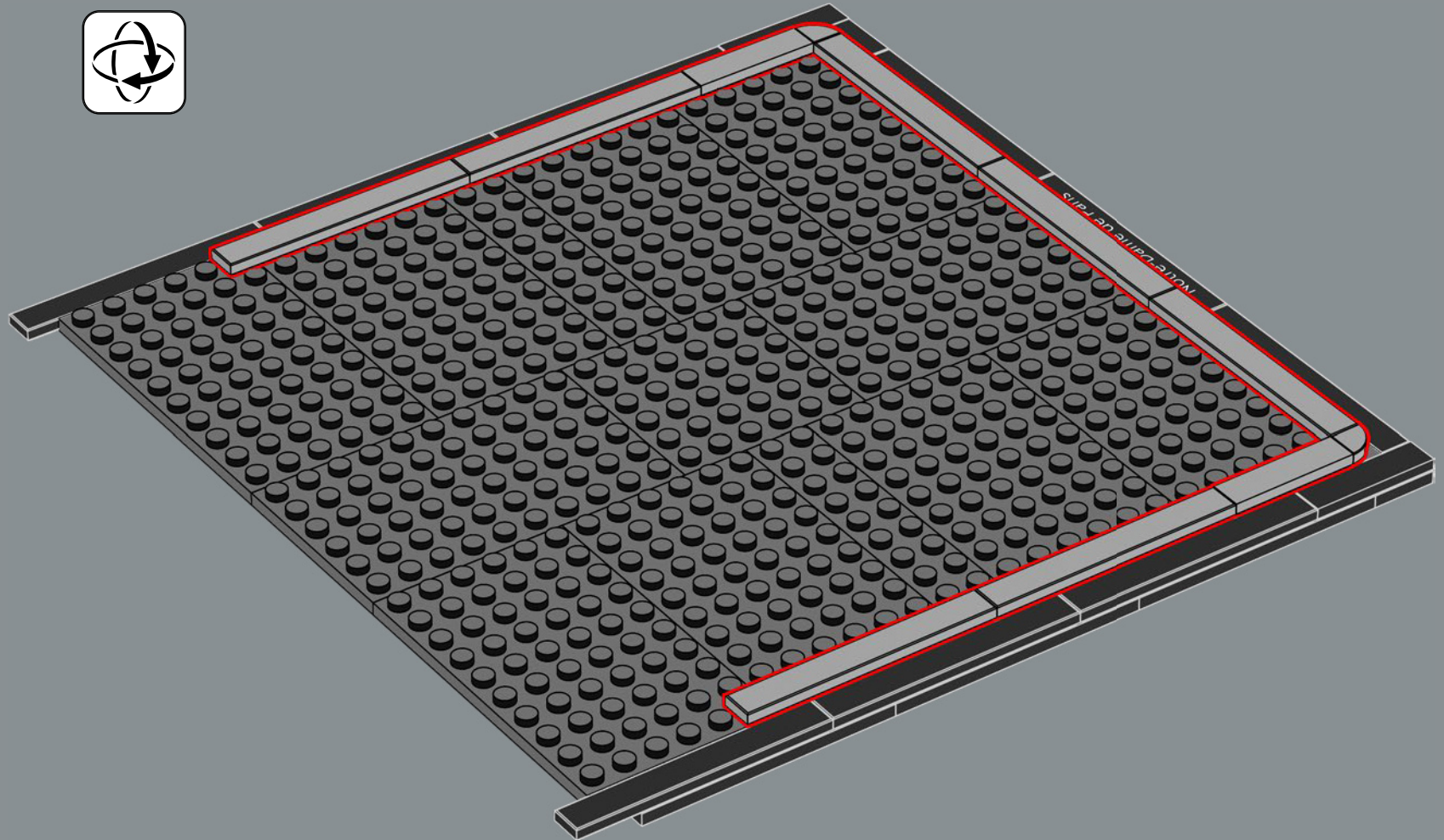

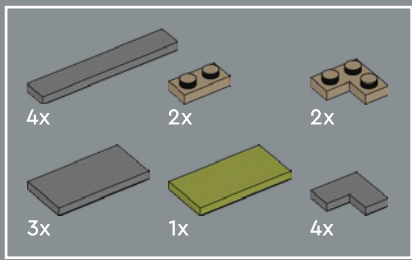

133

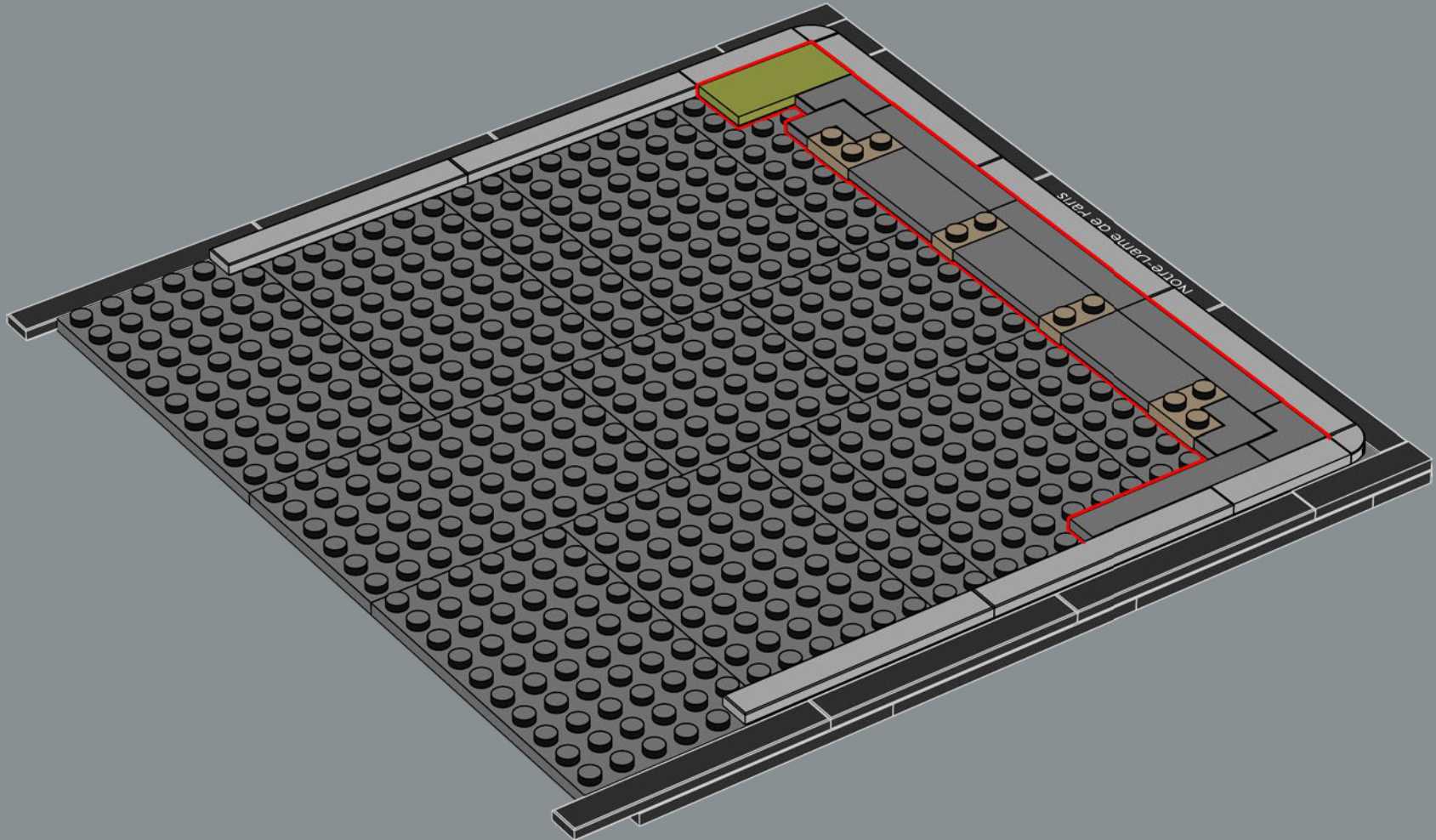

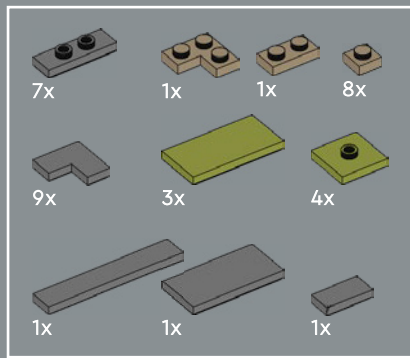

134

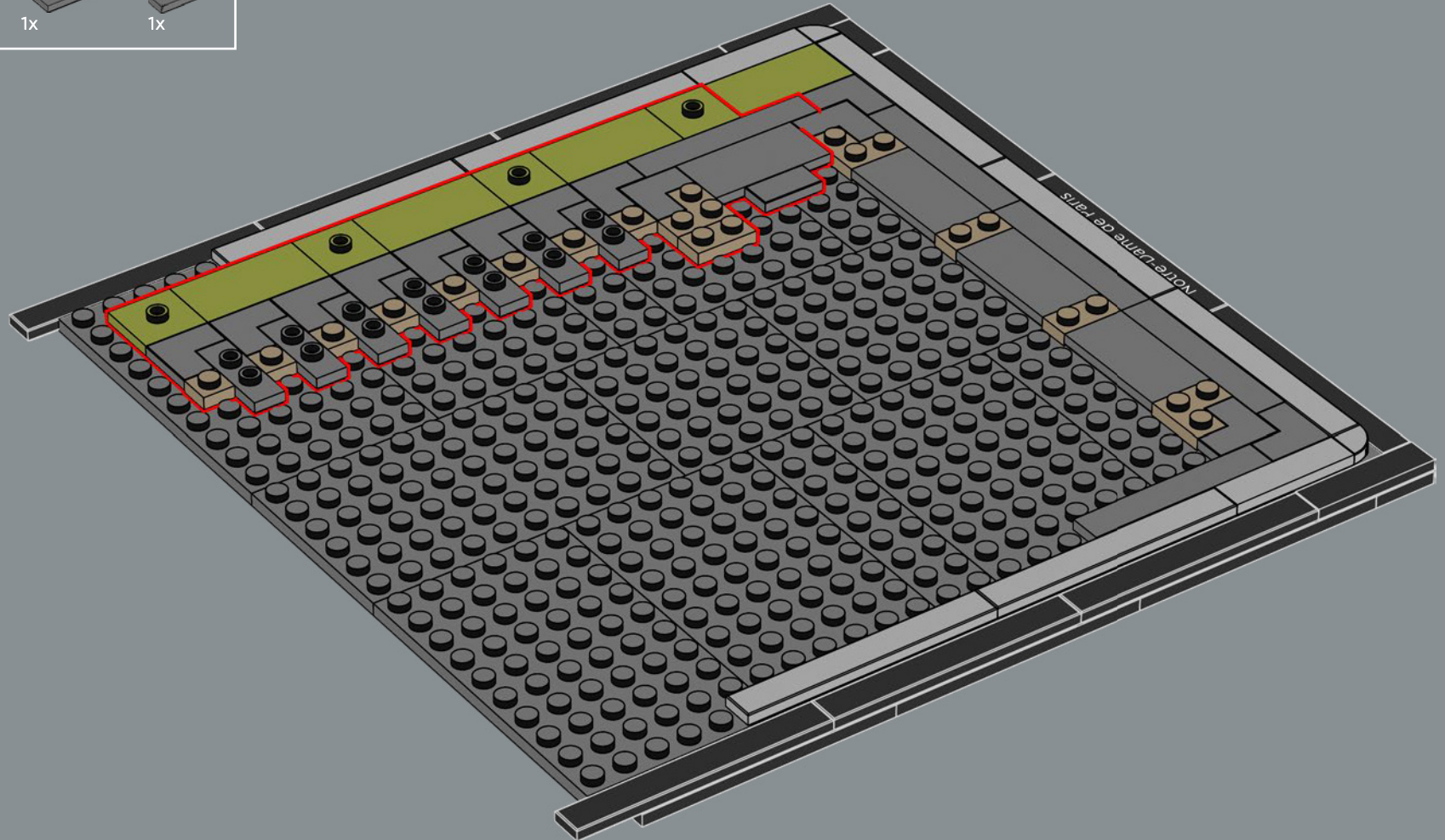

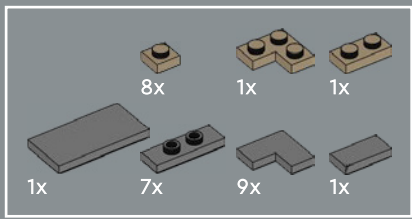

135

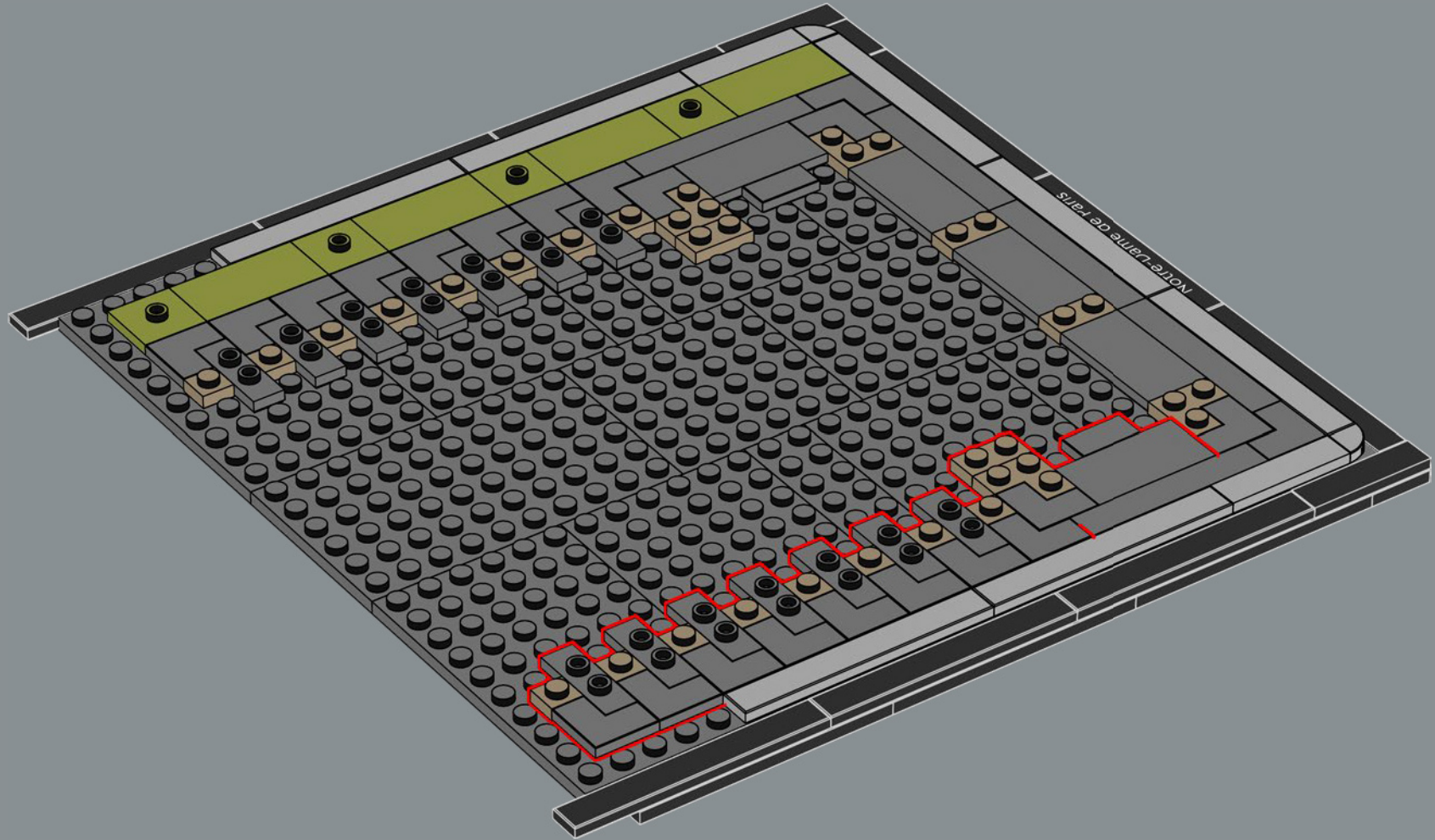

136

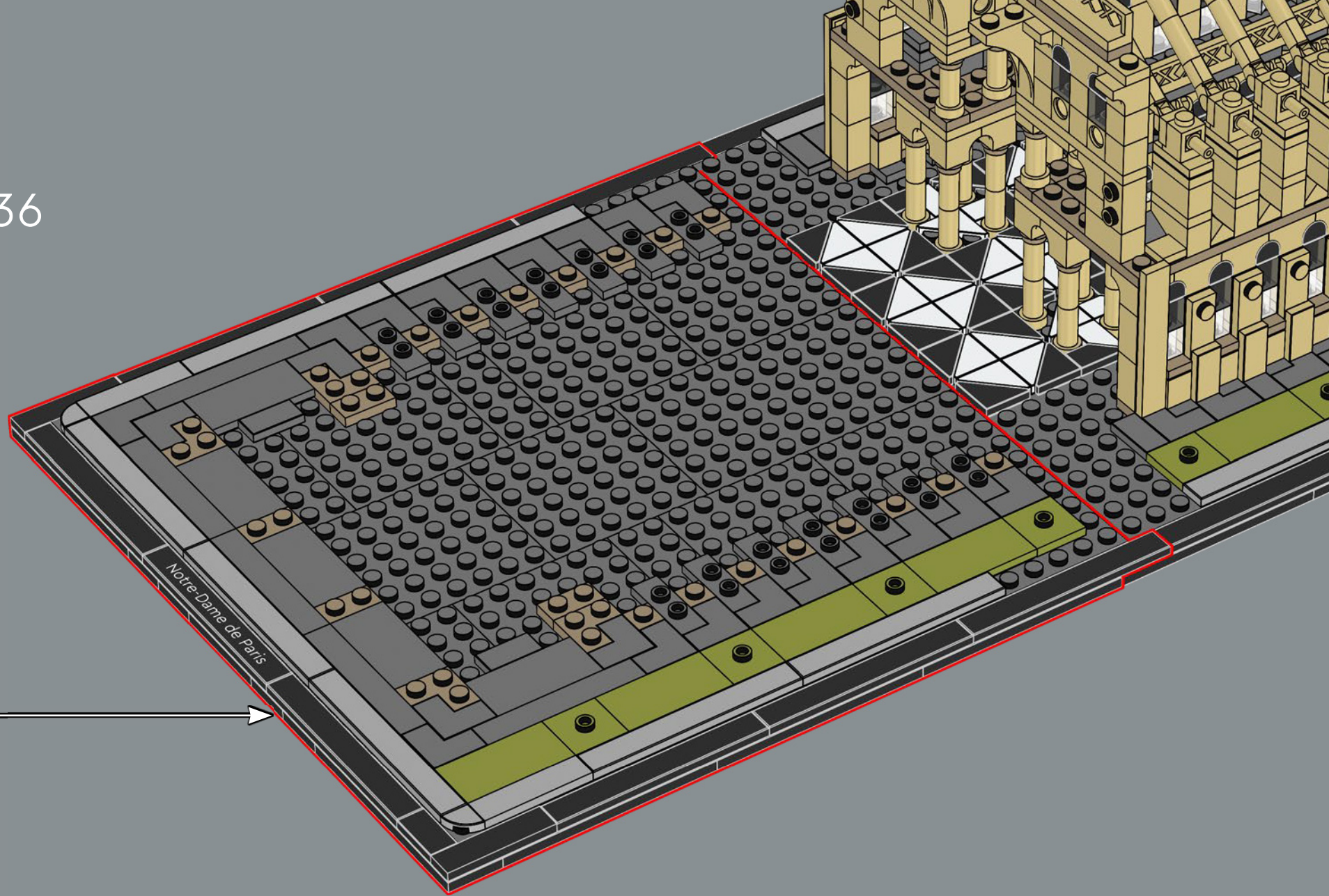

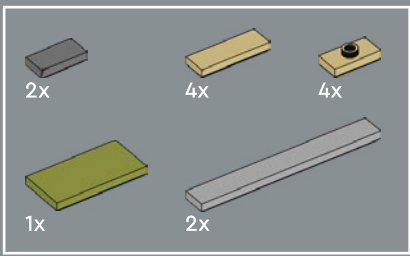

137

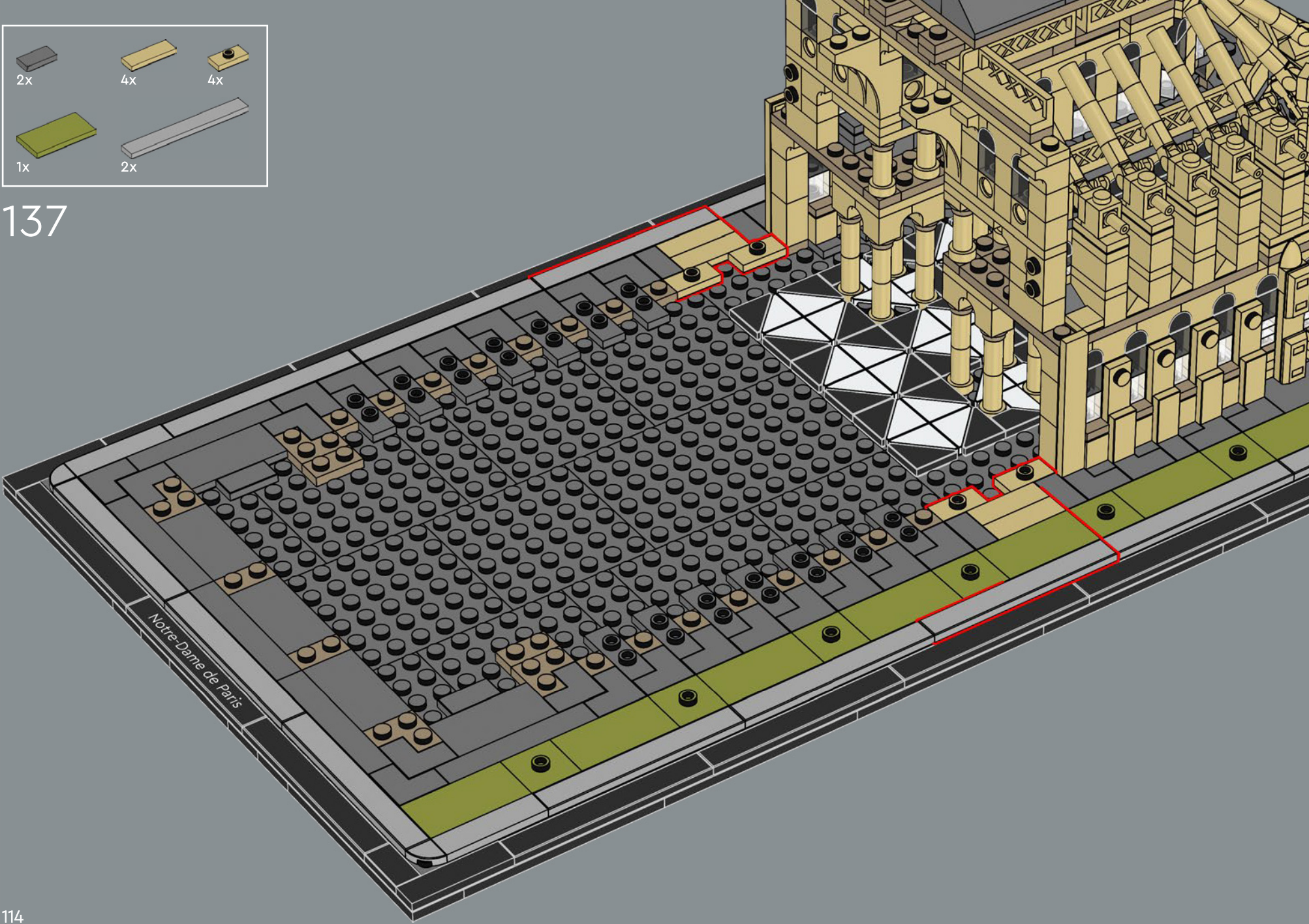

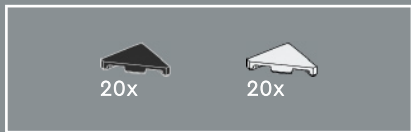

138

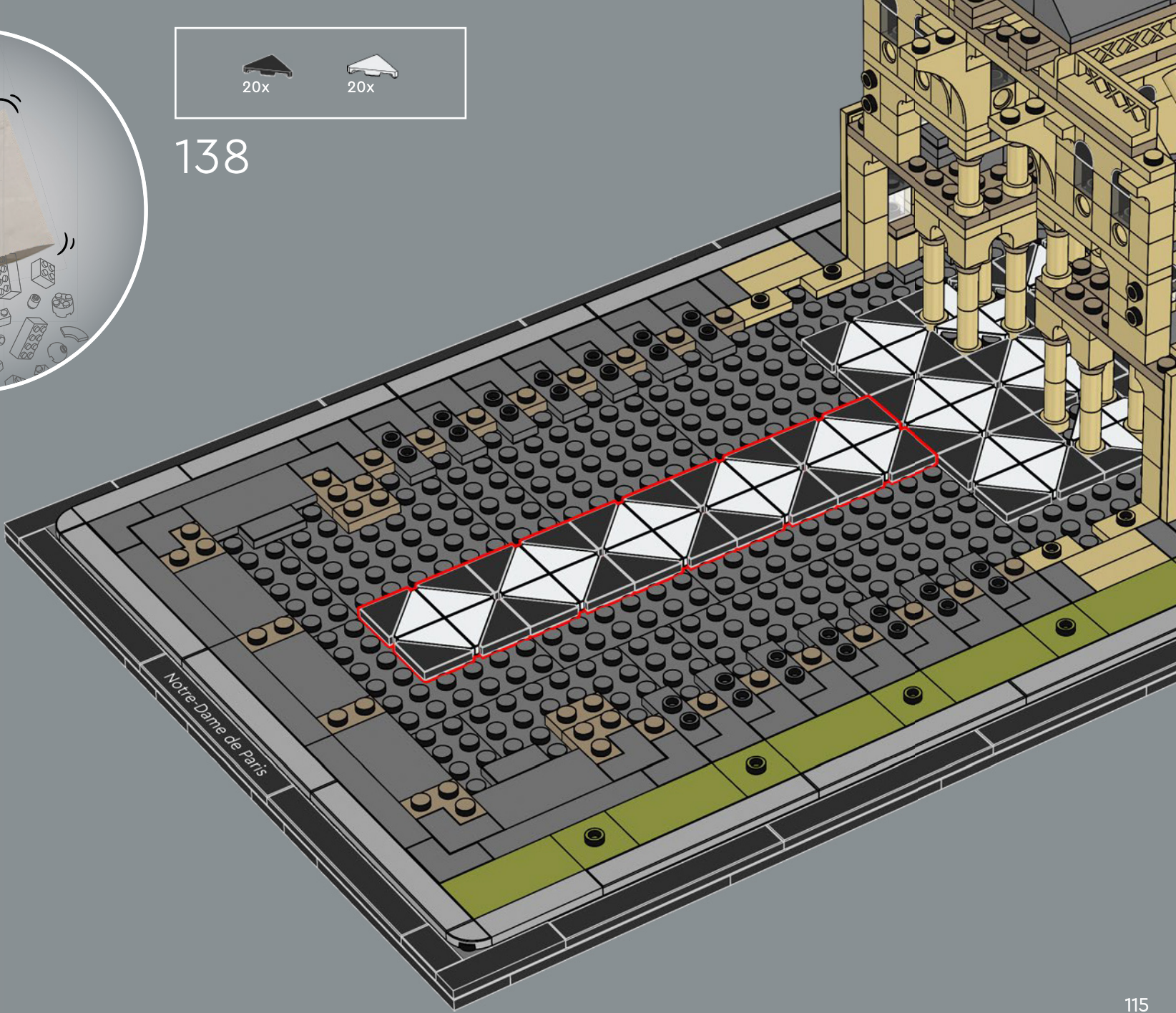

2x 30x

139

30x

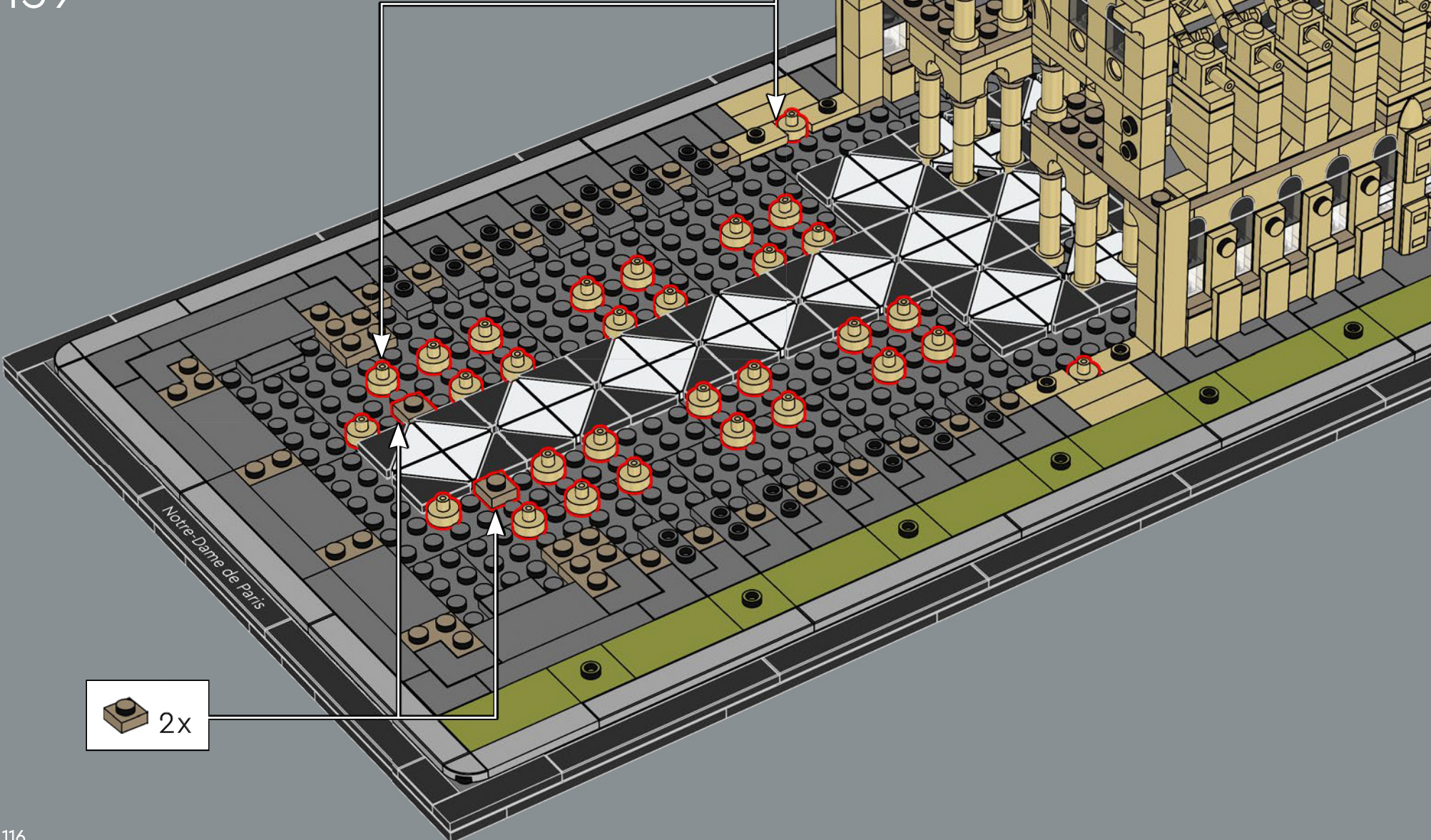

2x

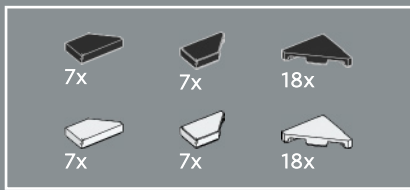

140

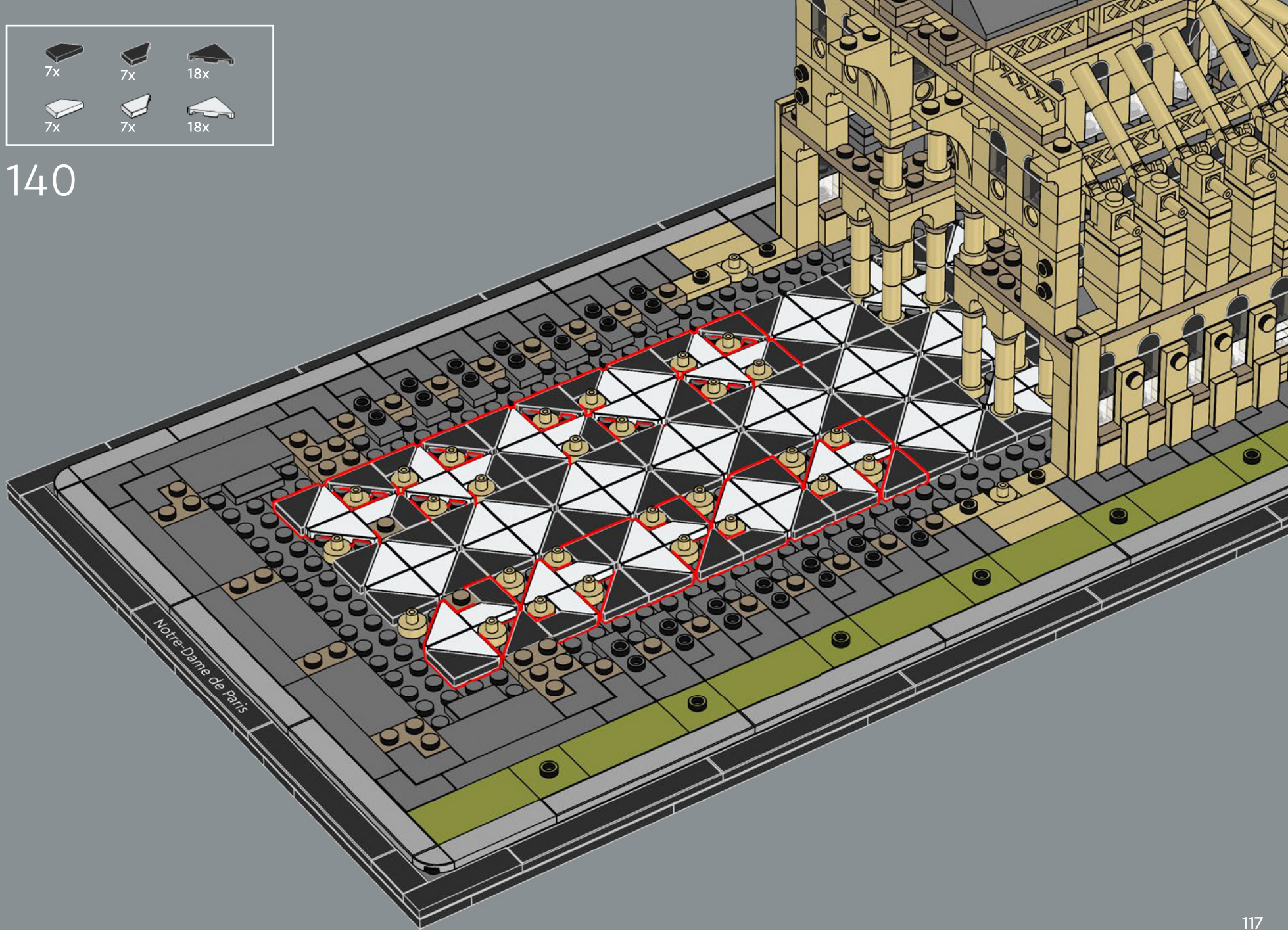



141

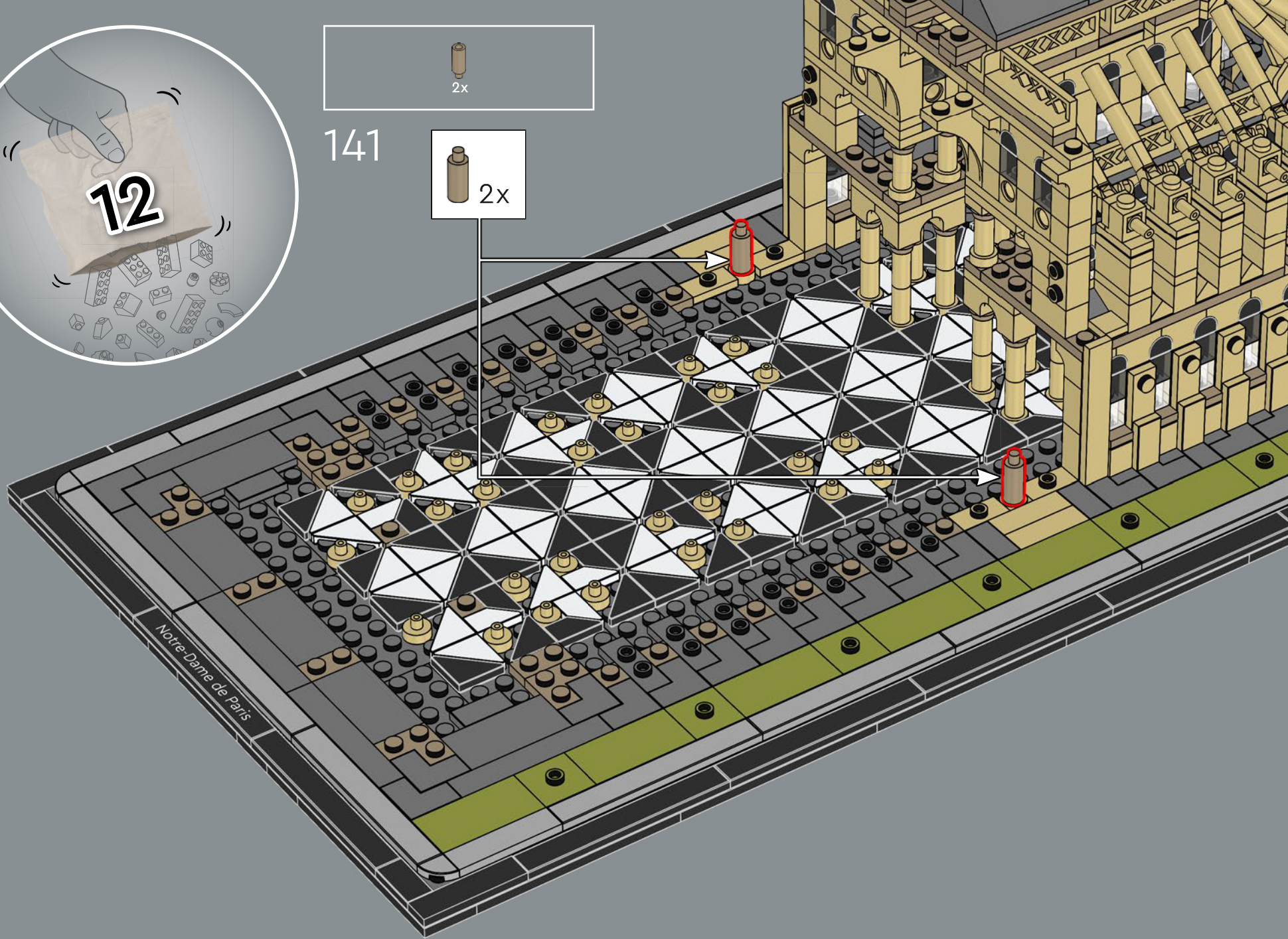
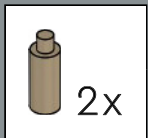

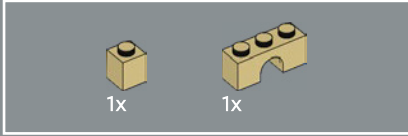
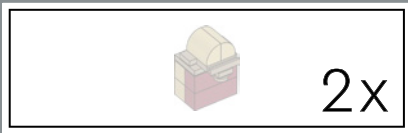

142

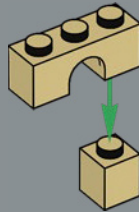

143

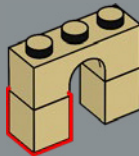

144

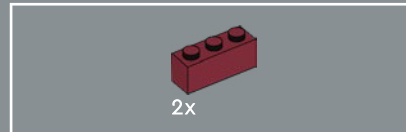
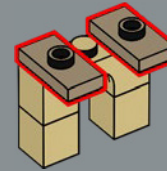

145

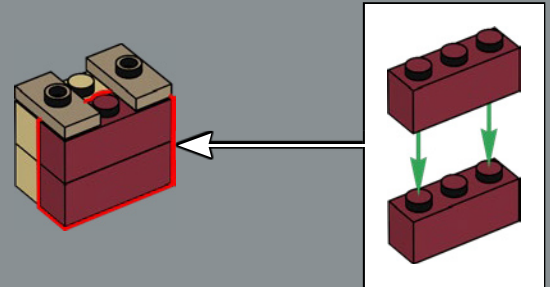

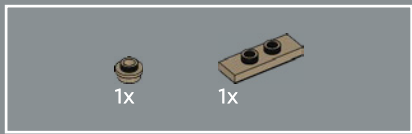

146

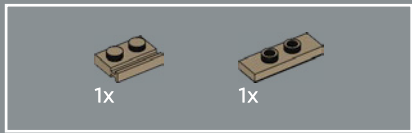
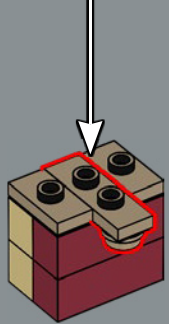
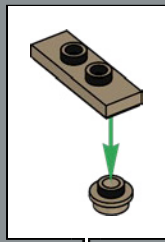

147

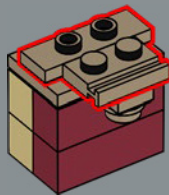

148

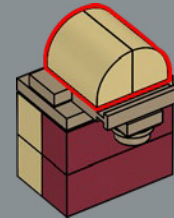

2x

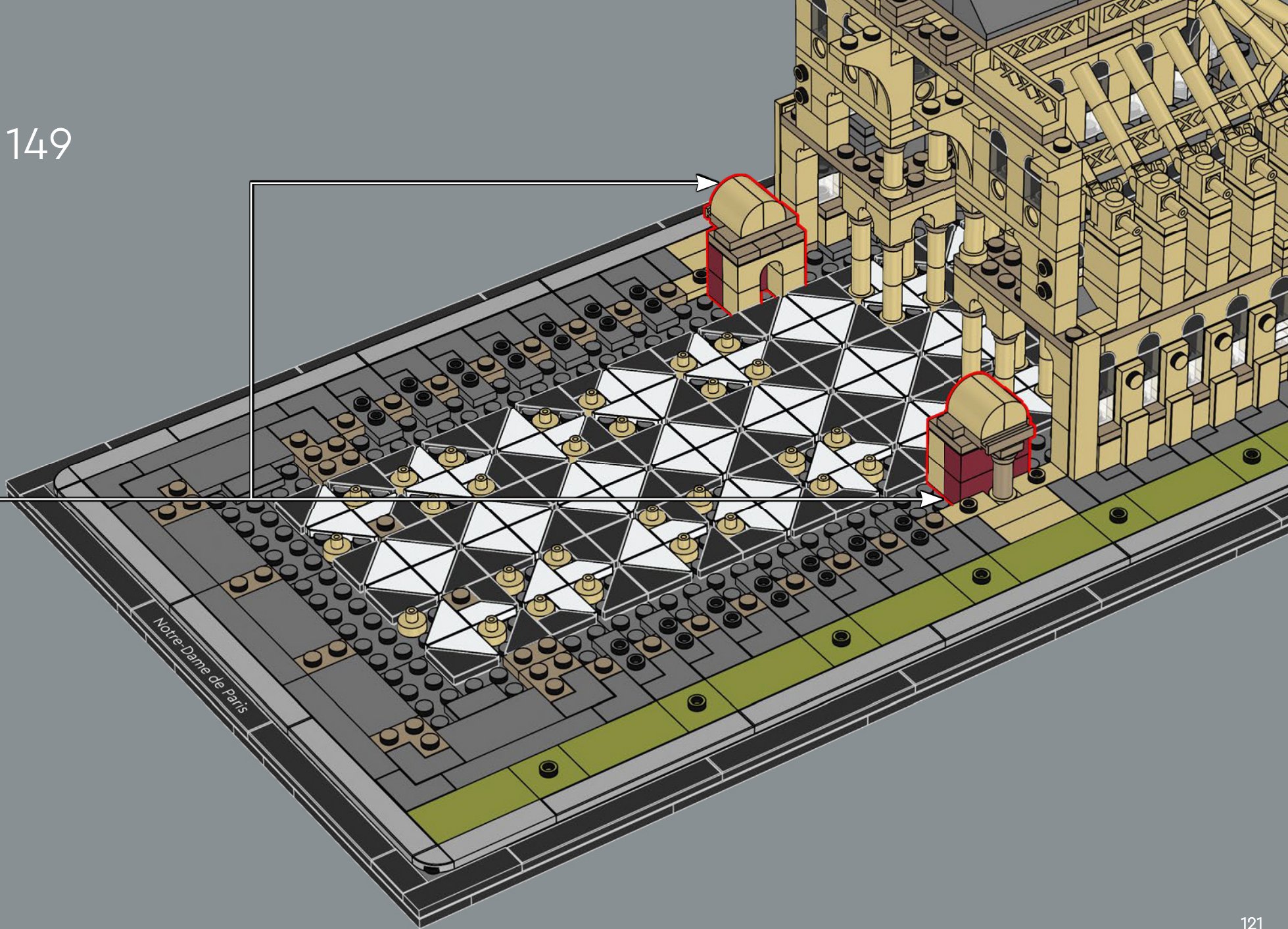

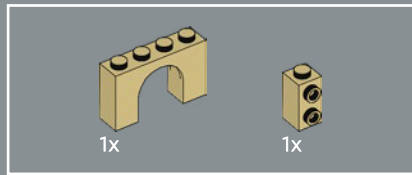
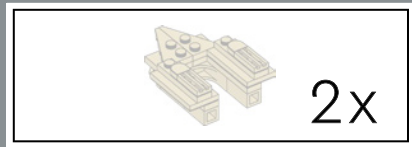

150

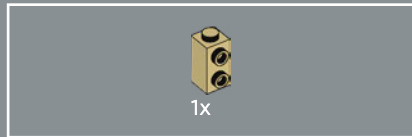
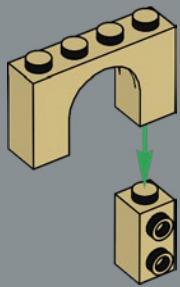

151

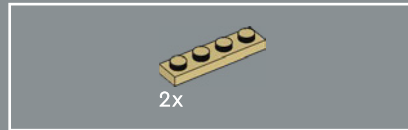
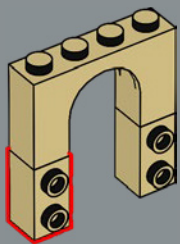

152

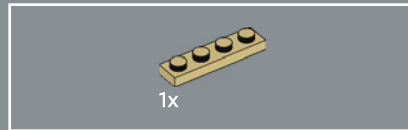
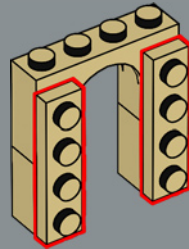

153

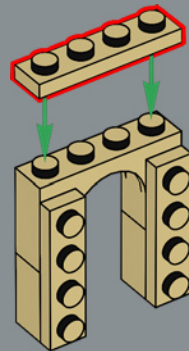

154

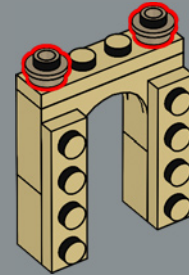

155

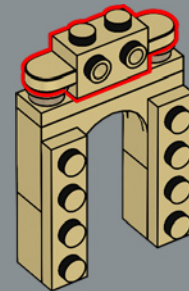

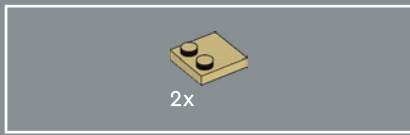

156

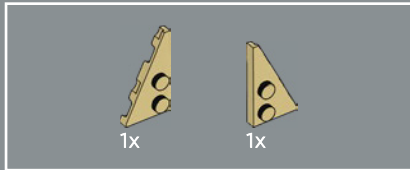
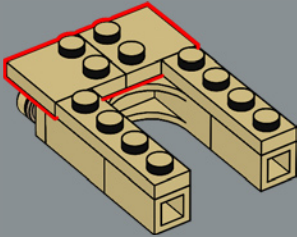

157

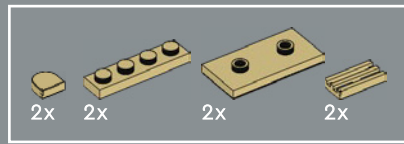
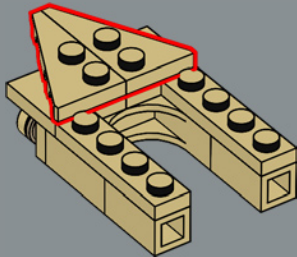

158

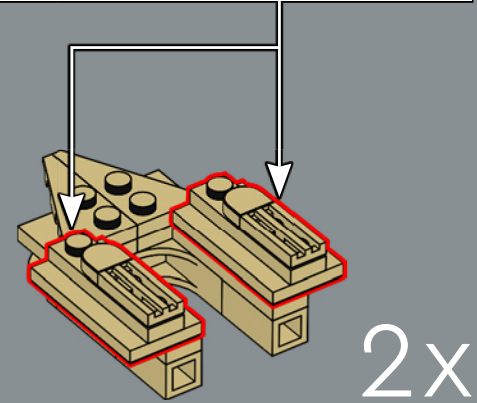
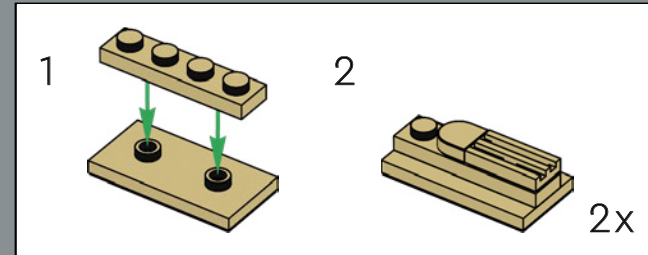

1182 - Le chœur est isolé du chantier en cours par un mur provisoire. La construction se poursuit d'est en ouest dans le transept et la nef.

159

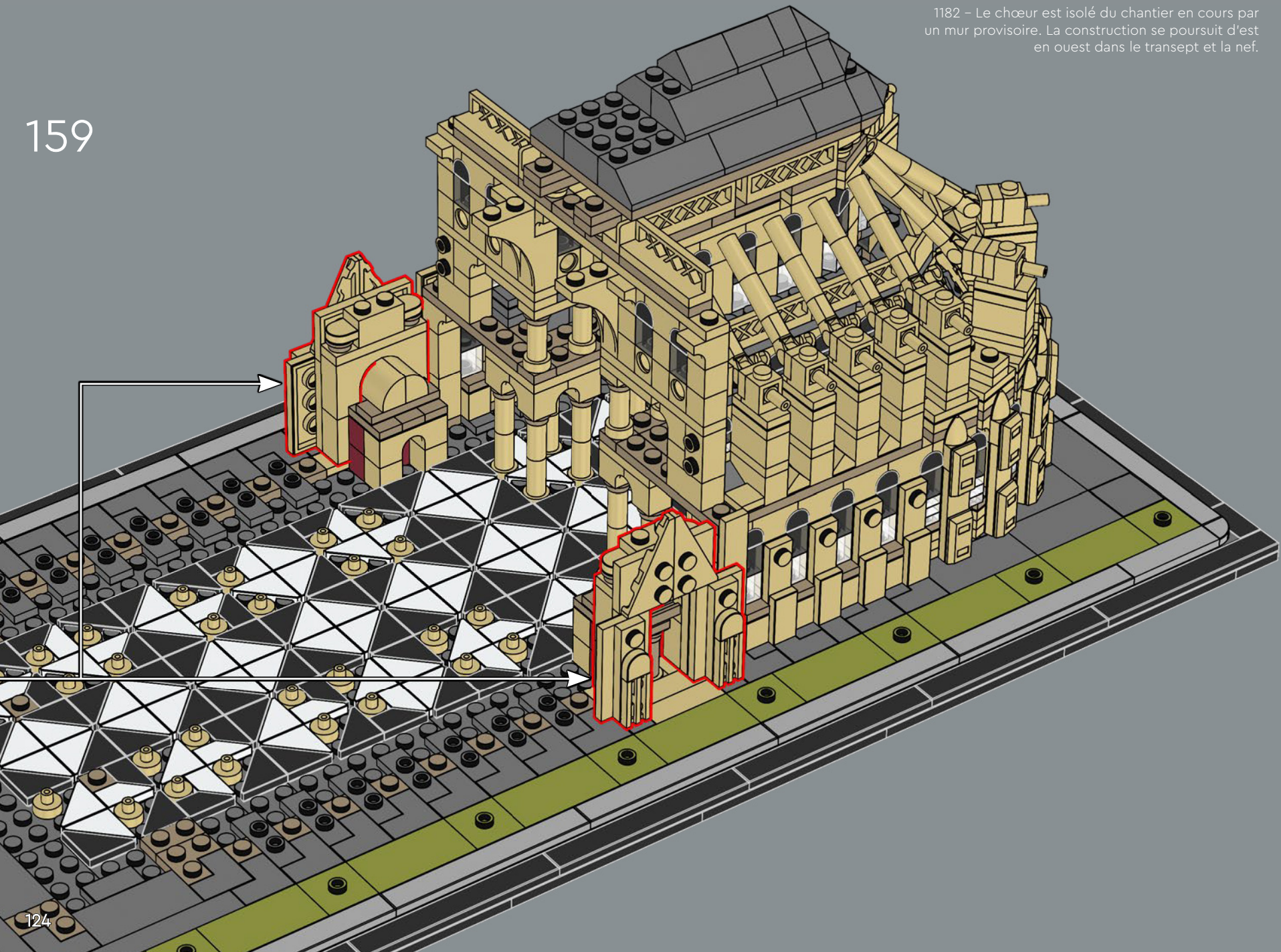

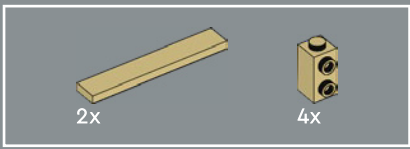

160

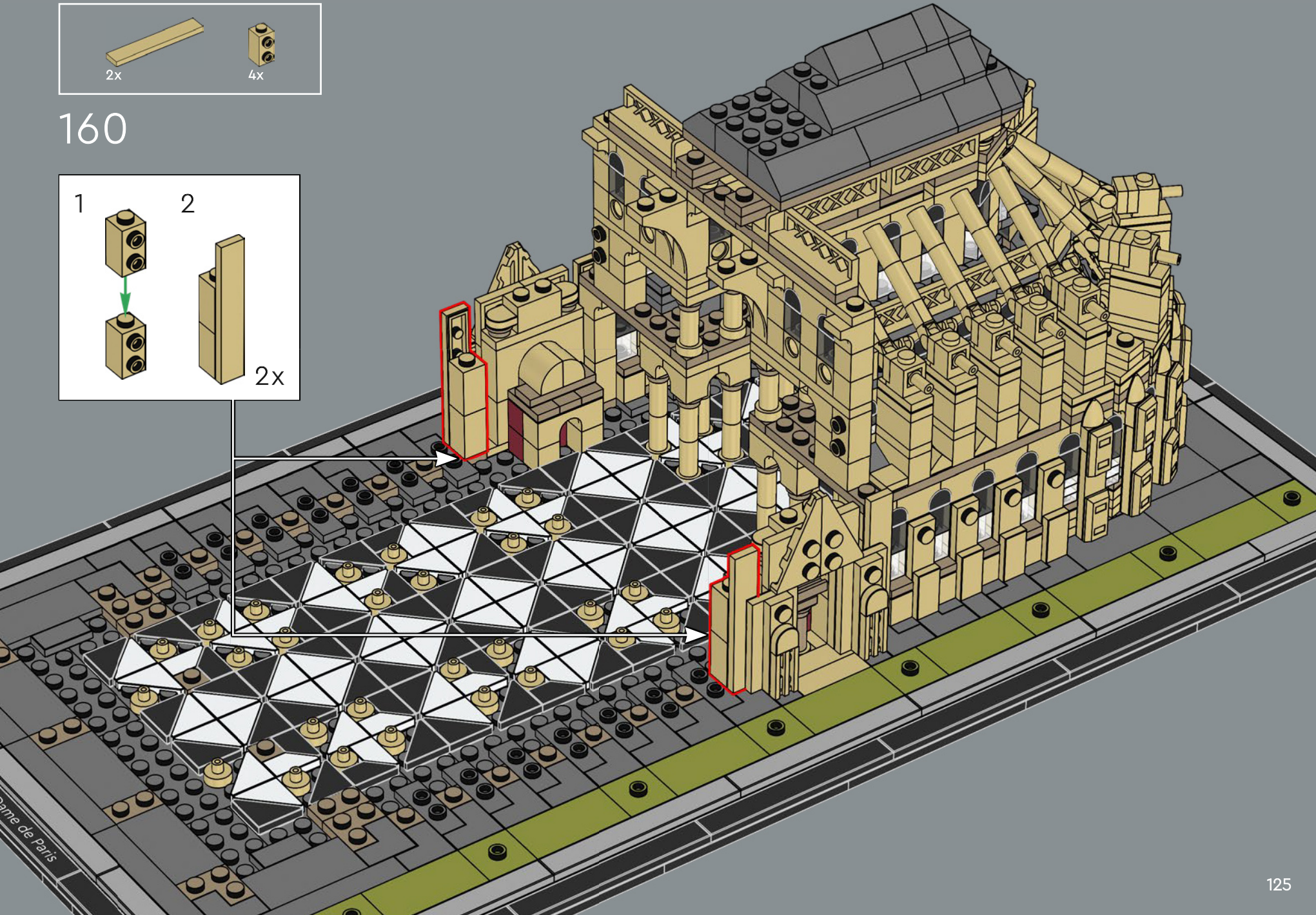
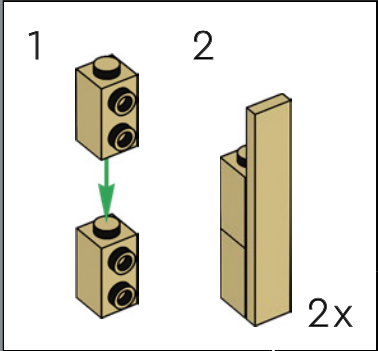

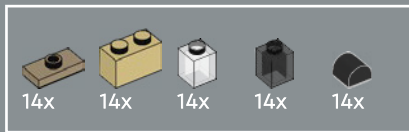

161

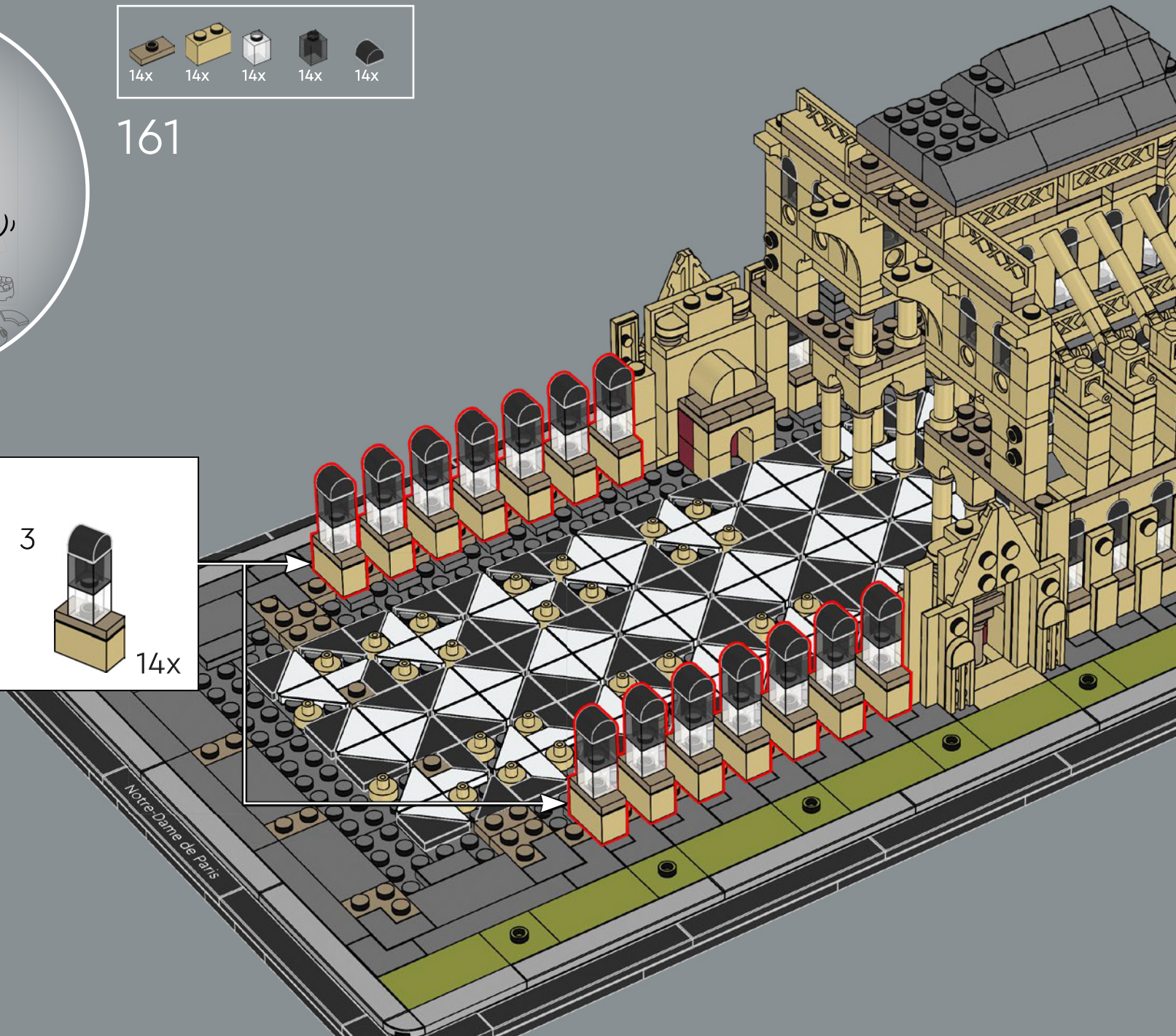
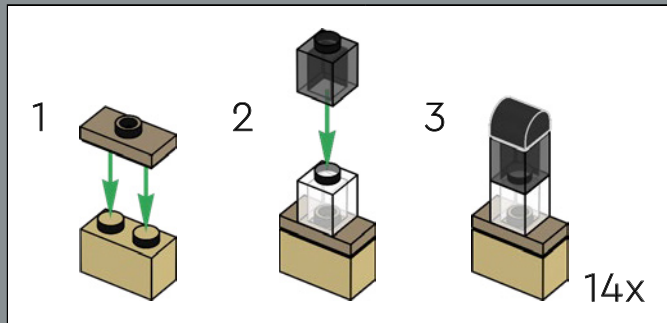

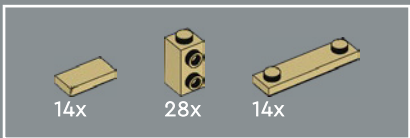

162

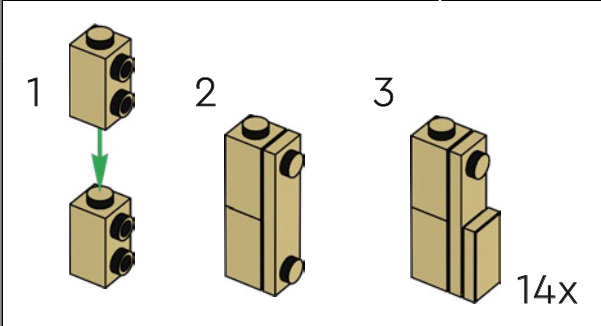
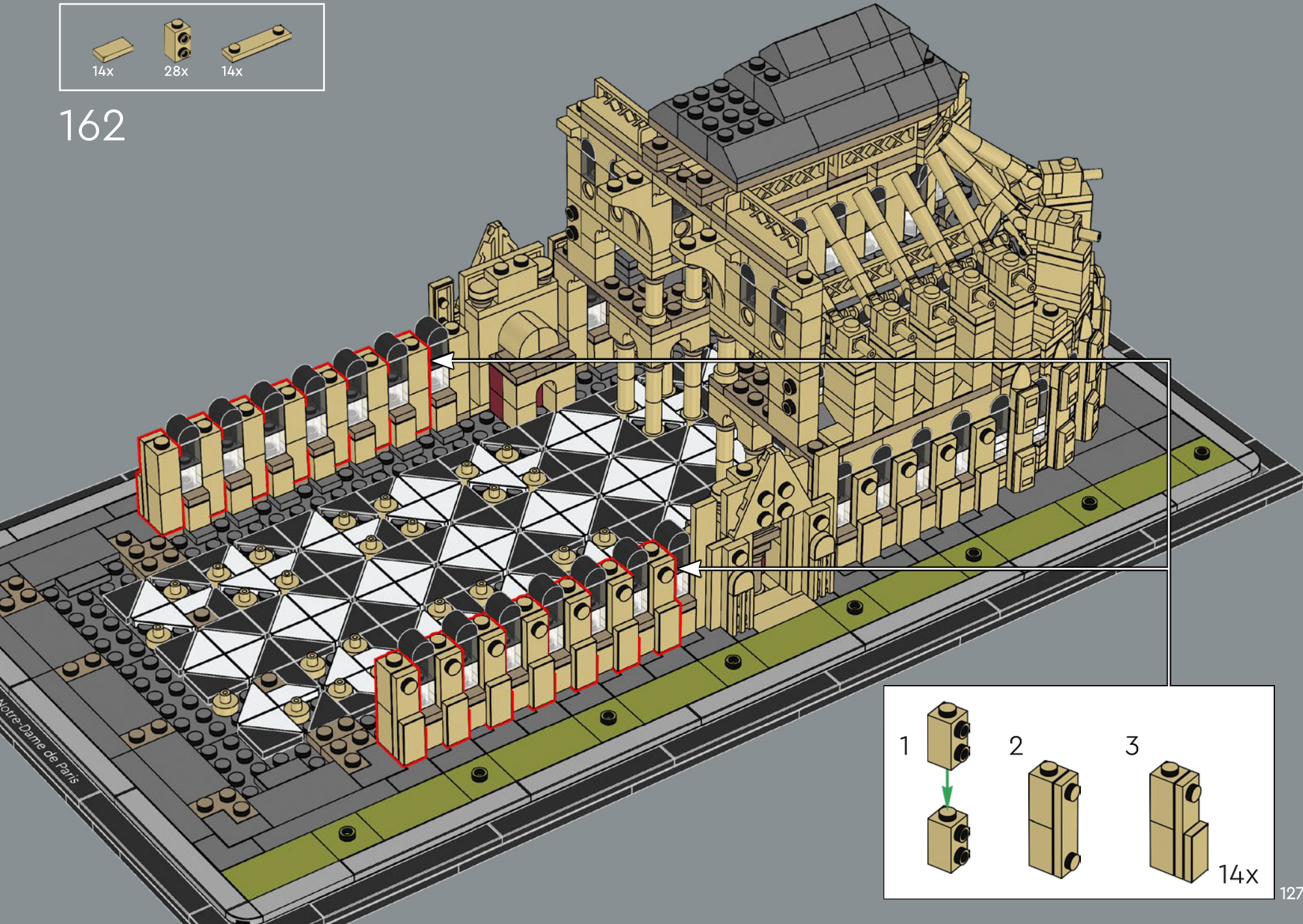



12x



4x

163



Notre-Dame de Paris



164

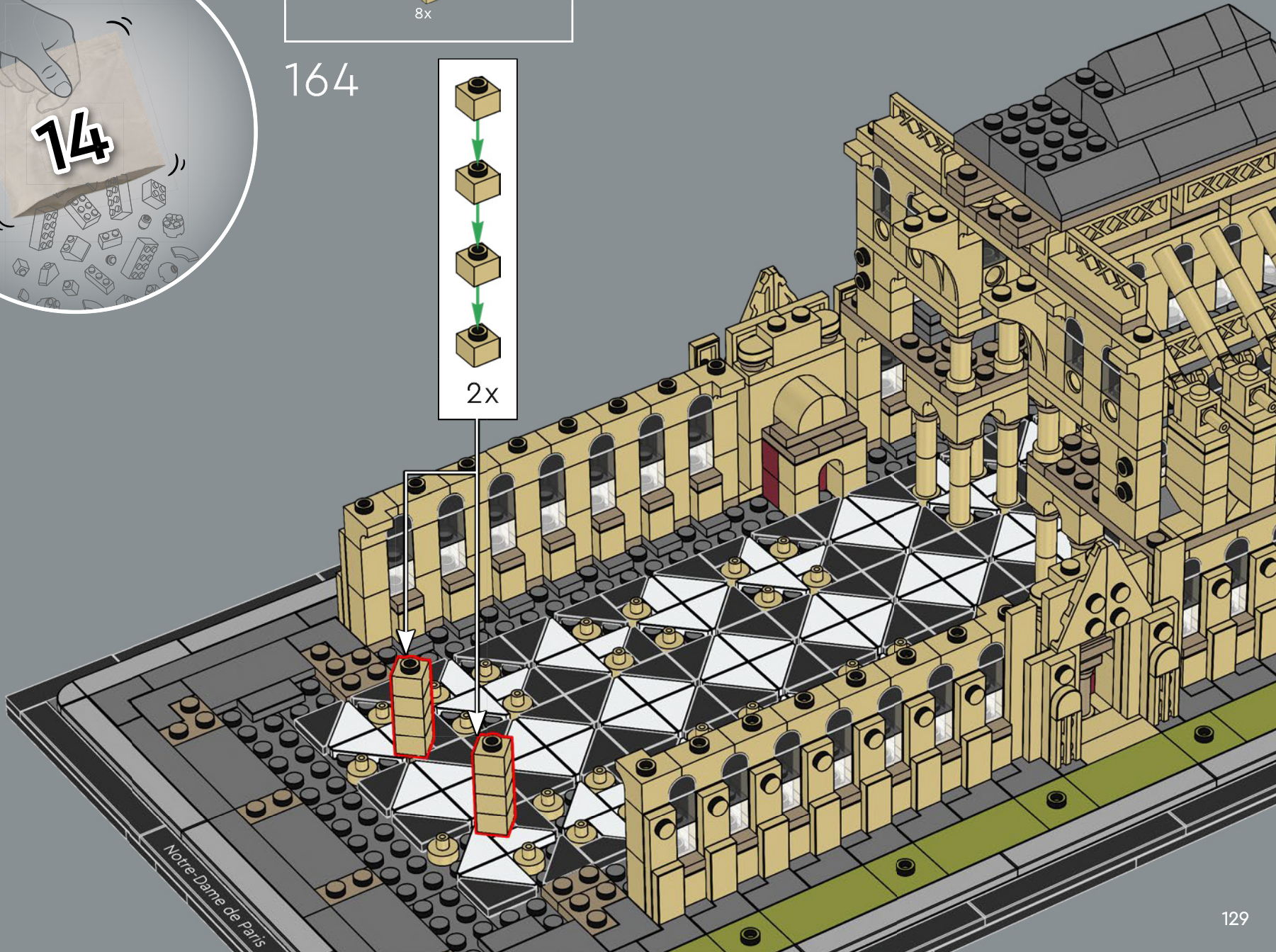
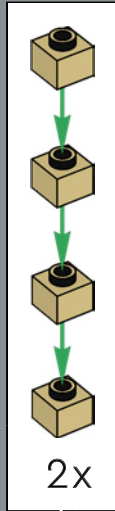



56x

165



28x

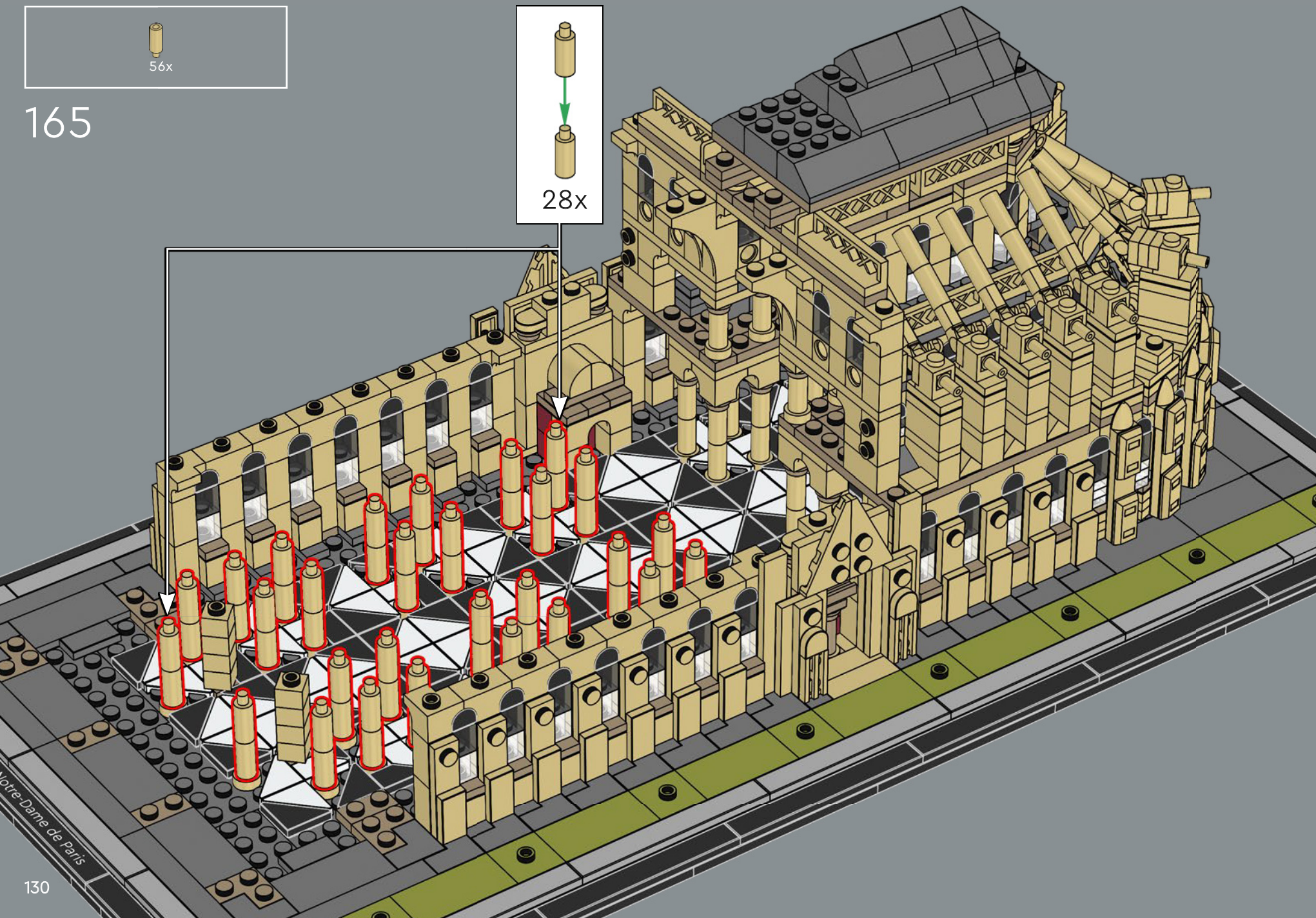

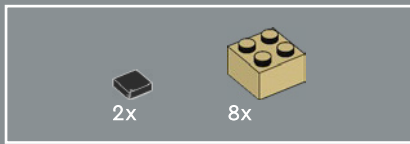

166

1208 - Les travaux se poursuivent dans la nef et les fondations des grandes tours occidentales sont posées.

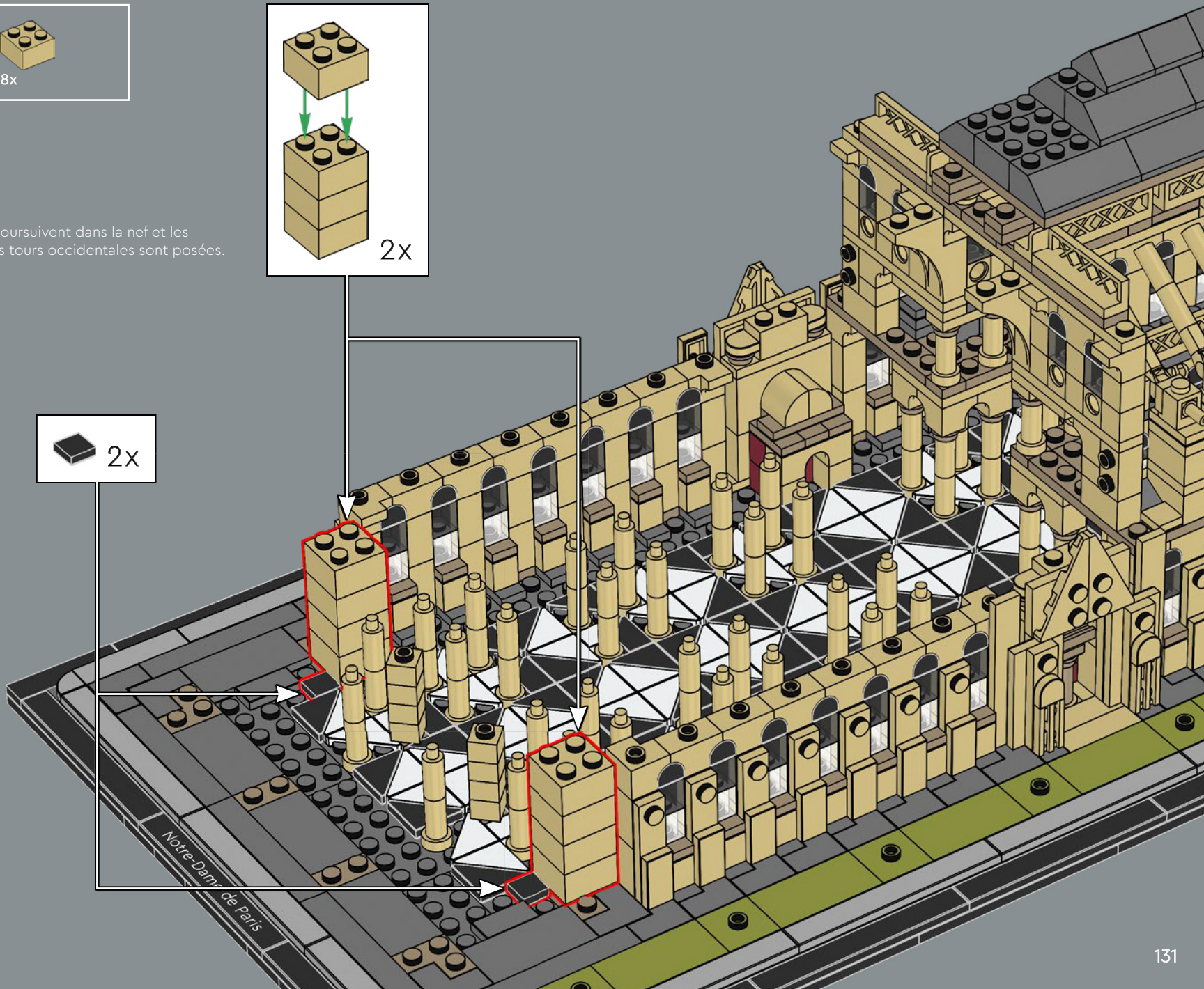
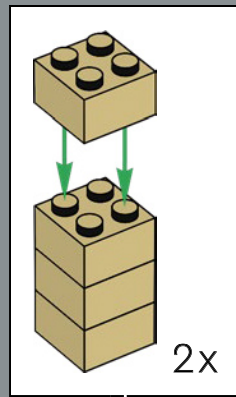

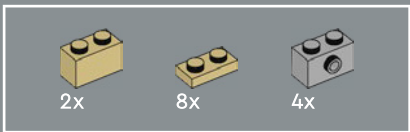

167

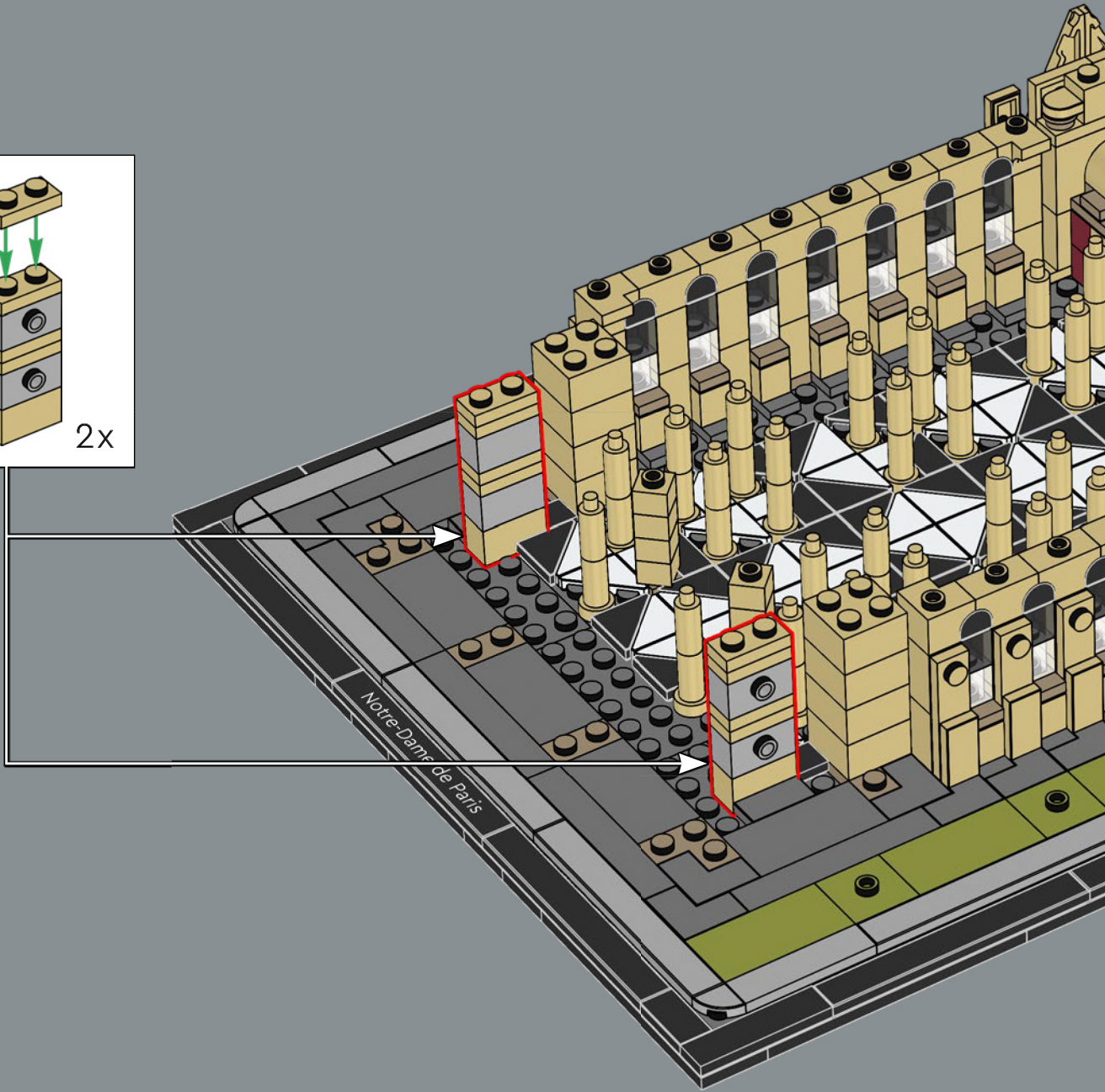
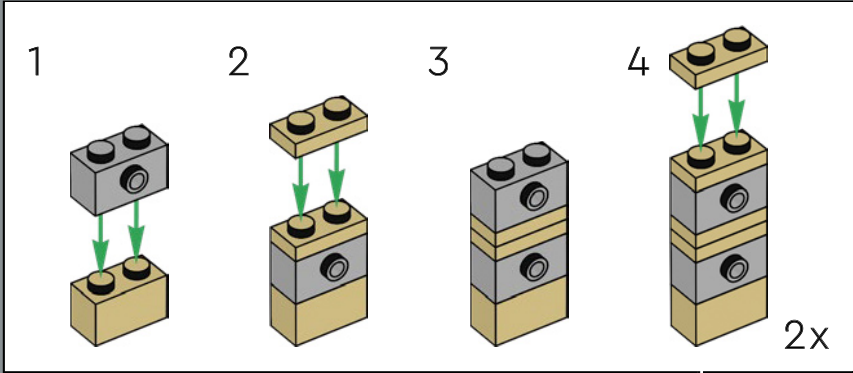

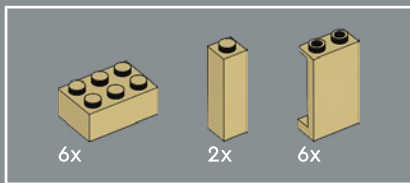

168

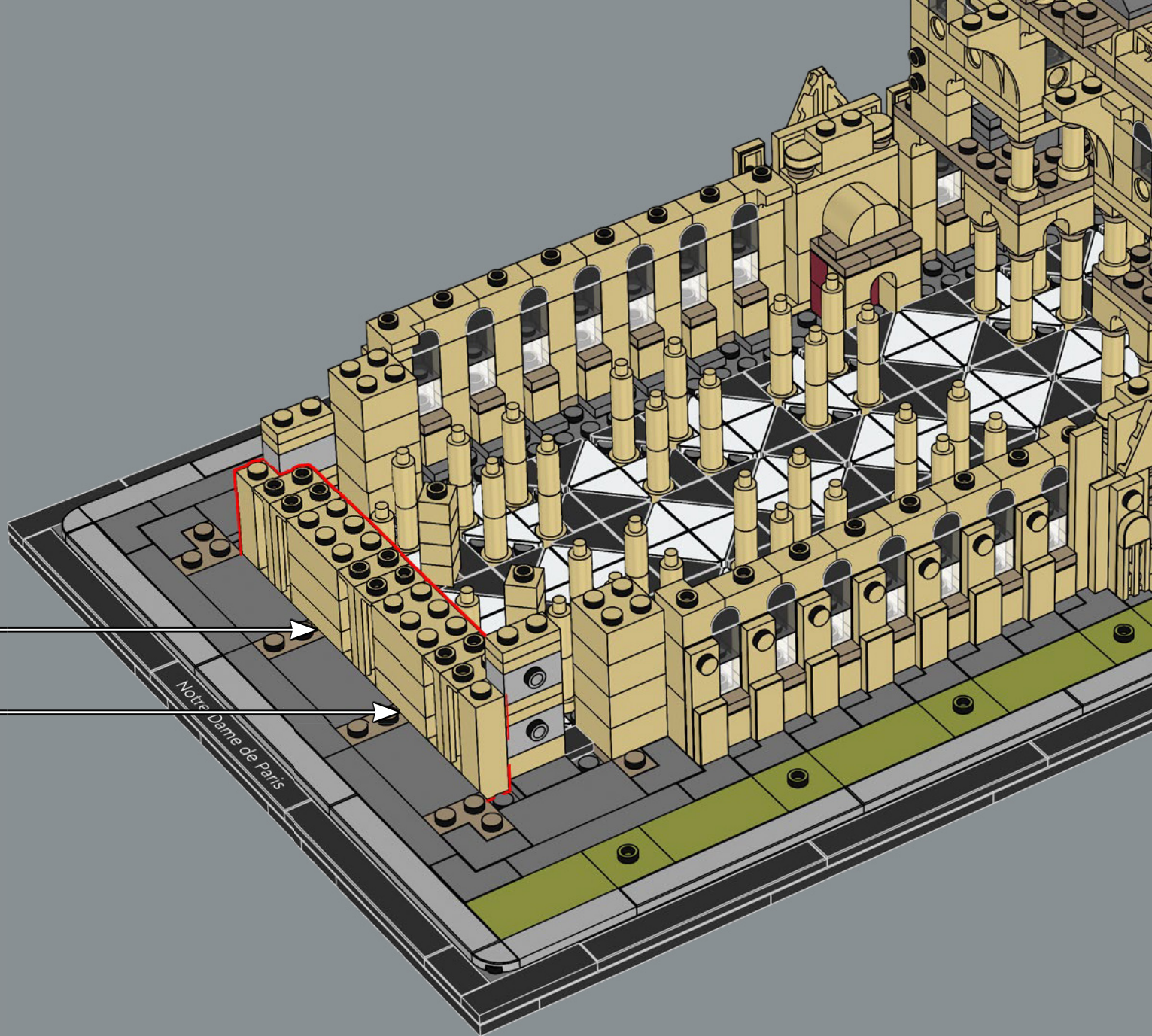
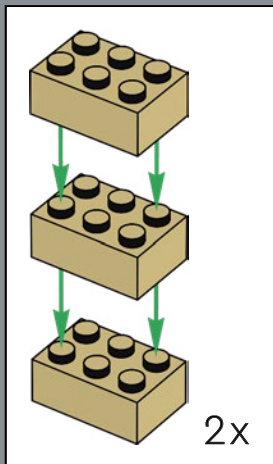

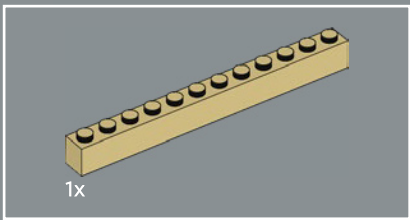

169

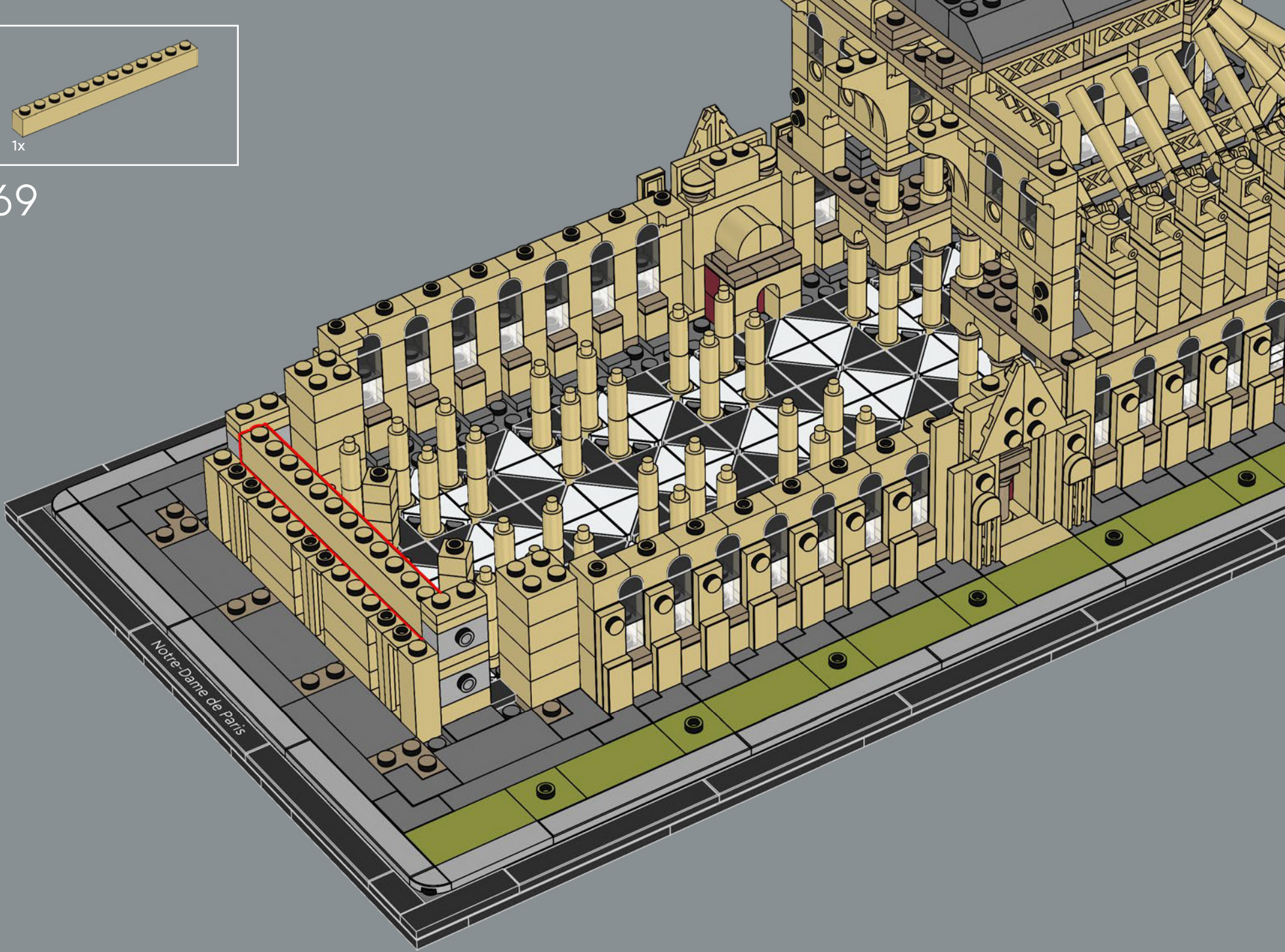

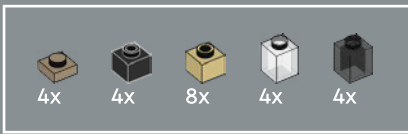

170

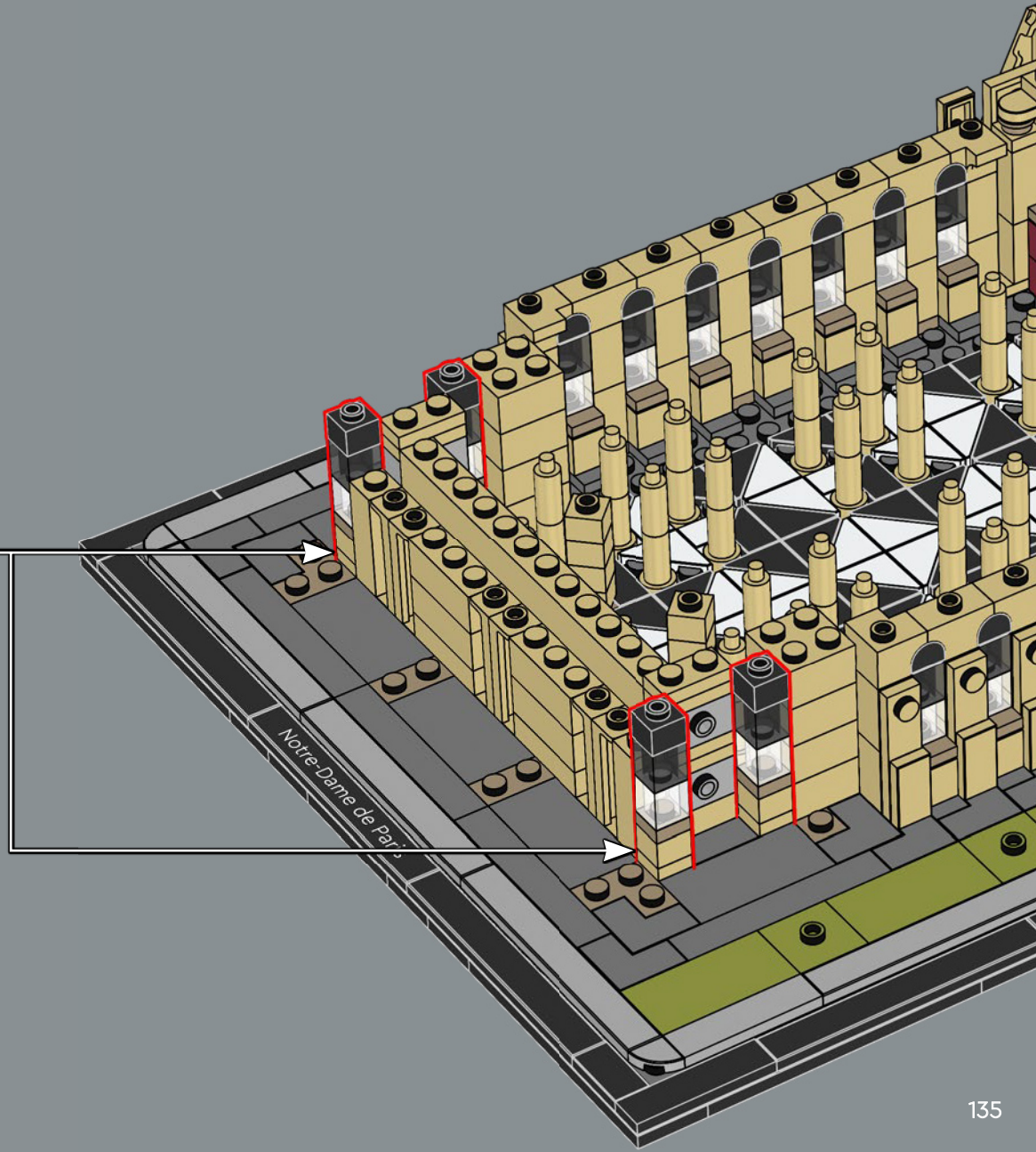
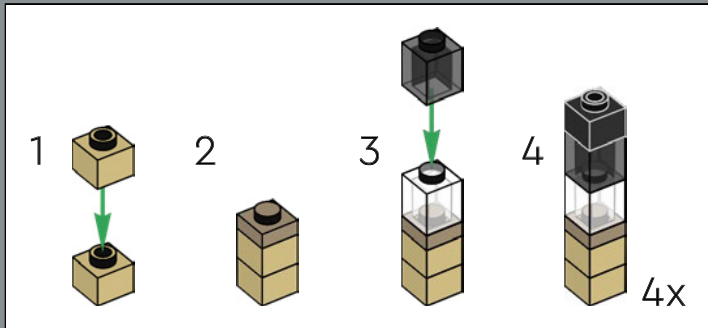

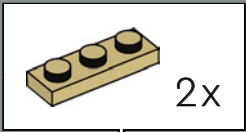
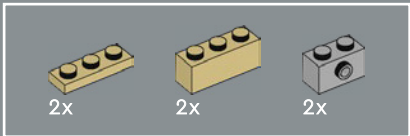

171



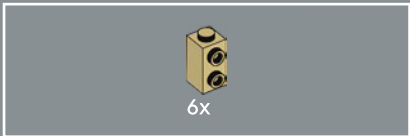

172

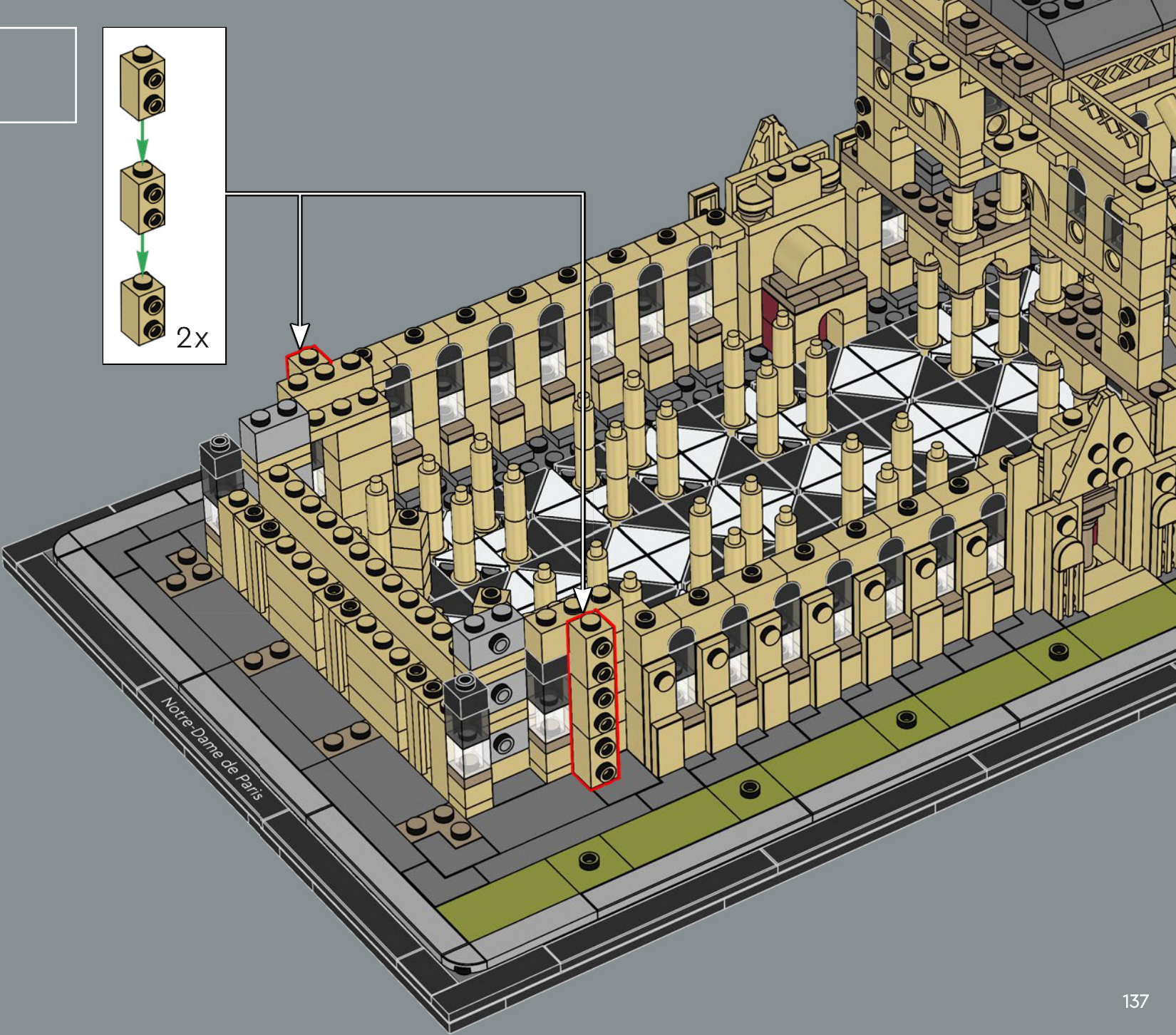
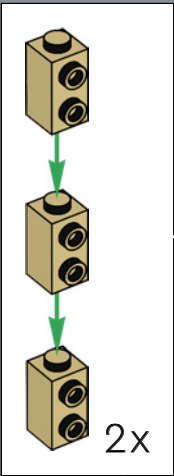

TECHNIQUES ET CARACTÉRISTIQUES DE LA CONSTRUCTION

✂ En 1208, la construction du transept est achevée. Les façades s'ornent d'impressionnantes rosaces uniques, toutes de tailles différentes, et composées de motifs variés. Au nord, la rosace d'origine atteint un diamètre de 13,5 m, un record pour l'époque. Chaque élément architectural de la cathédrale sert un objectif précis, à la fois décoratif et pratique. Les trois rosaces LEGO® sont une représentation abstraite des vitraux originaux : elles possèdent toutes la même taille et les mêmes motifs, et peuvent être positionnées de façon interchangeable dans le modèle. En 1220, le corps de la cathédrale est achevé, à l'exception de la partie supérieure des tours.

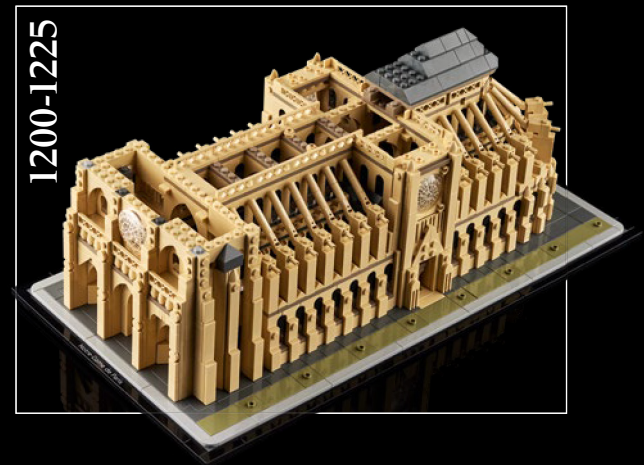

En évacuant les eaux pluviales, les gargouilles caractéristiques permettent également de protéger la cathédrale des dommages causés par un ruissellement excessif. Ces caractéristiques sont restituées dans votre modèle.



173

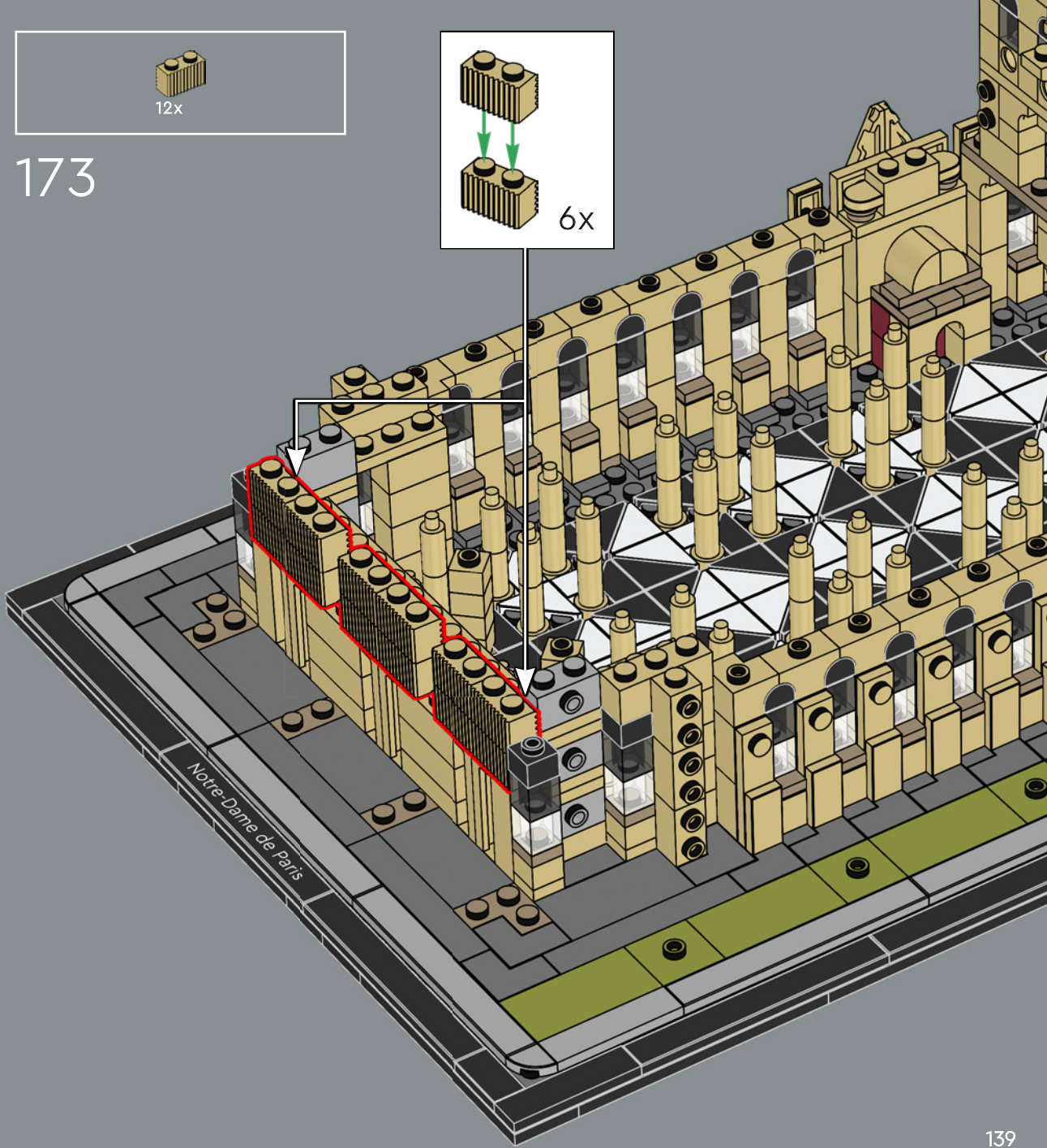
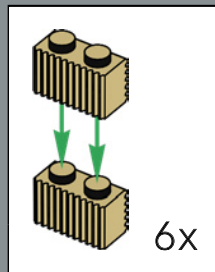

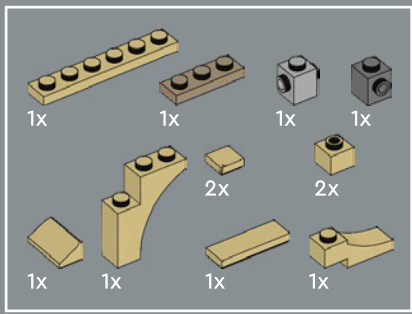

174

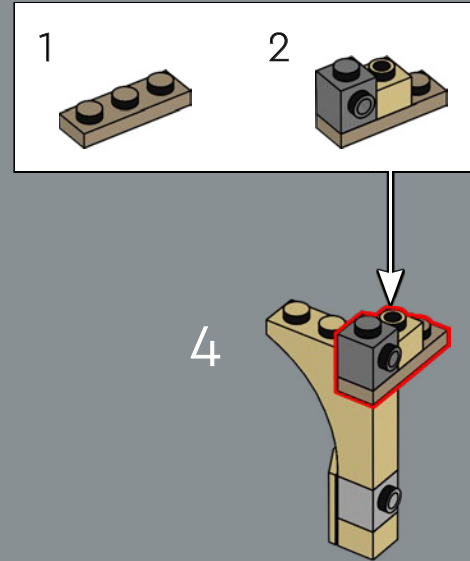
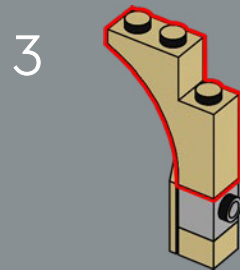
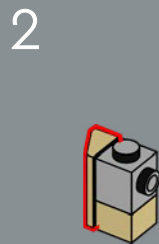
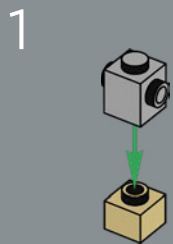

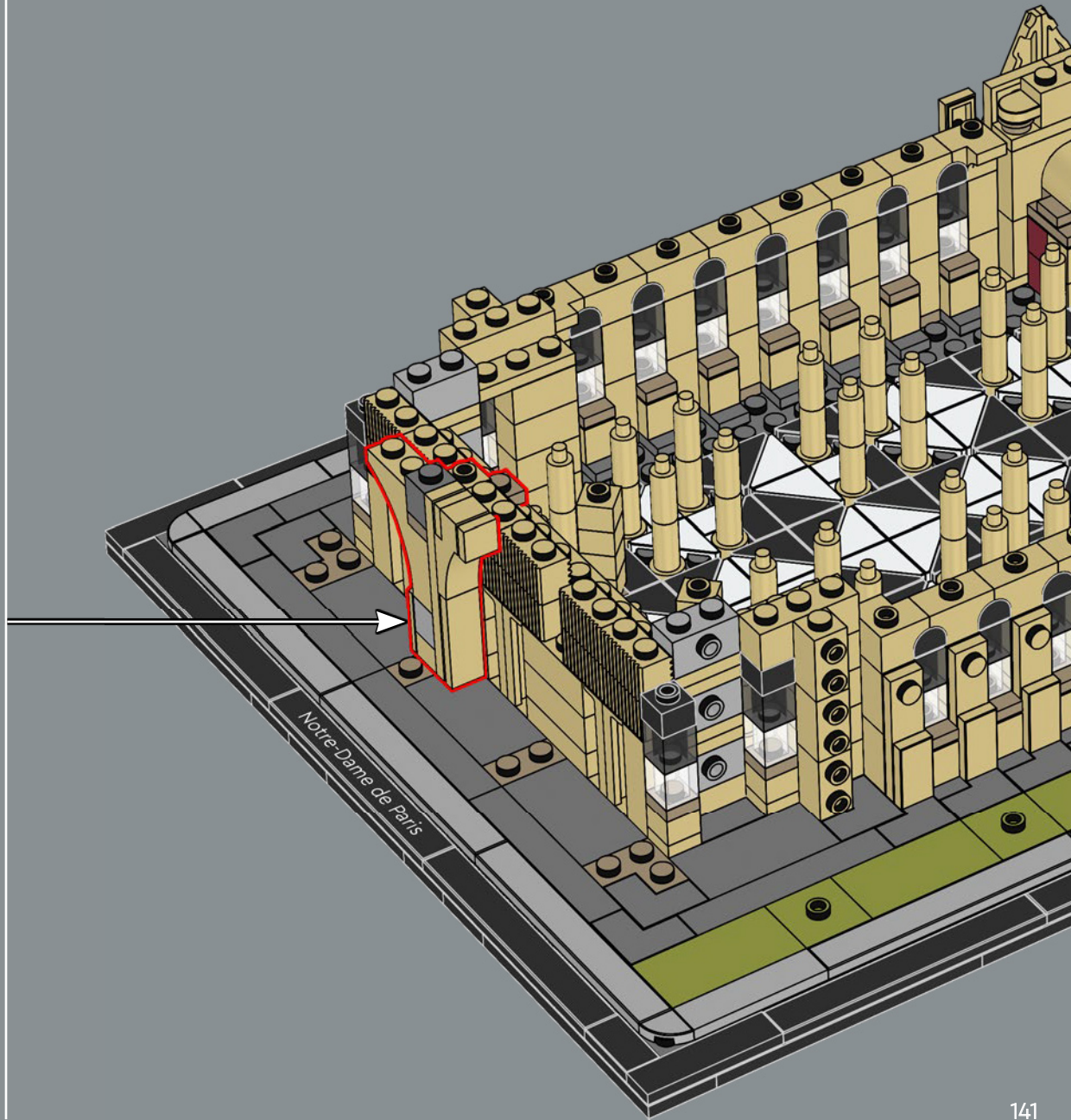
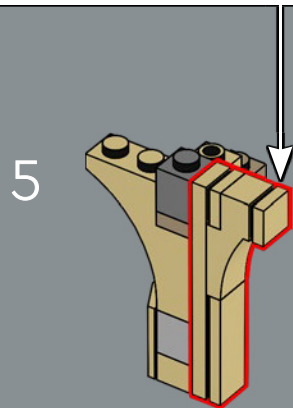
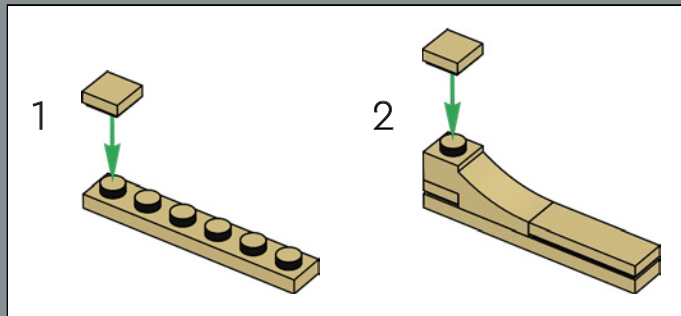

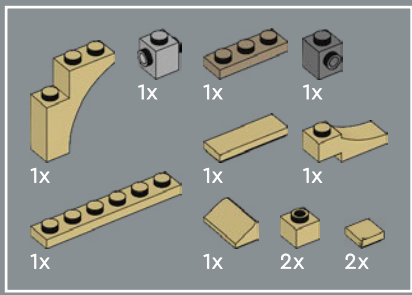

175

1

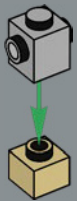

2



3

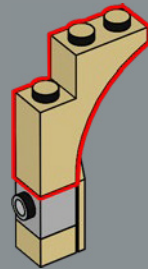

1

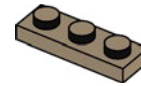

2

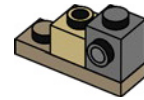

4

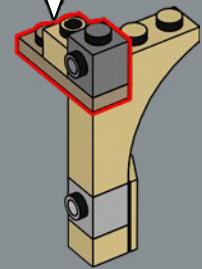

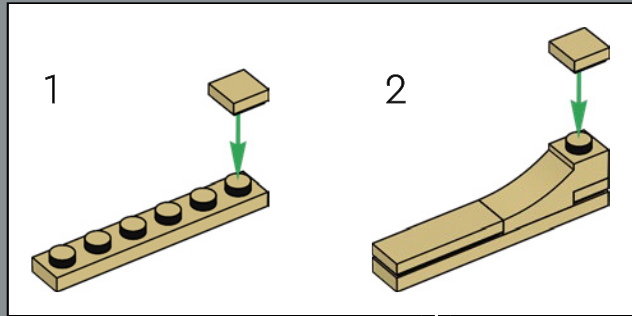

5

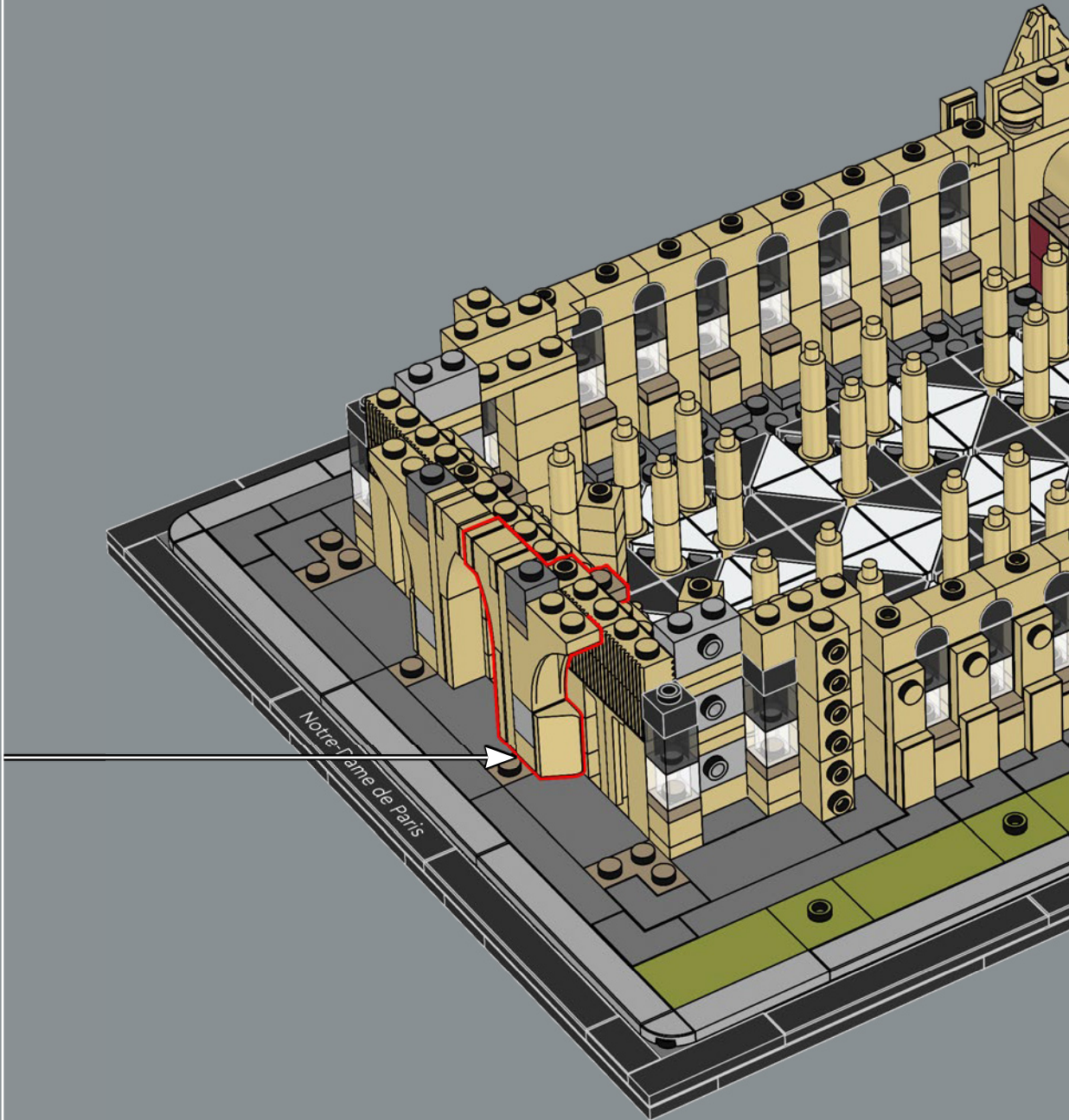
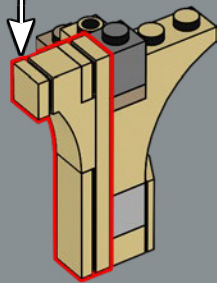

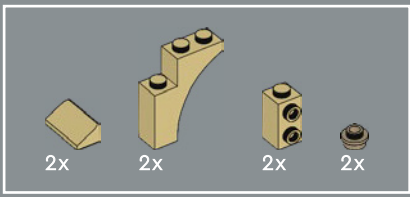

176

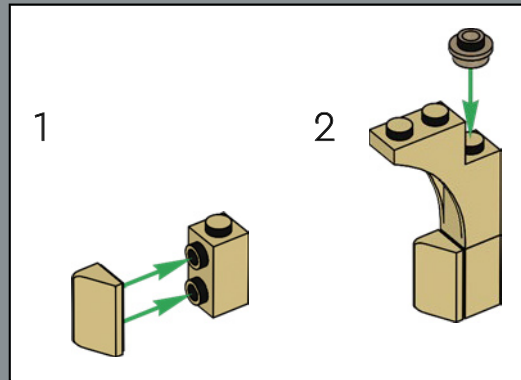
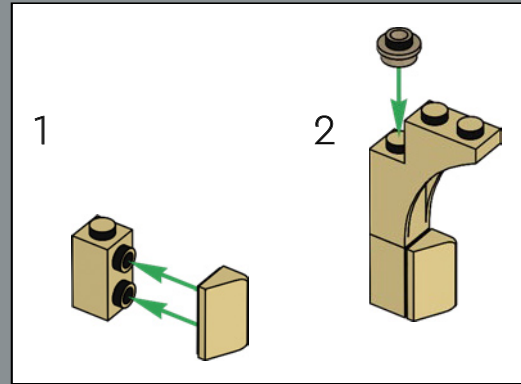

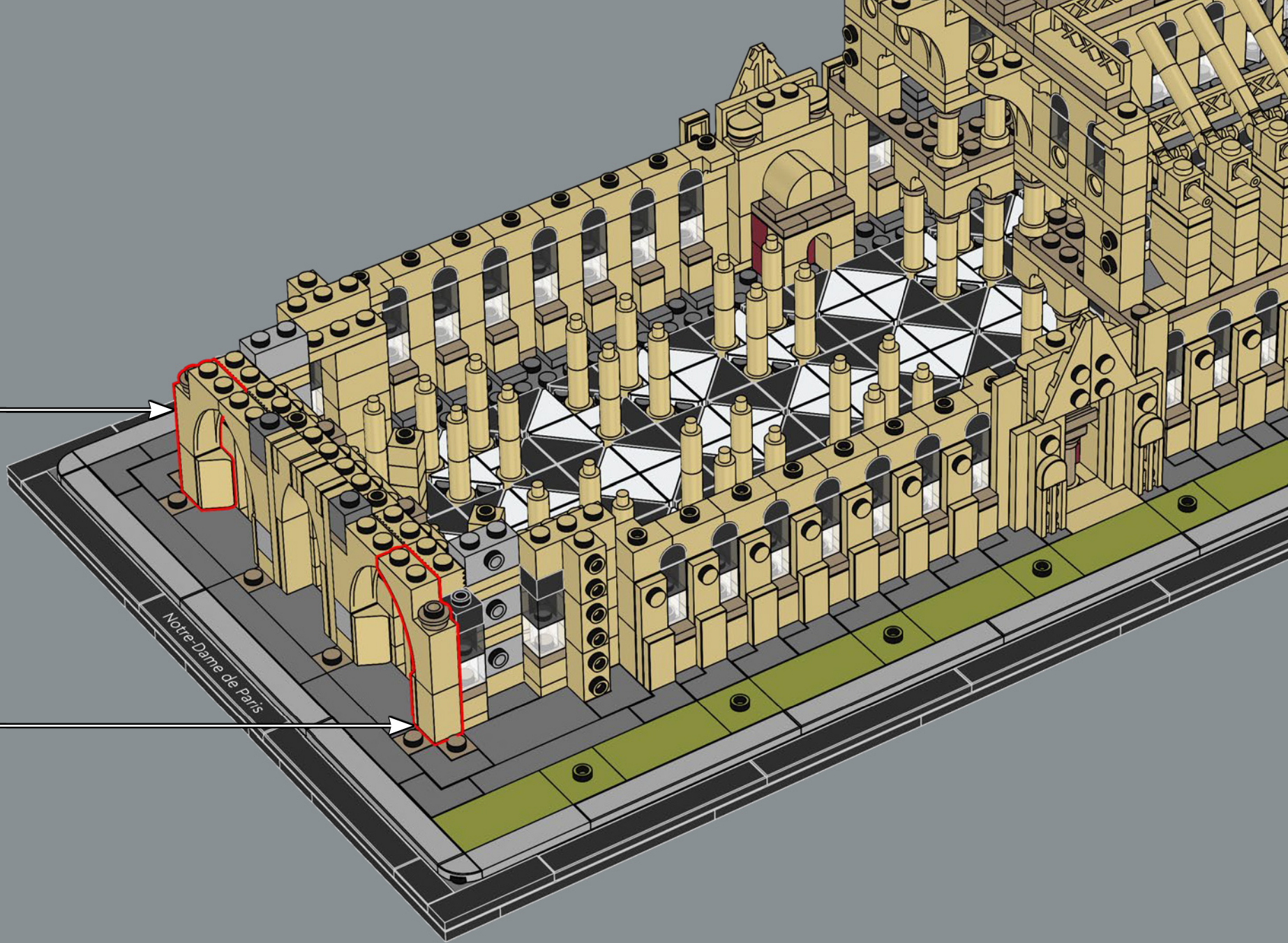

Notre-Dame de Paris

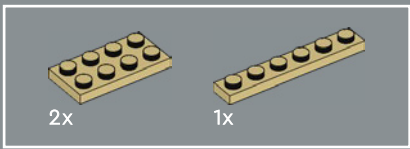

177



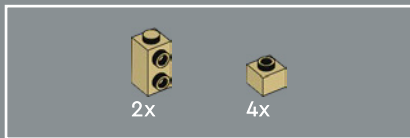

178

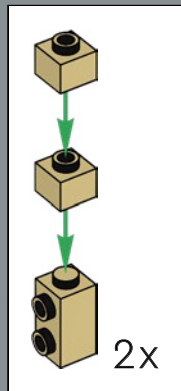

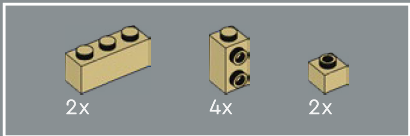

179

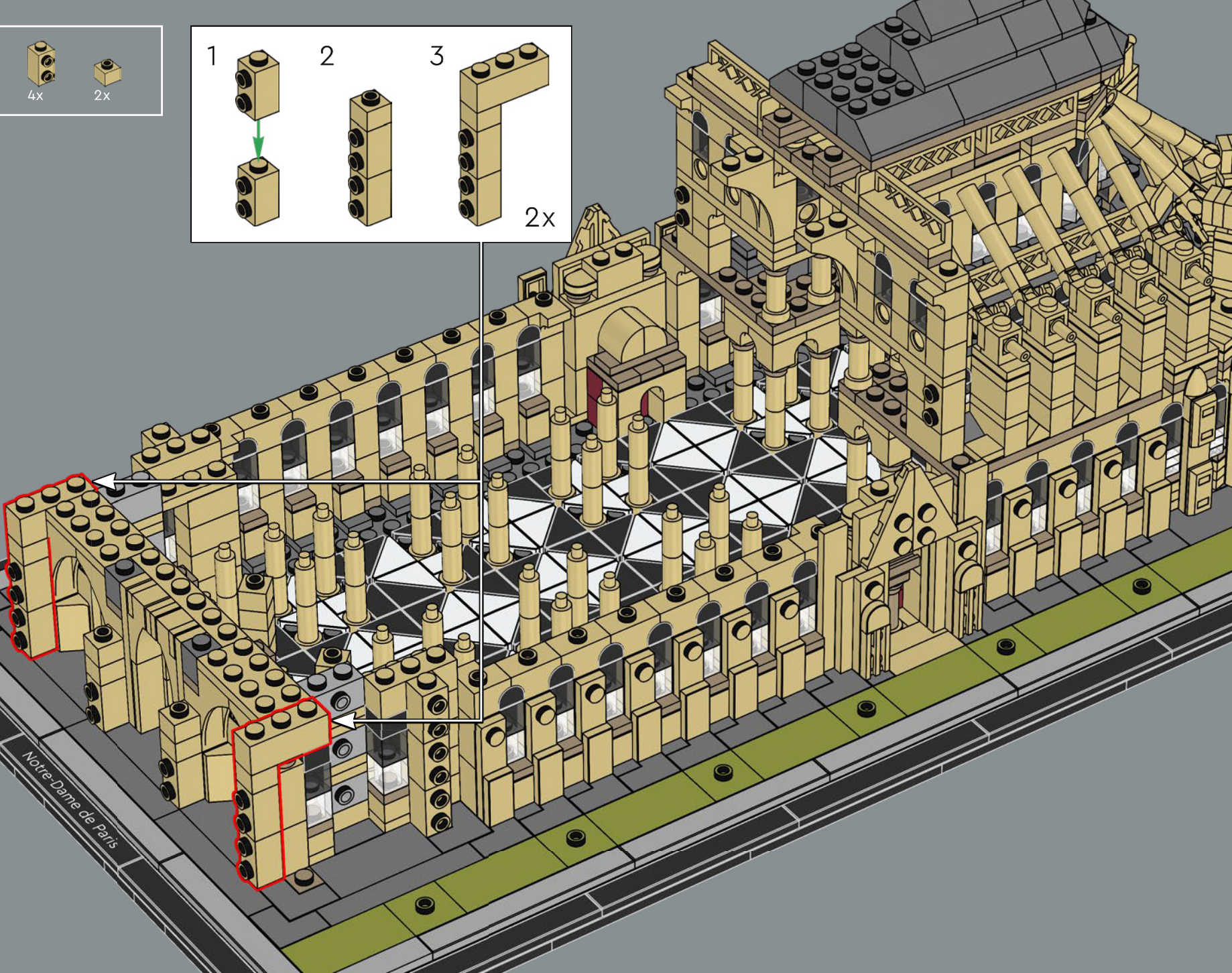
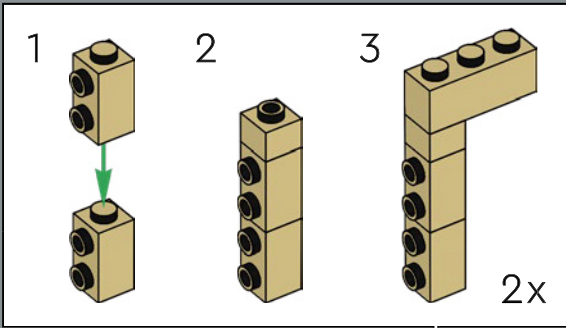

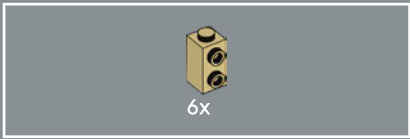

180

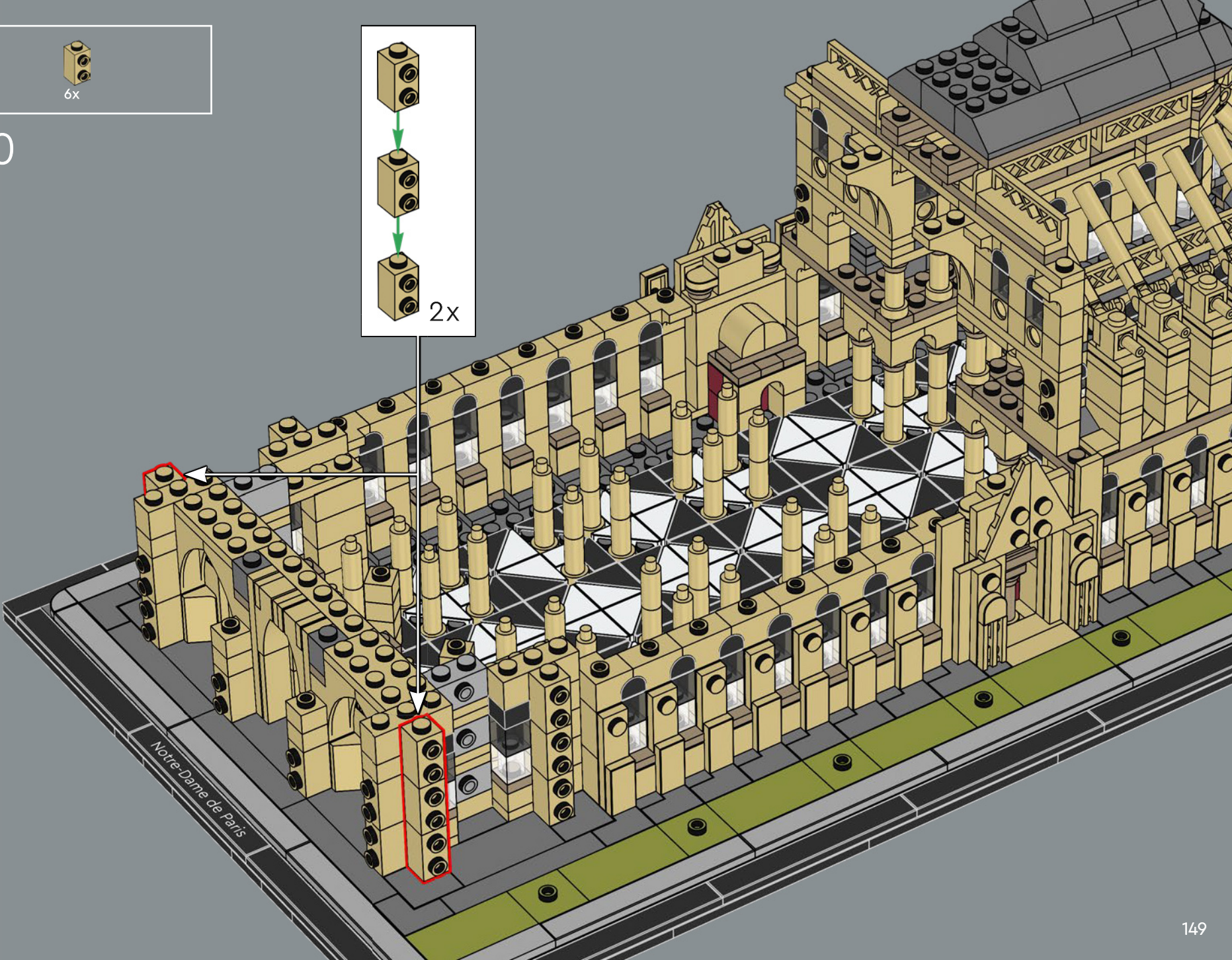
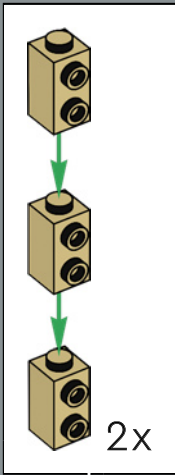

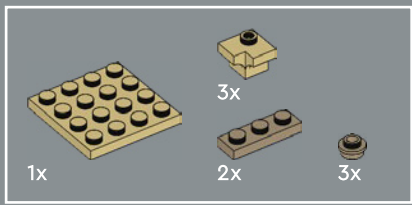

181

1

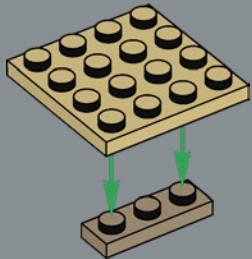

2

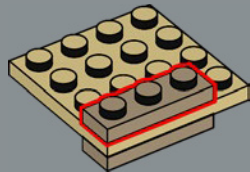

3

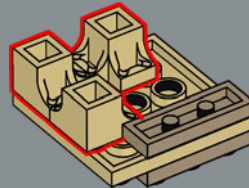

4

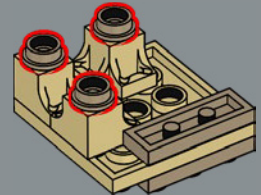



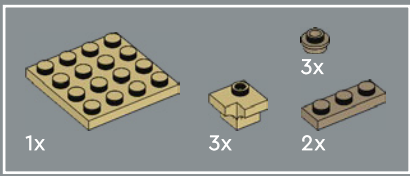

182

1

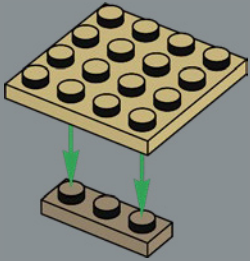

2

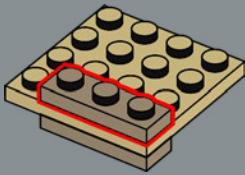

3

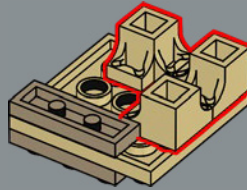

4

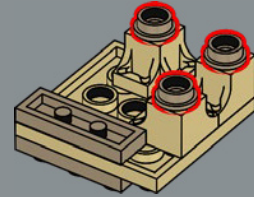



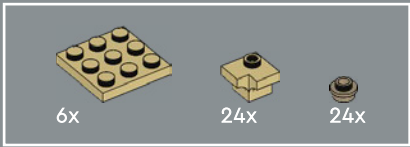

183

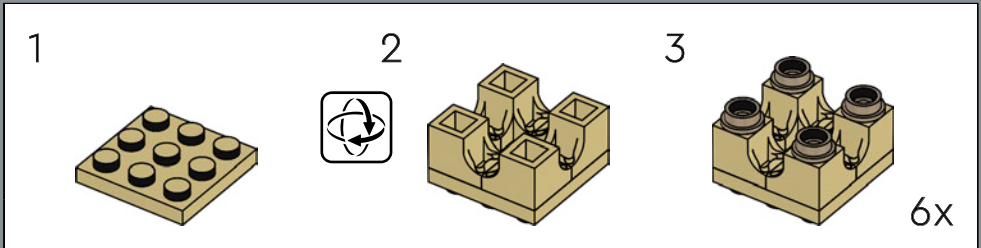

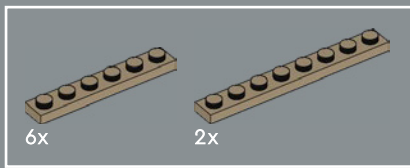



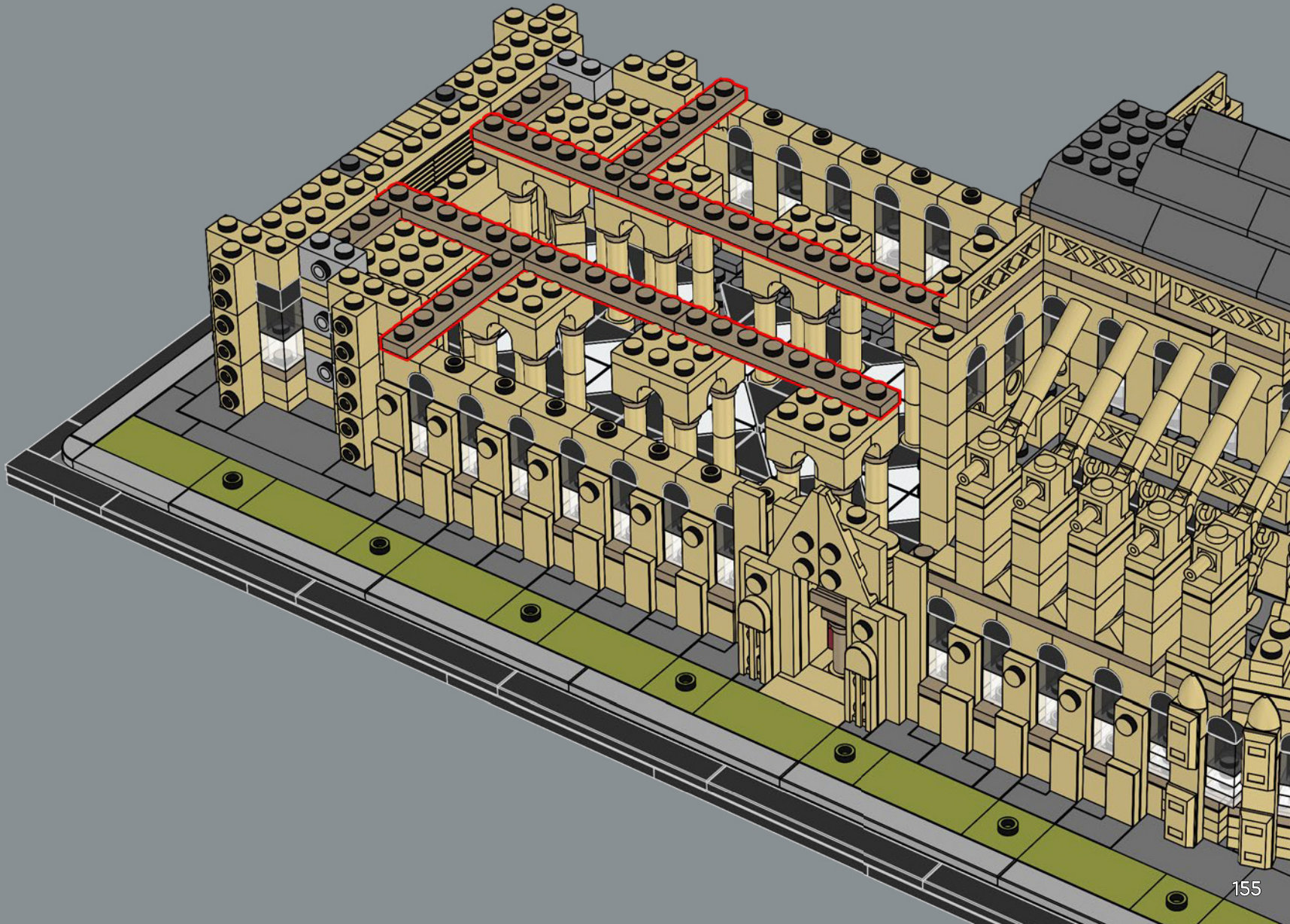

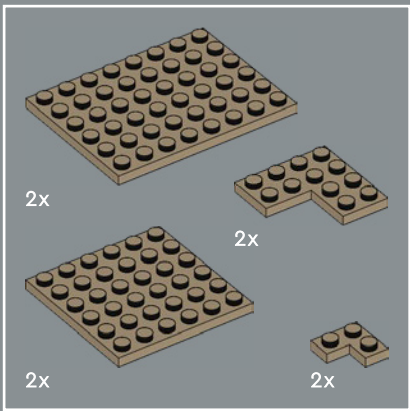
184



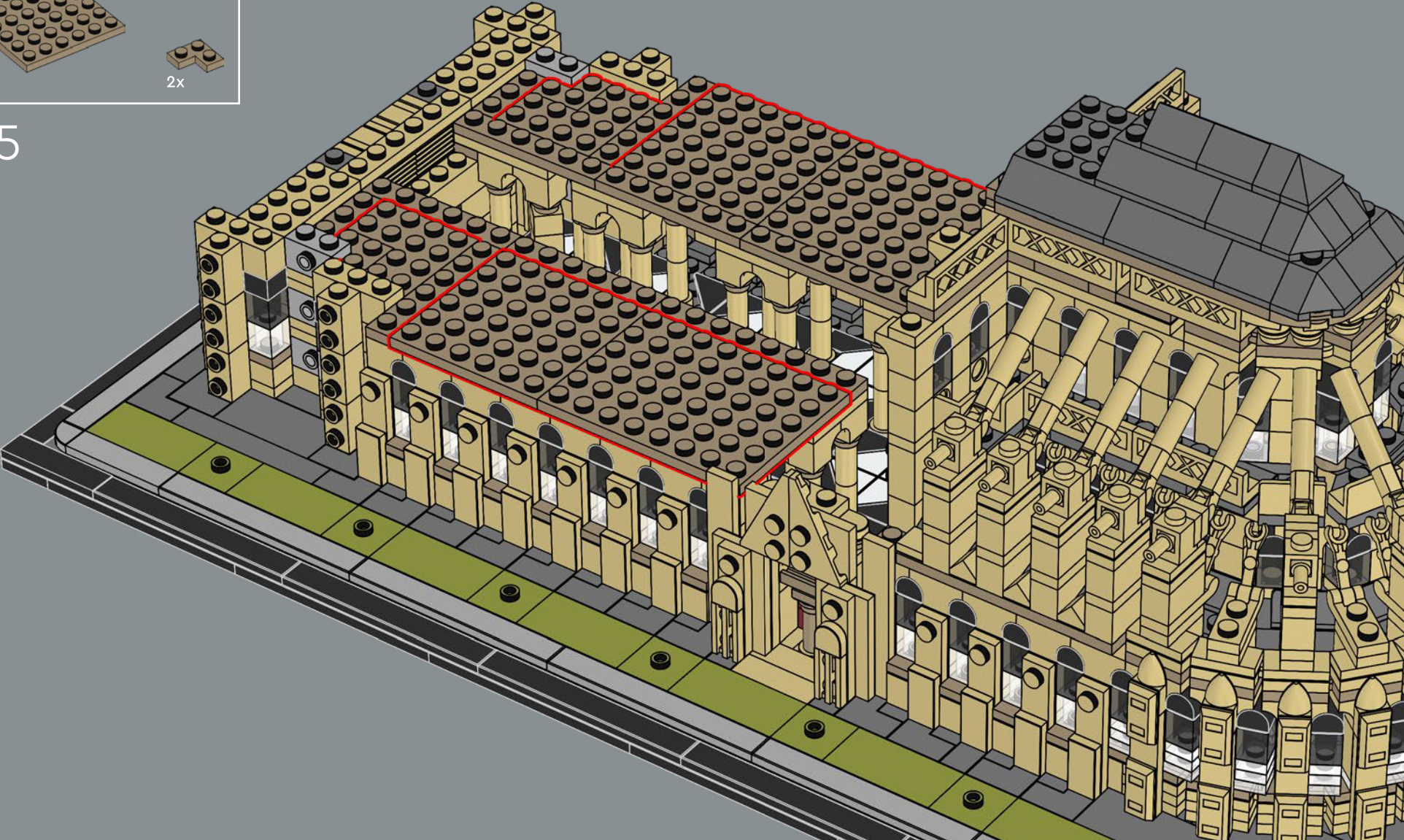

185



| | | |
|--|--|--|
|  |  |  |
| 2x | 2x | 12x |

186



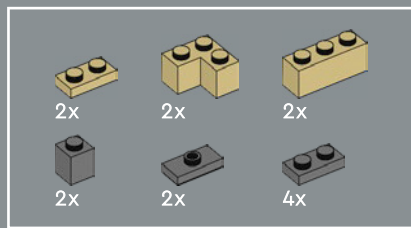

187

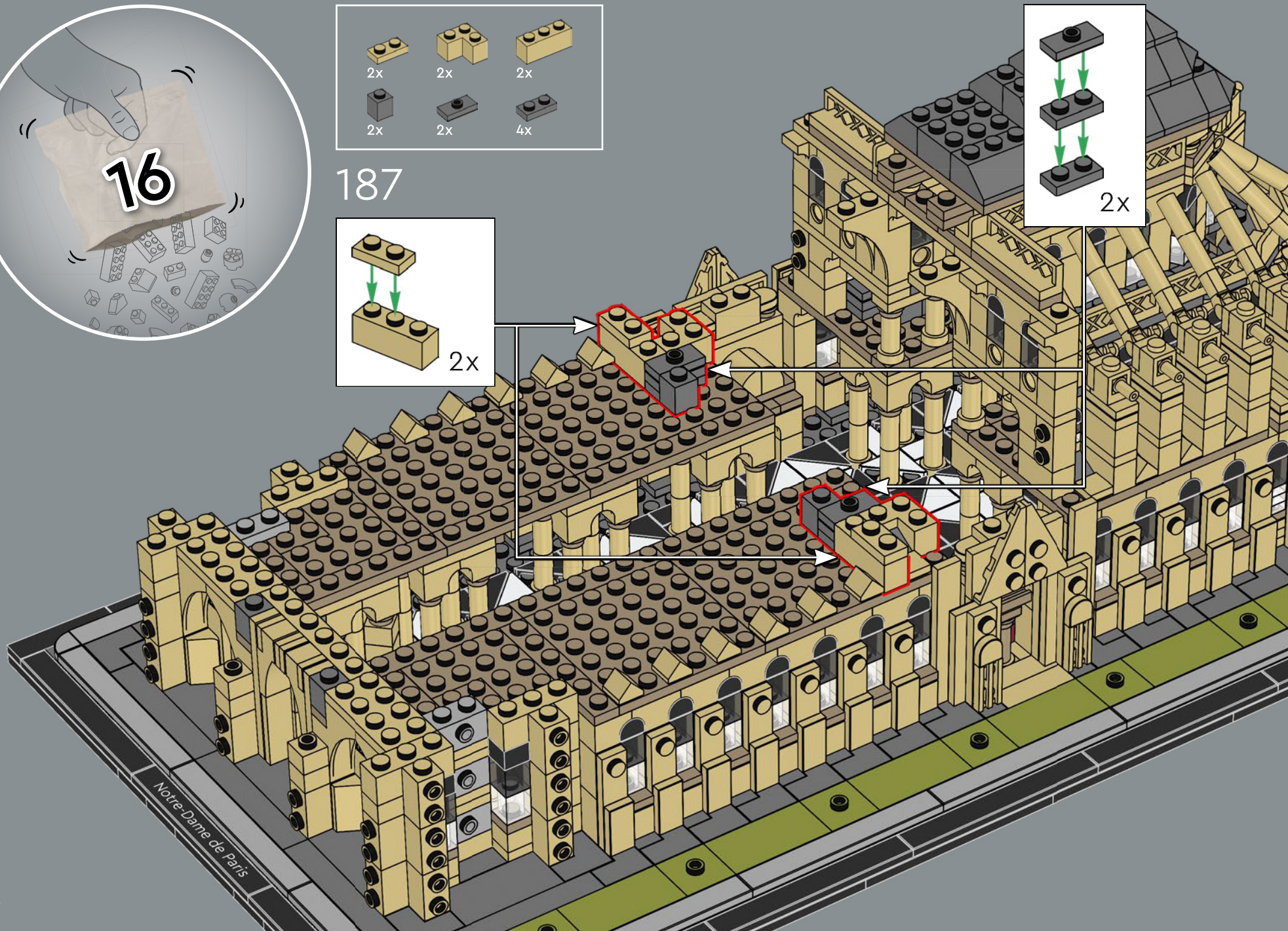
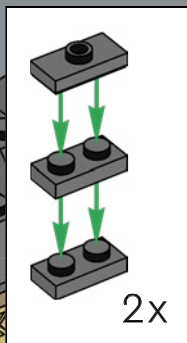
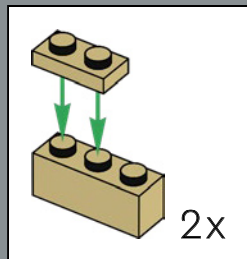

Notre-Dame de Paris

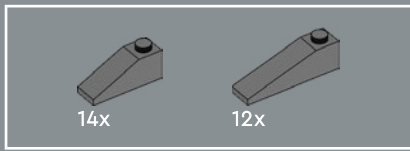

188

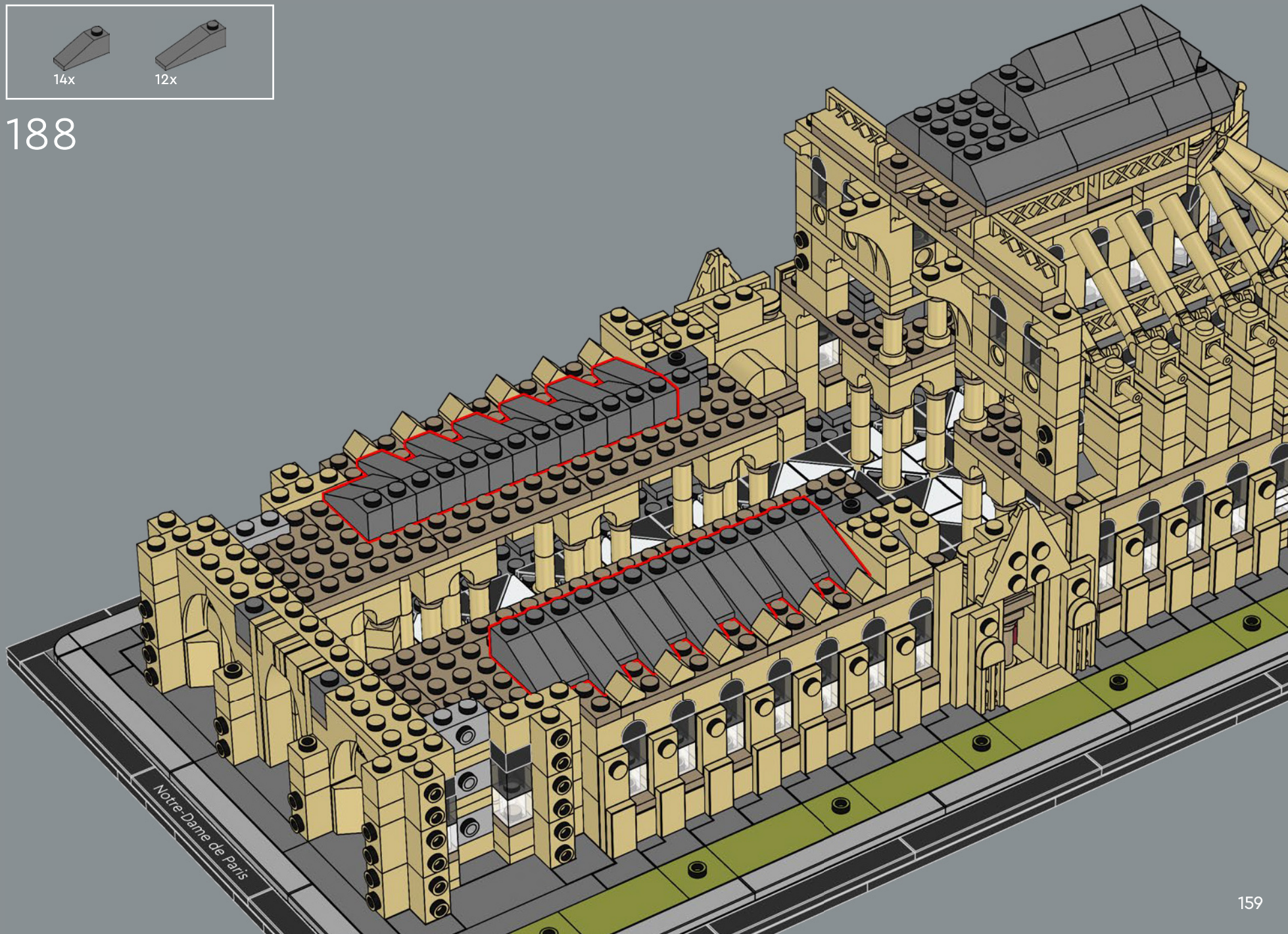

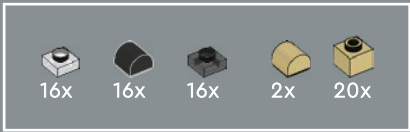

189

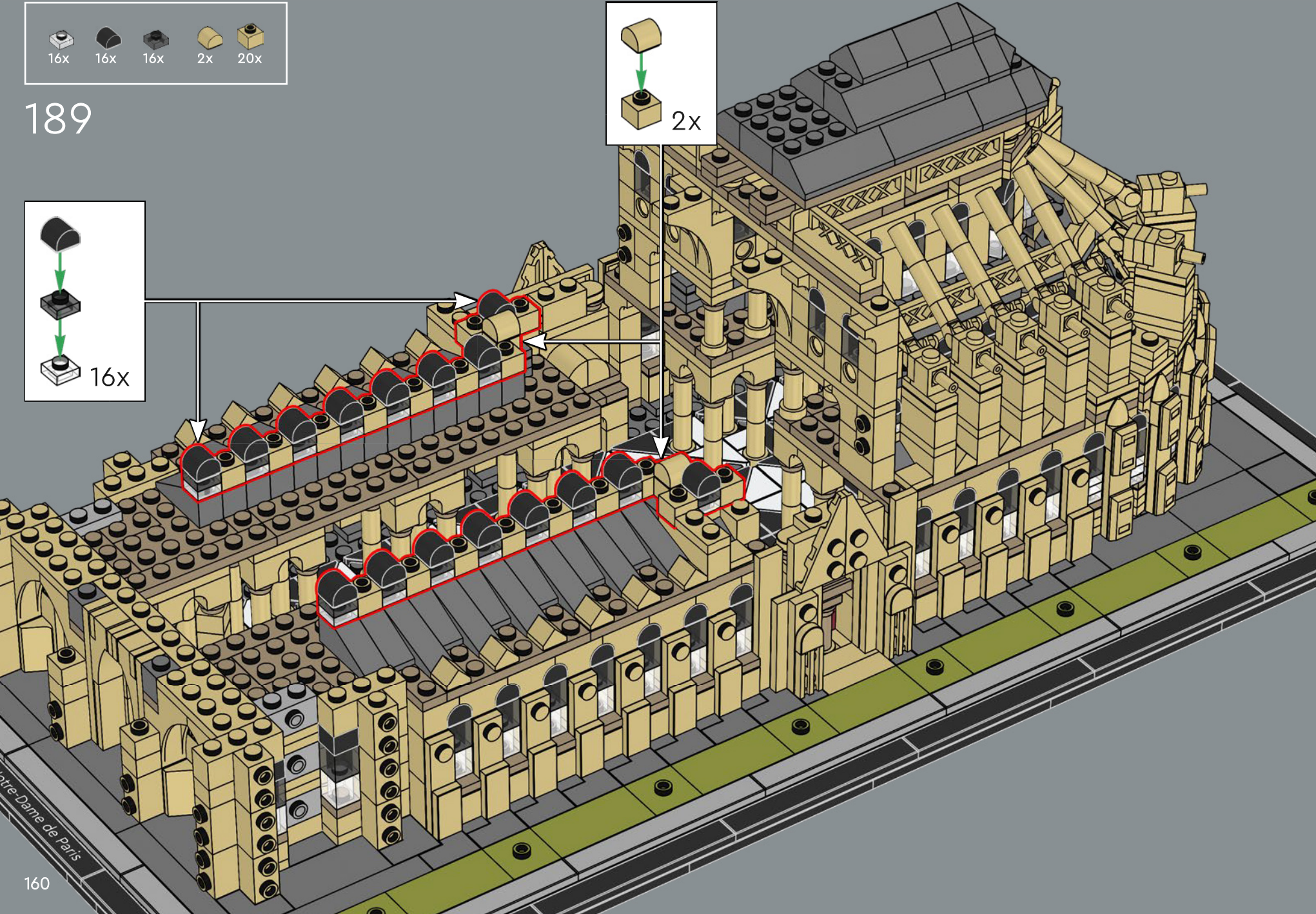
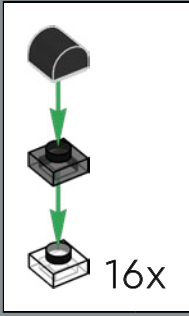
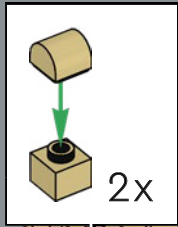

Notre-Dame de Paris

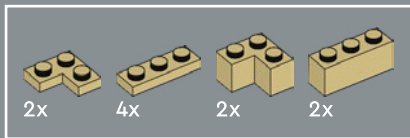

190

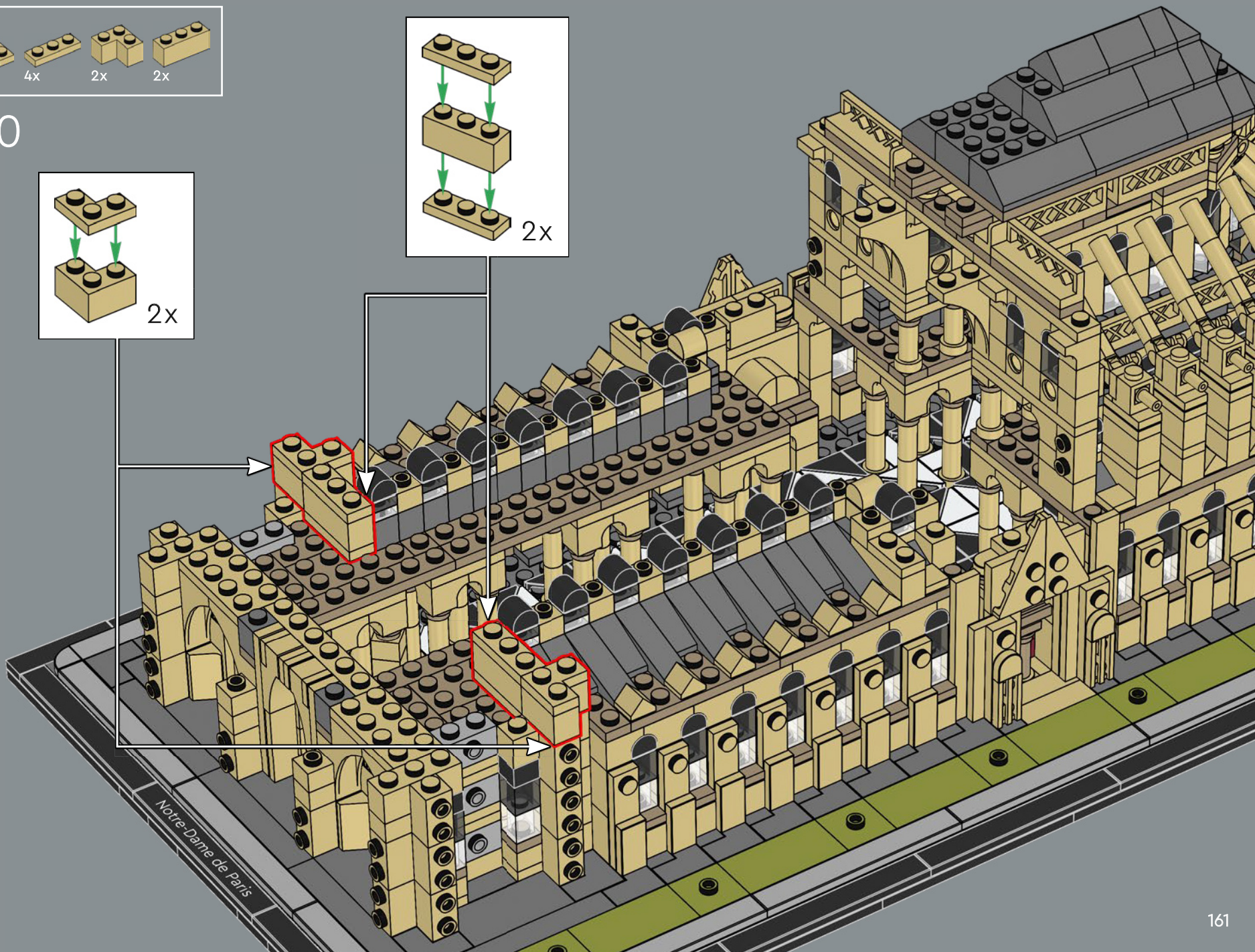
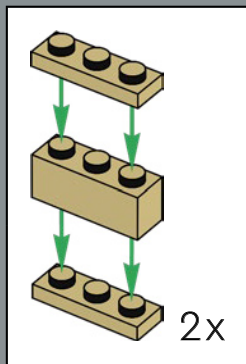
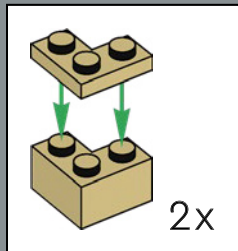



6x

191

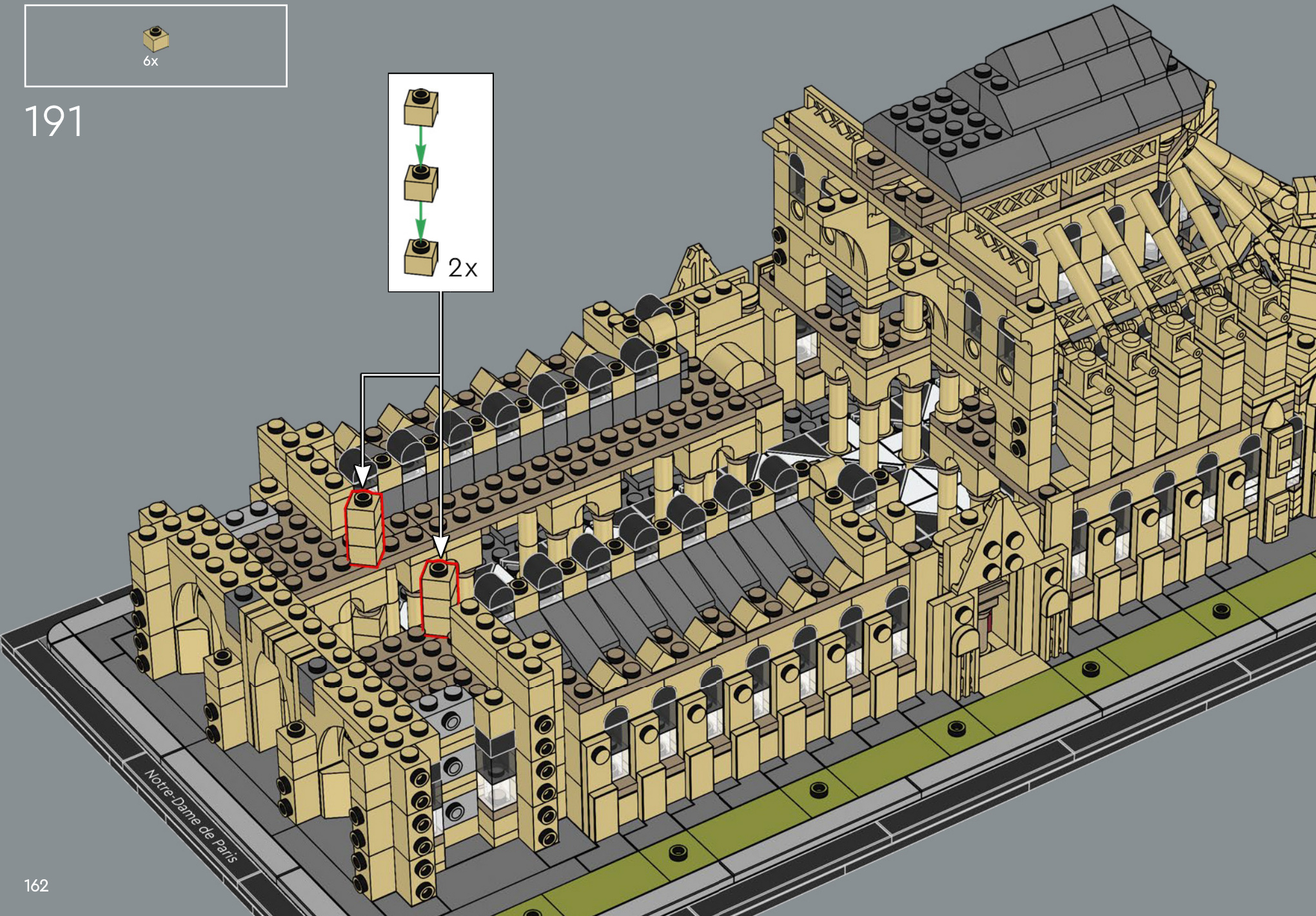
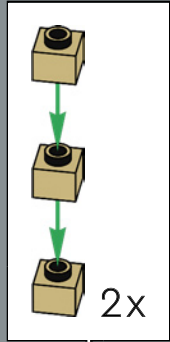

Notre-Dame de Paris

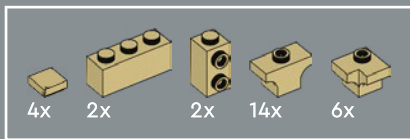

192

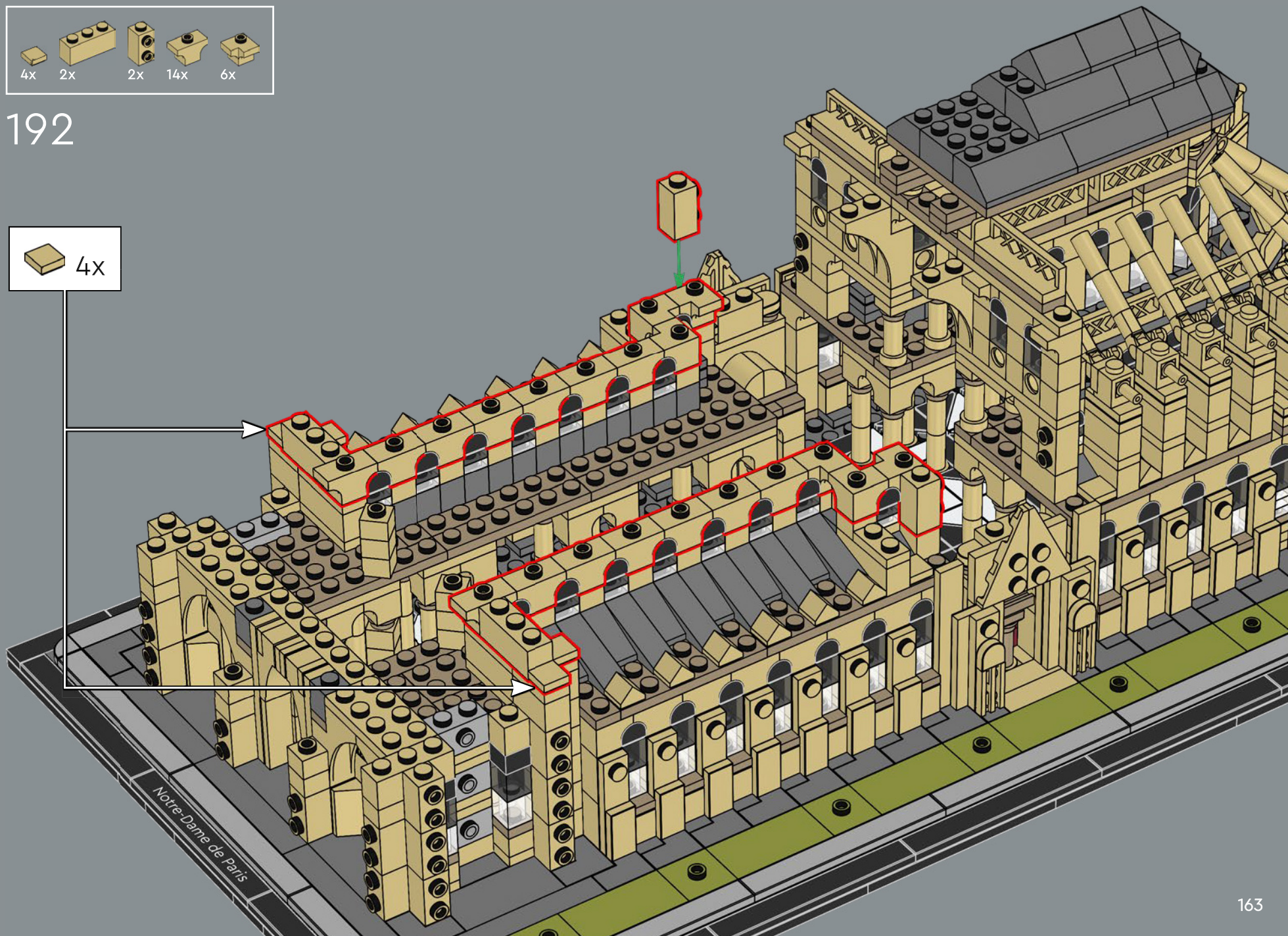

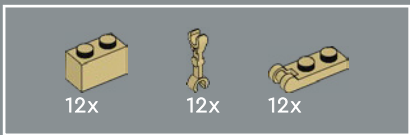

193

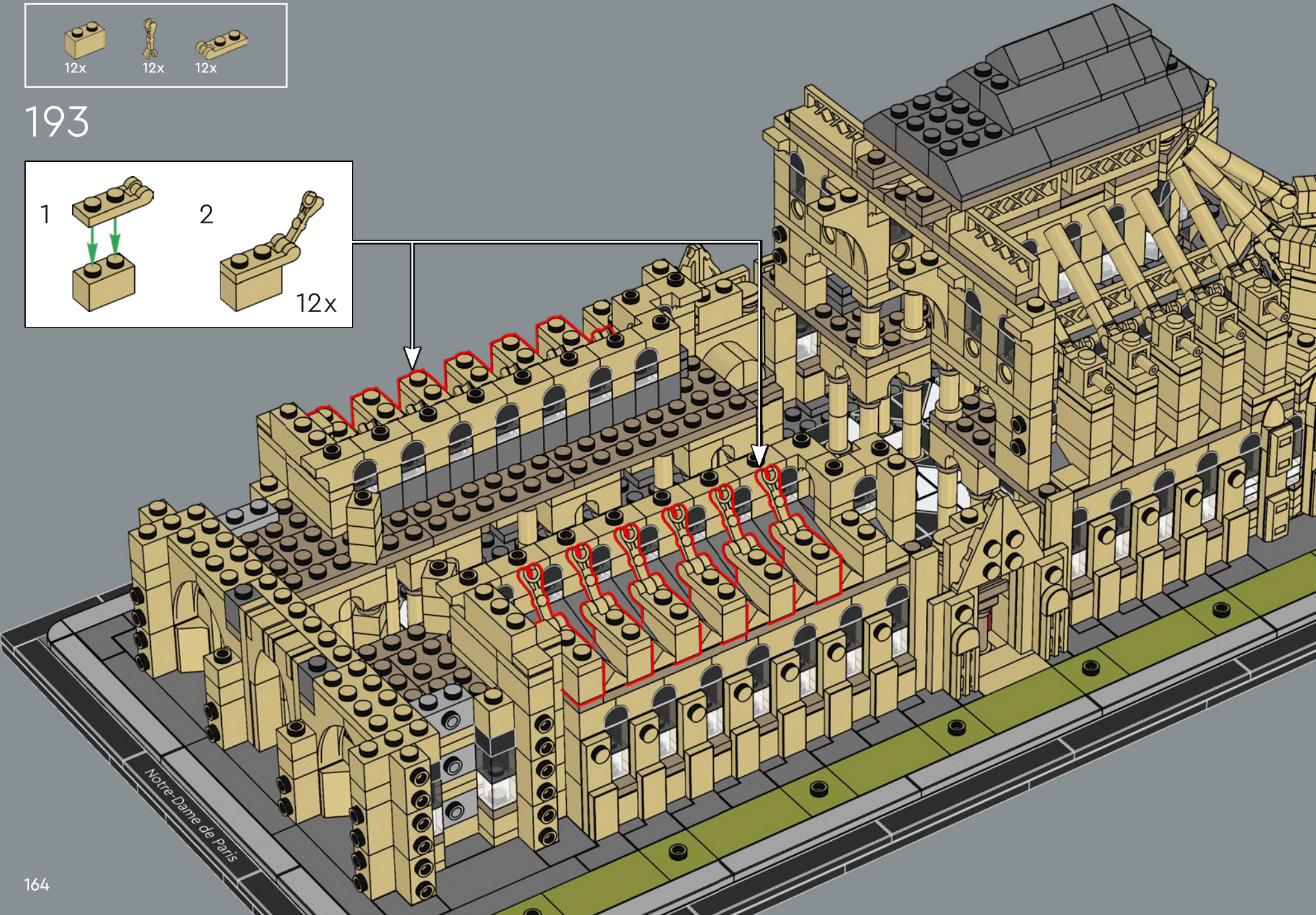
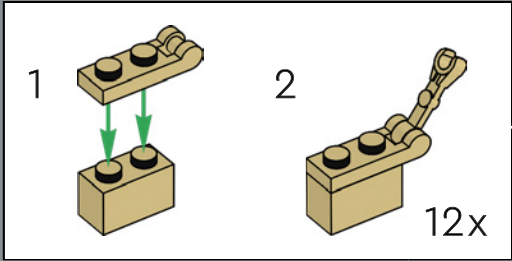



194

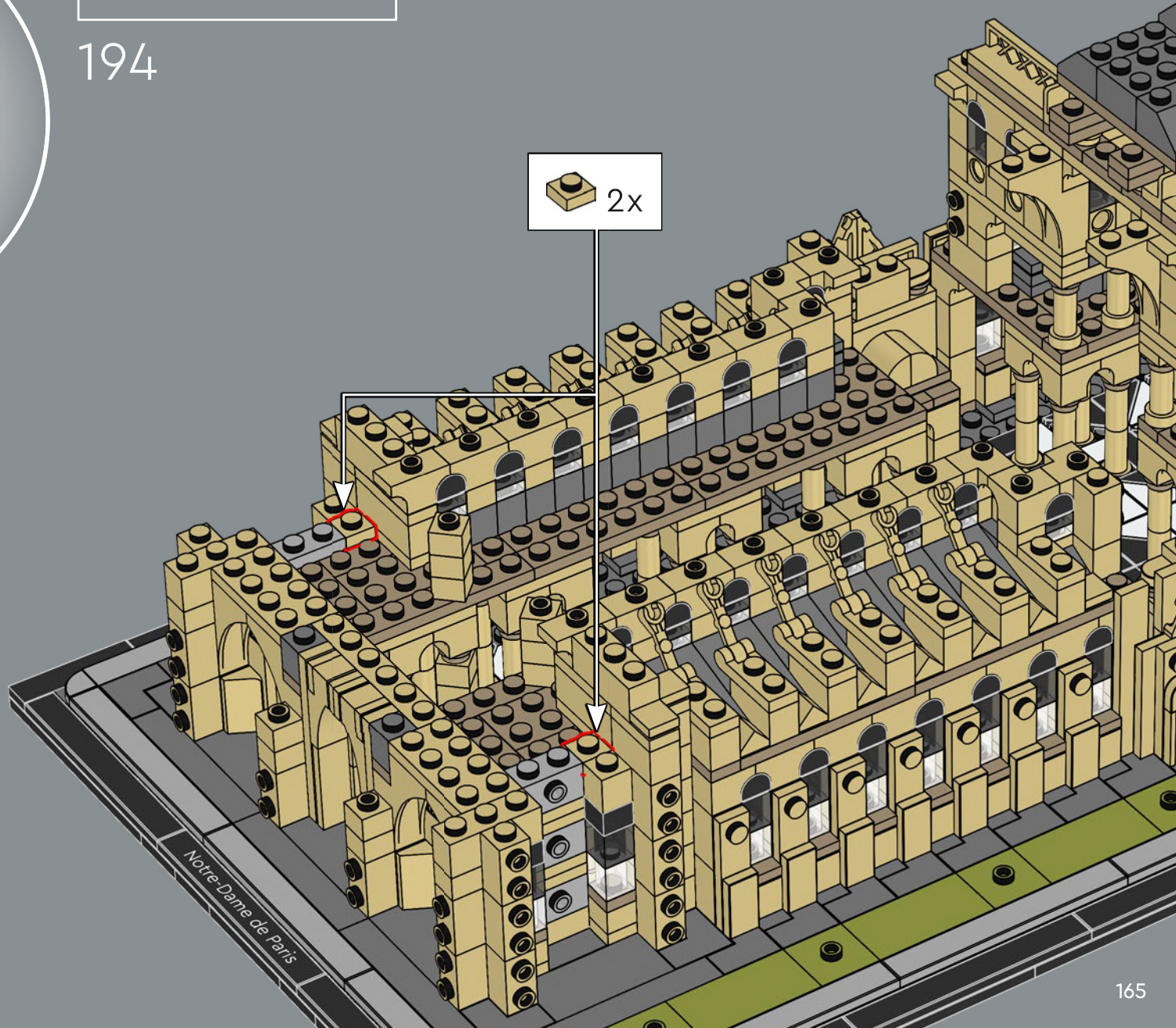

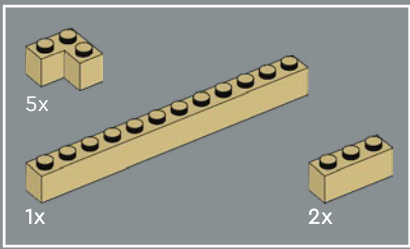

195

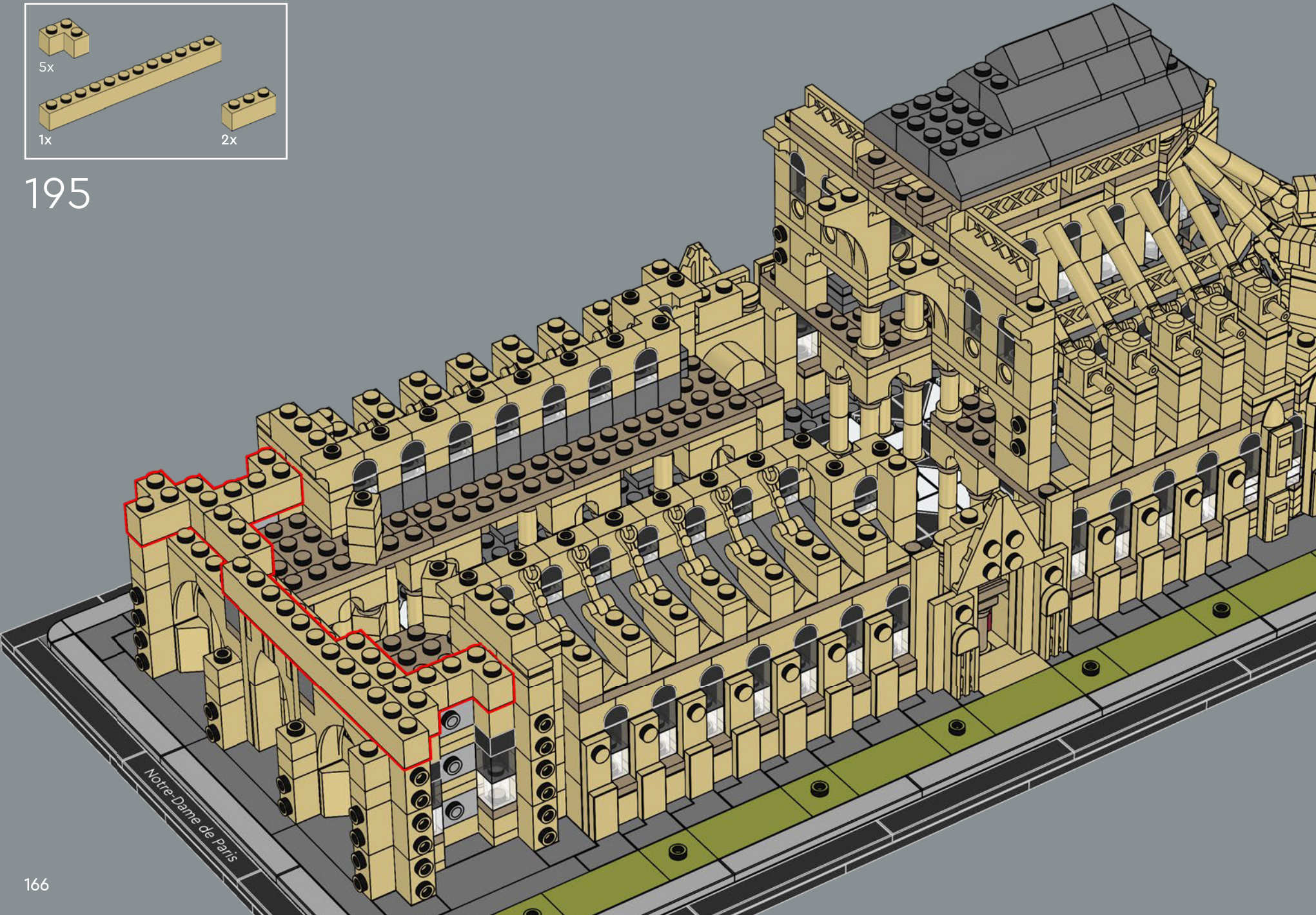

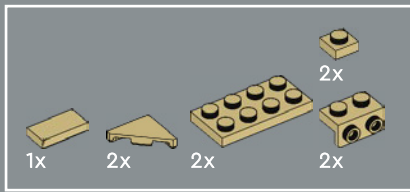

196

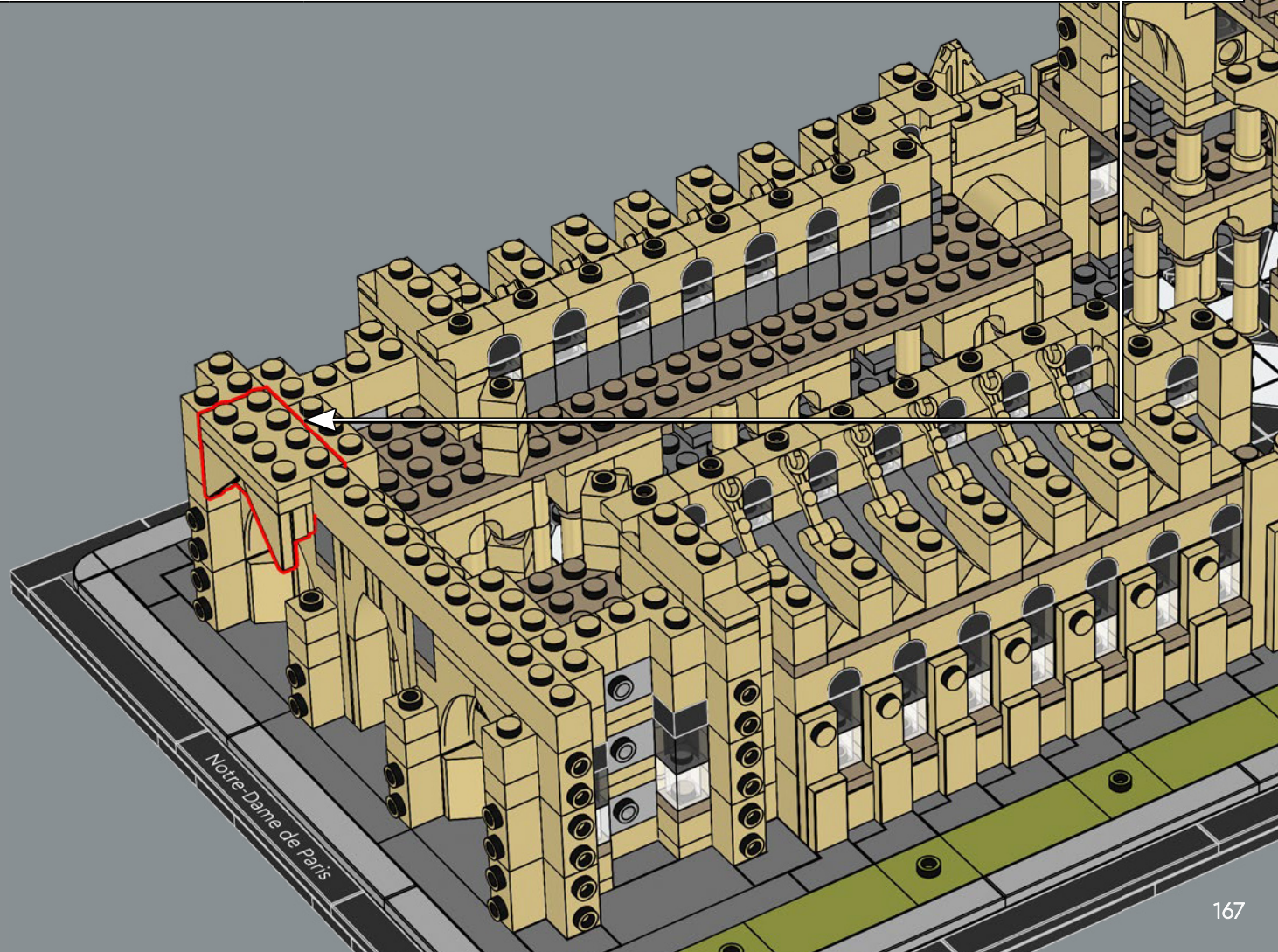
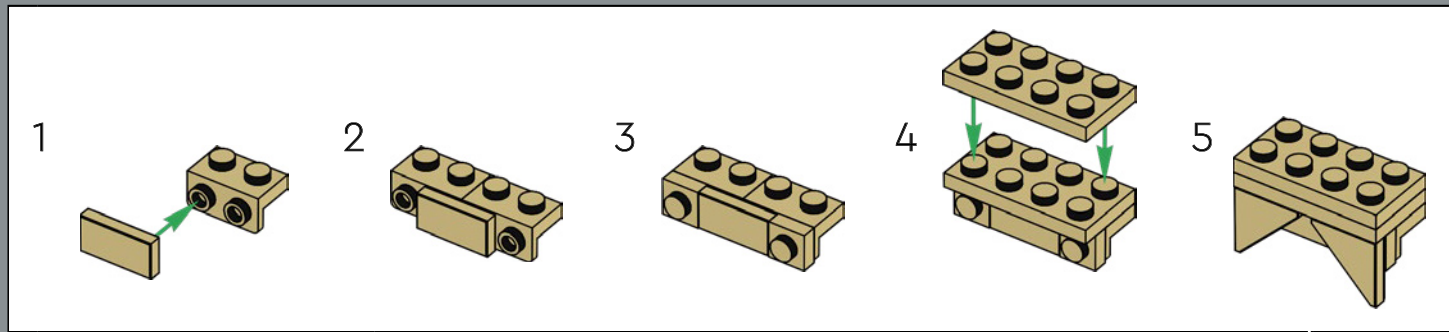

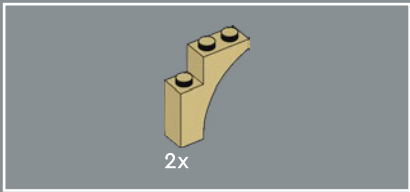

197

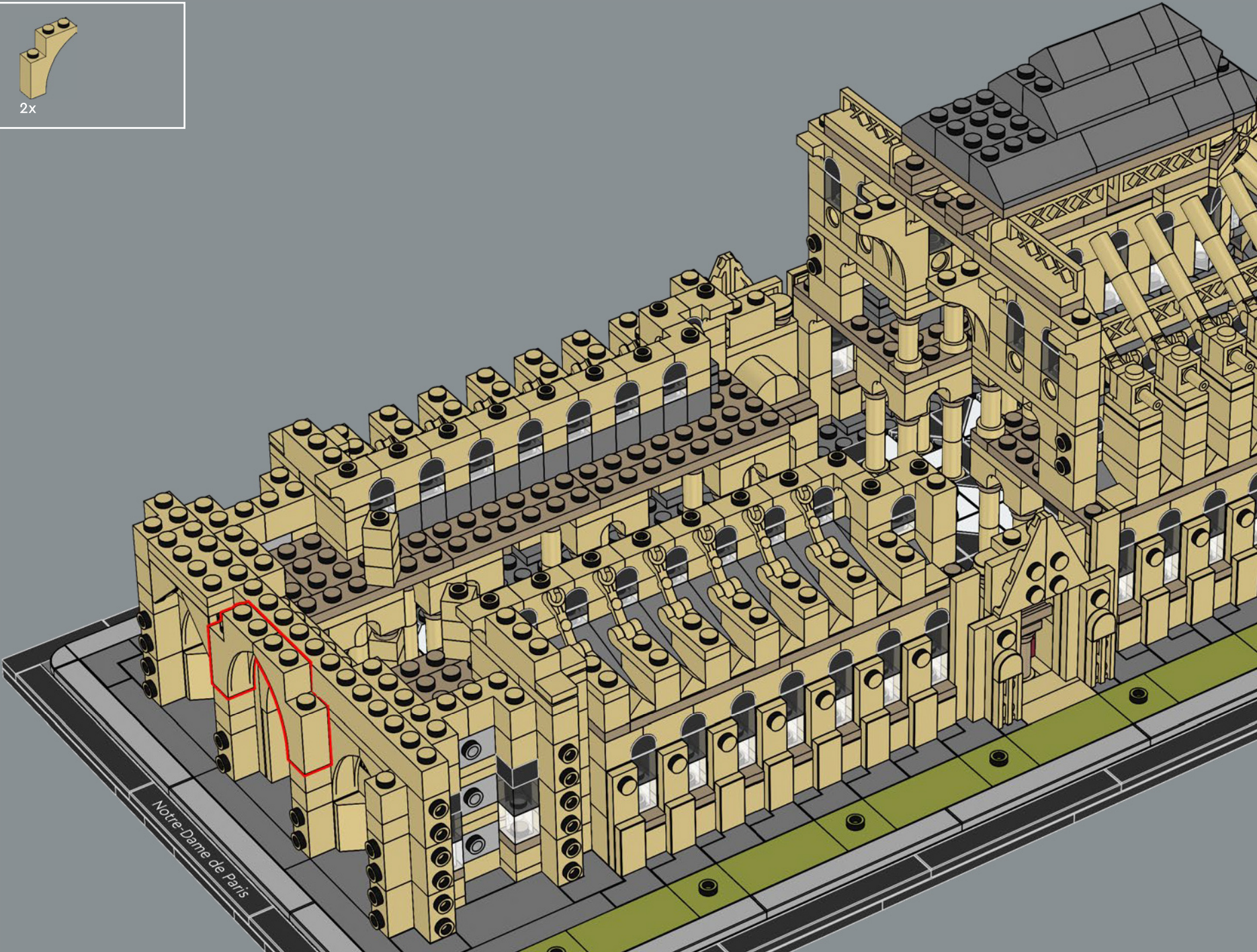

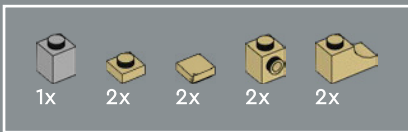

198

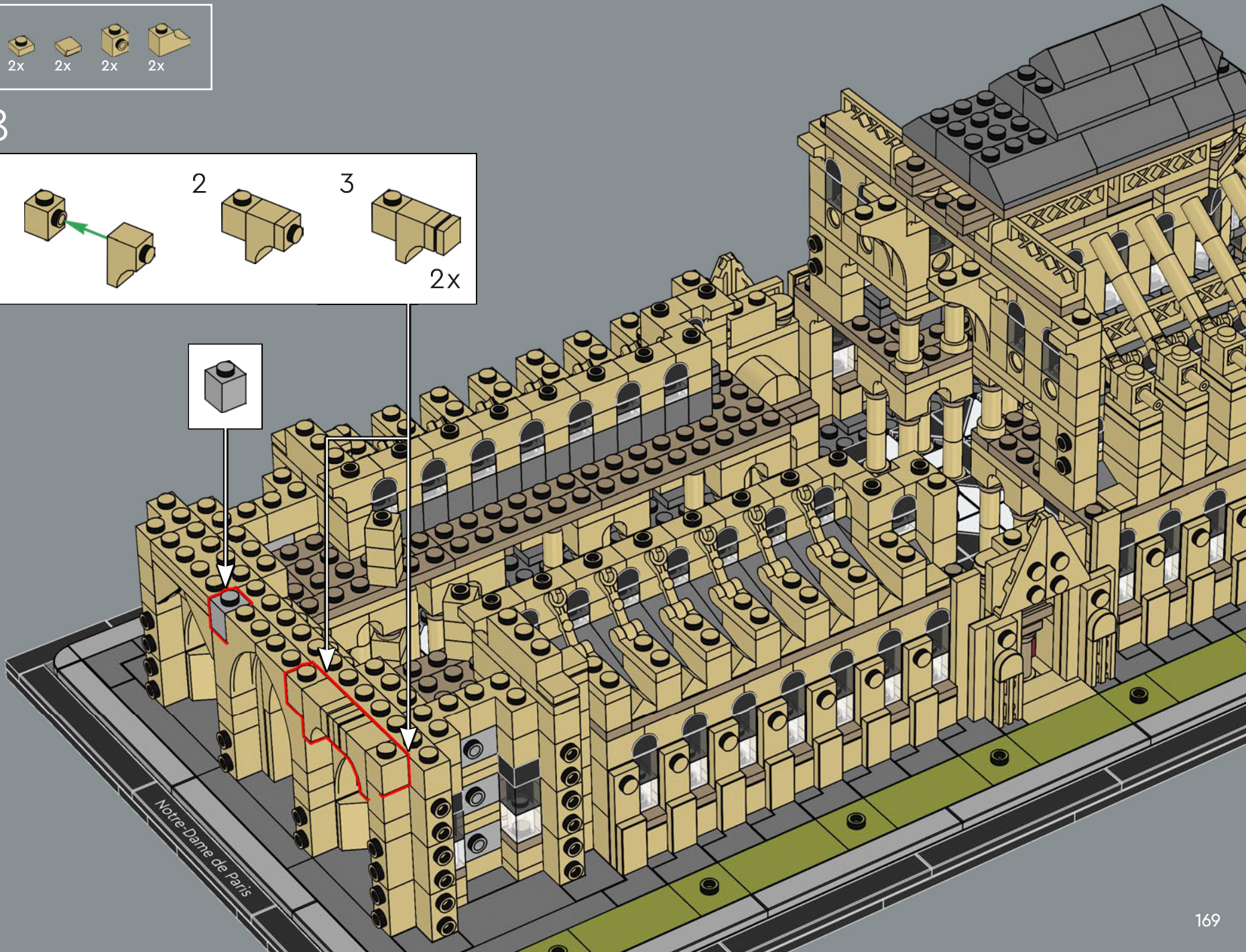
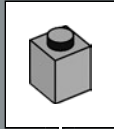
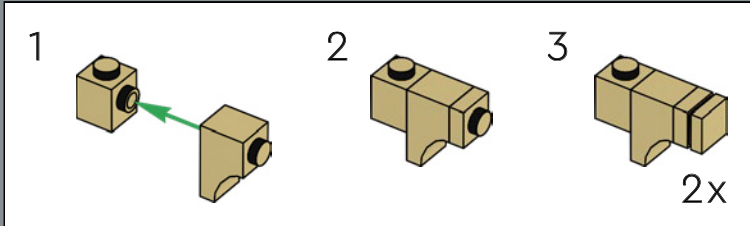

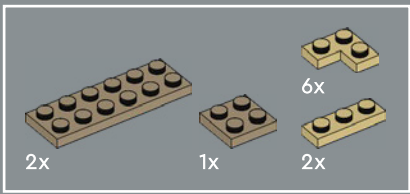

199



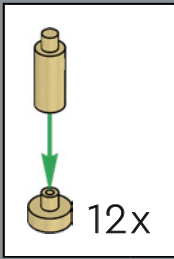

200

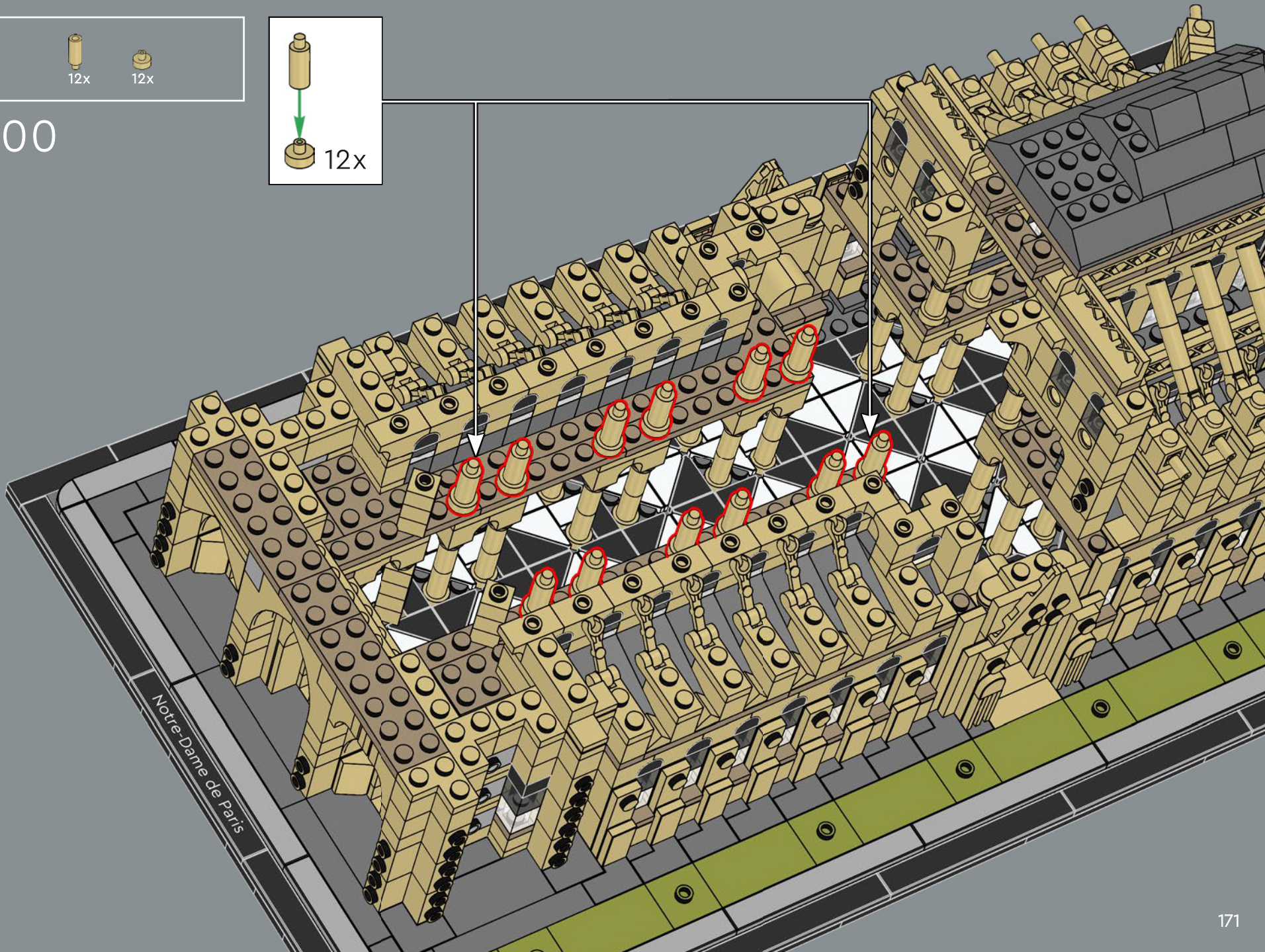

Notre-Dame de Paris

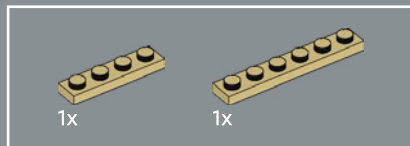
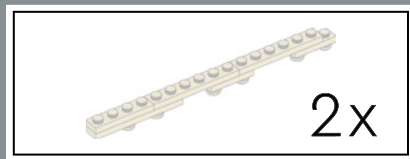

201

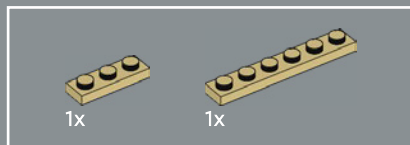
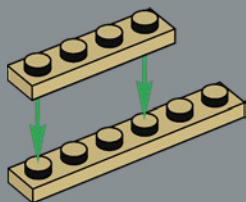

202

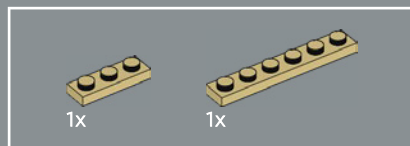
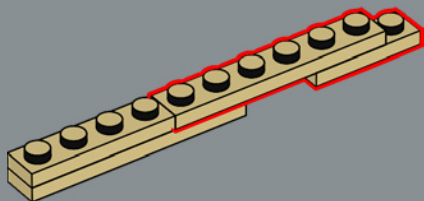

203

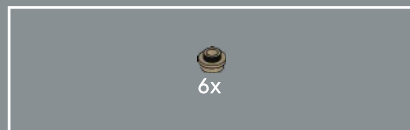
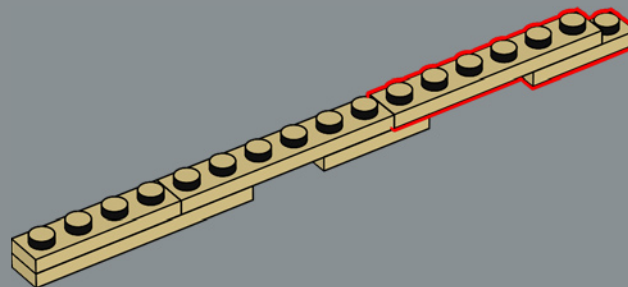

204

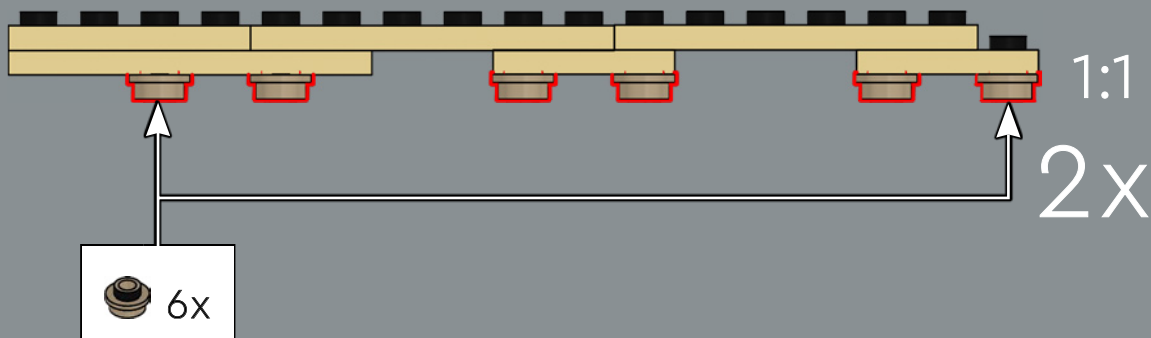

205

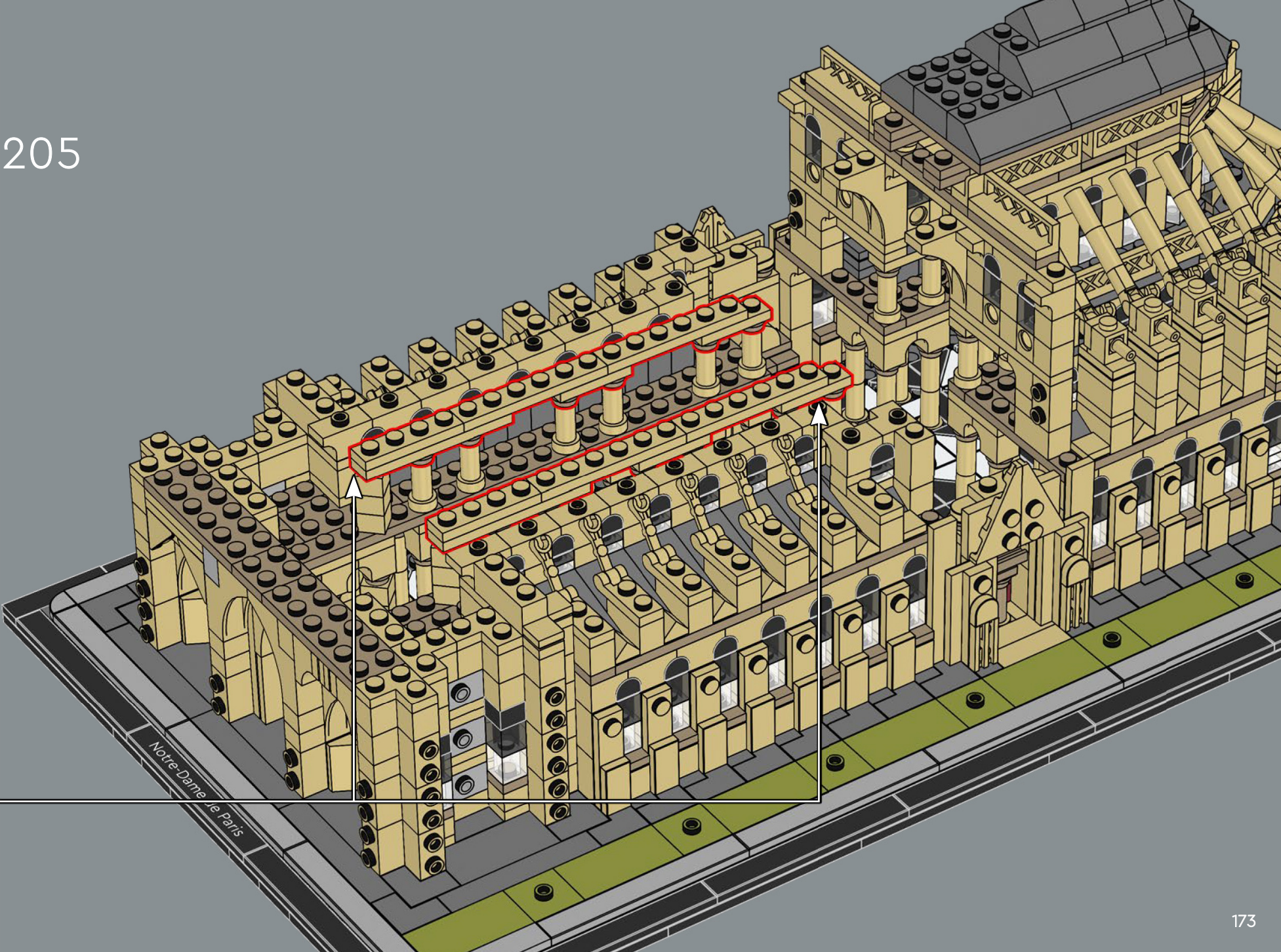

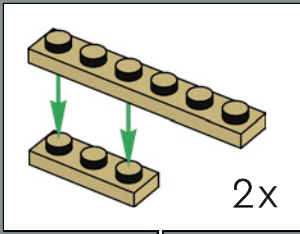
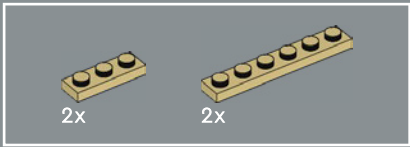

206

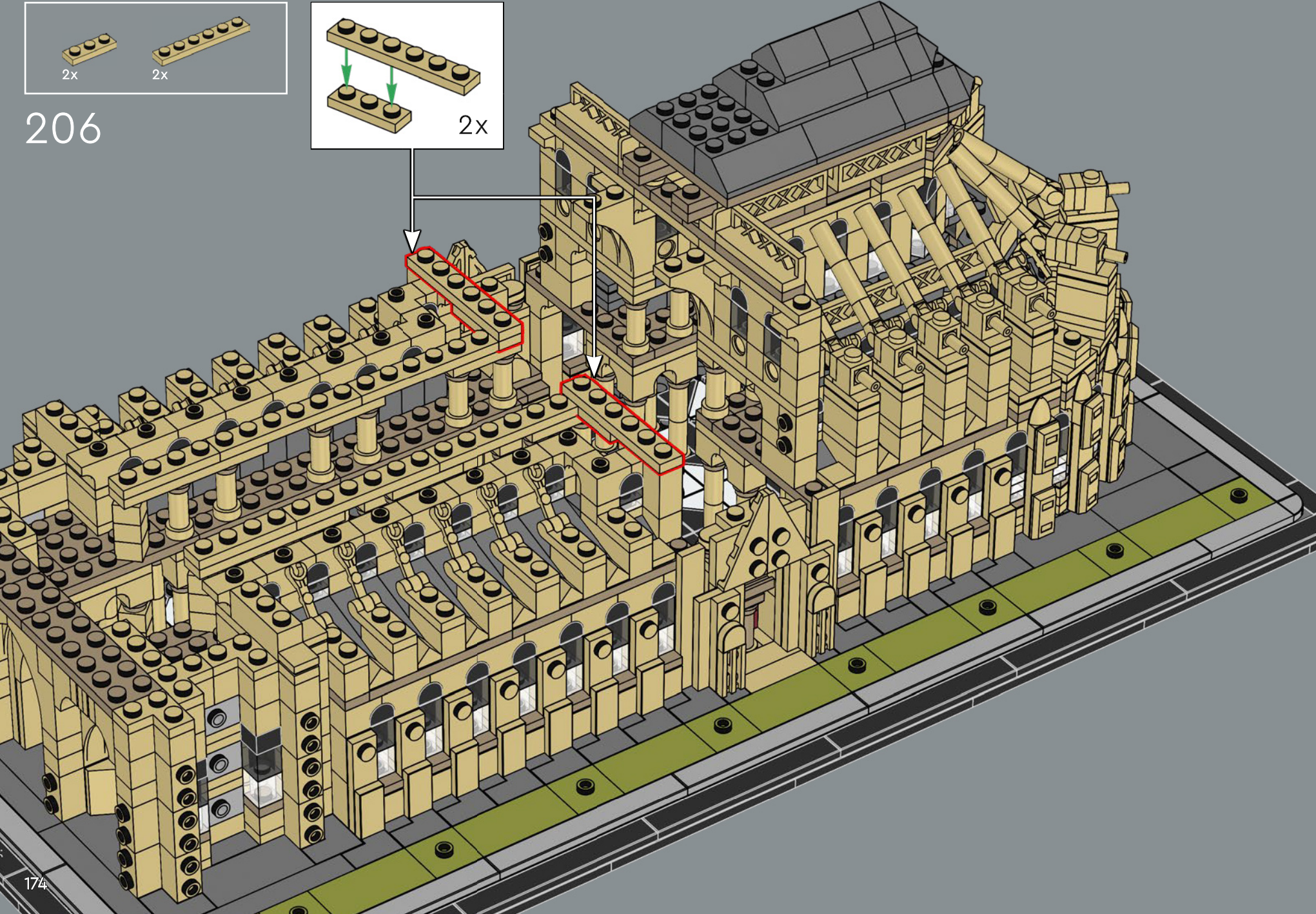

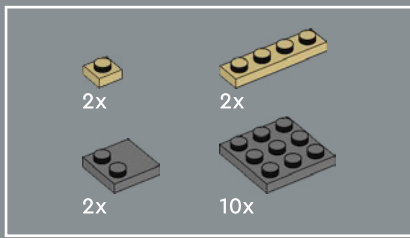

207





208

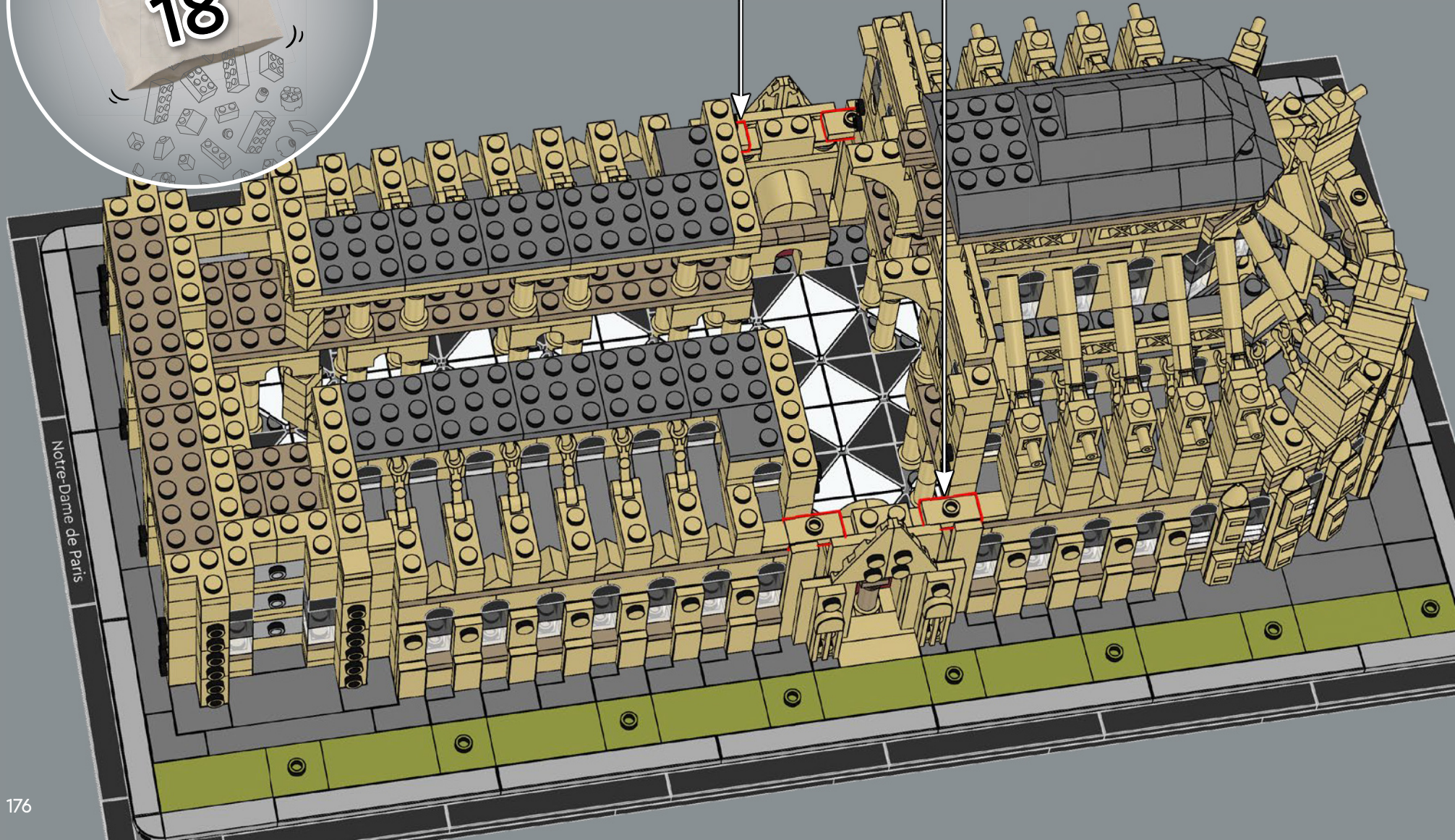
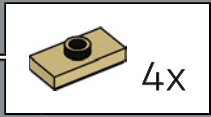

Notre-Dame de Paris

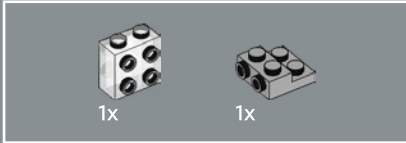
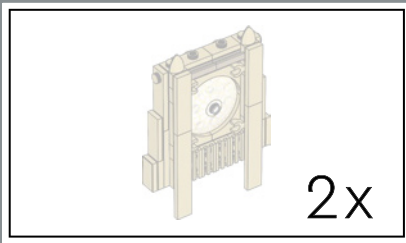

209

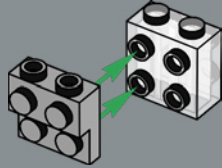

210

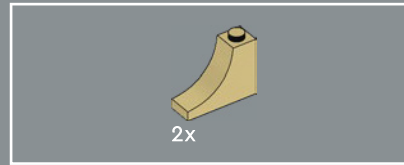
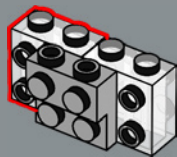

211

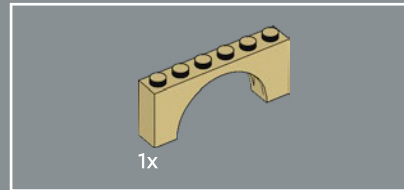
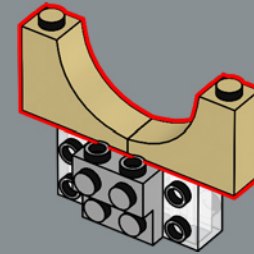

212

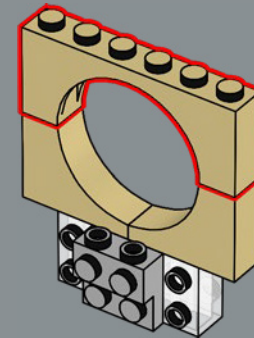

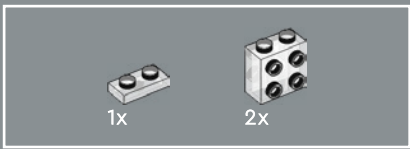

213

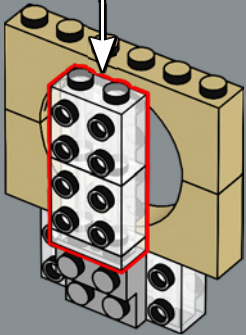
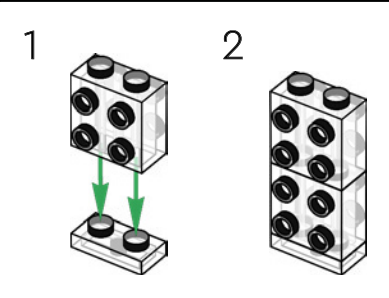

214

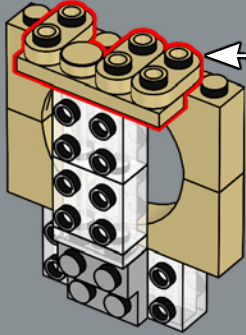
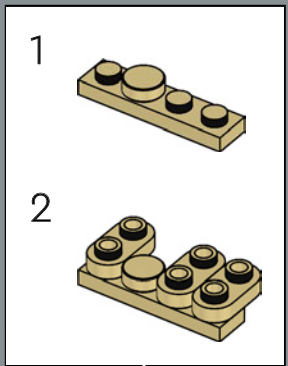

215

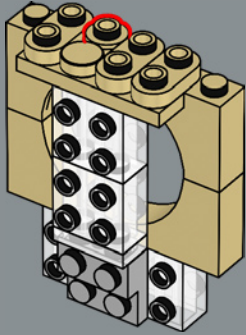

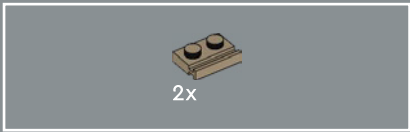

216

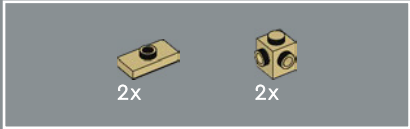
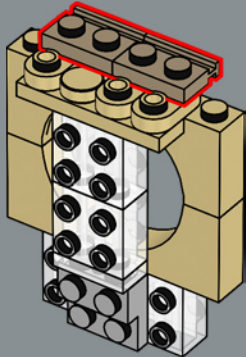

217

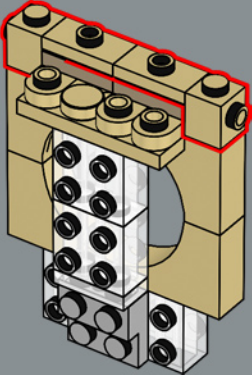

218

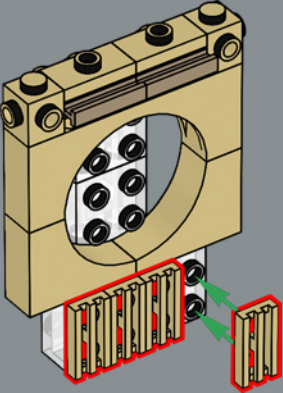

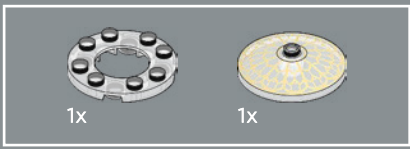

219

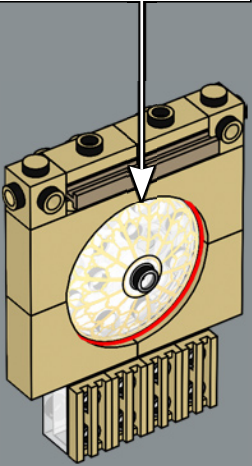
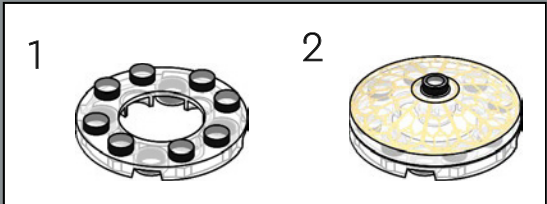

220

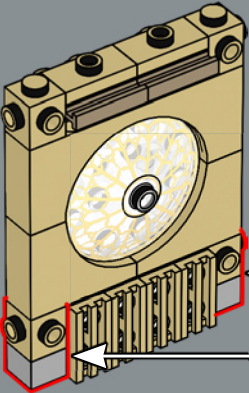
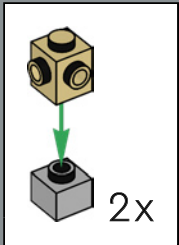

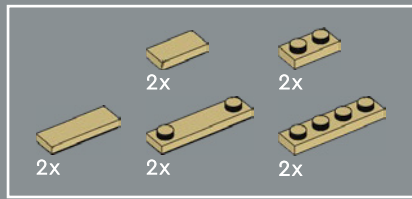

221

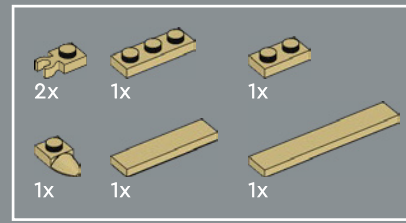
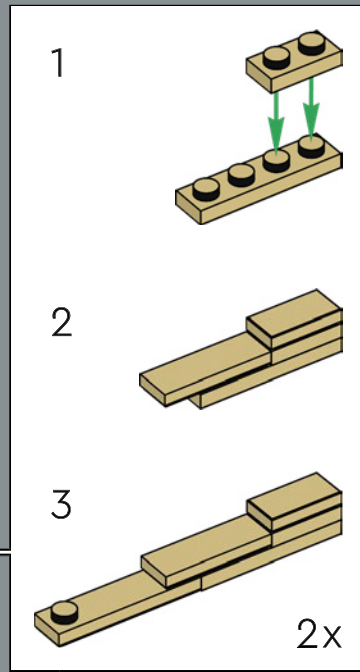
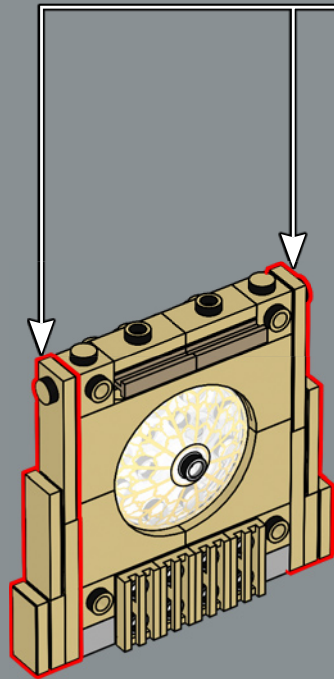

222

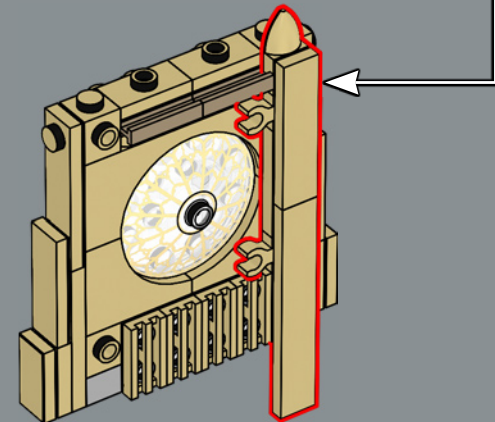
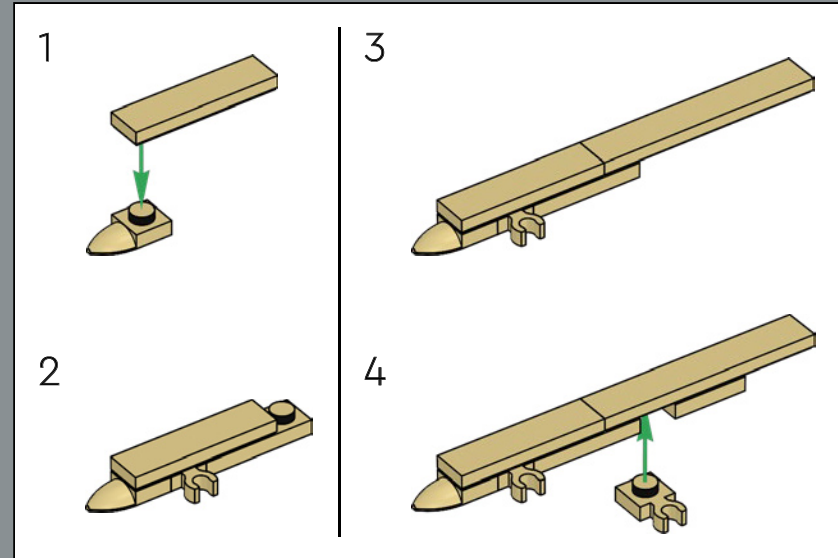

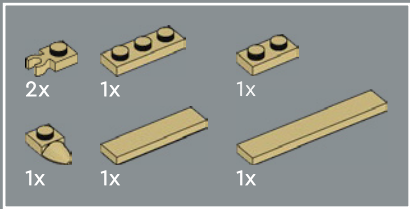

223

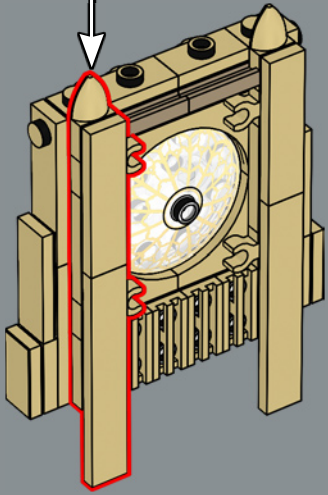
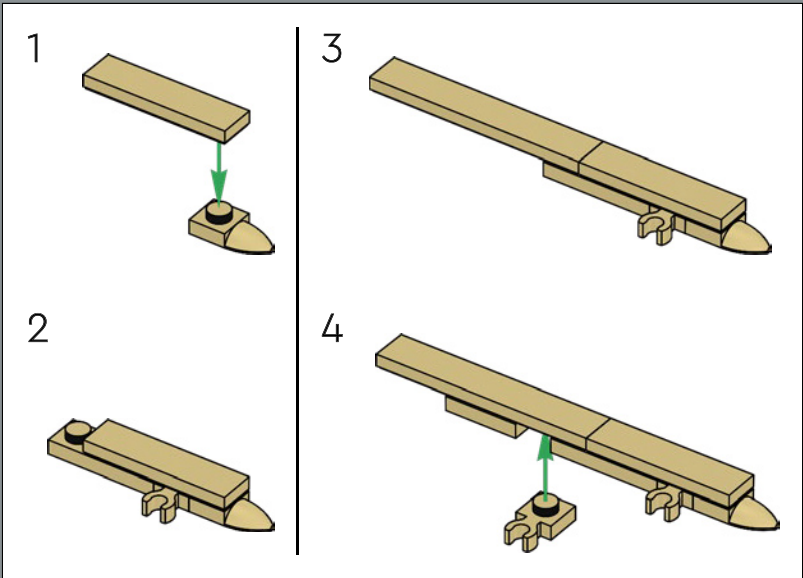

224

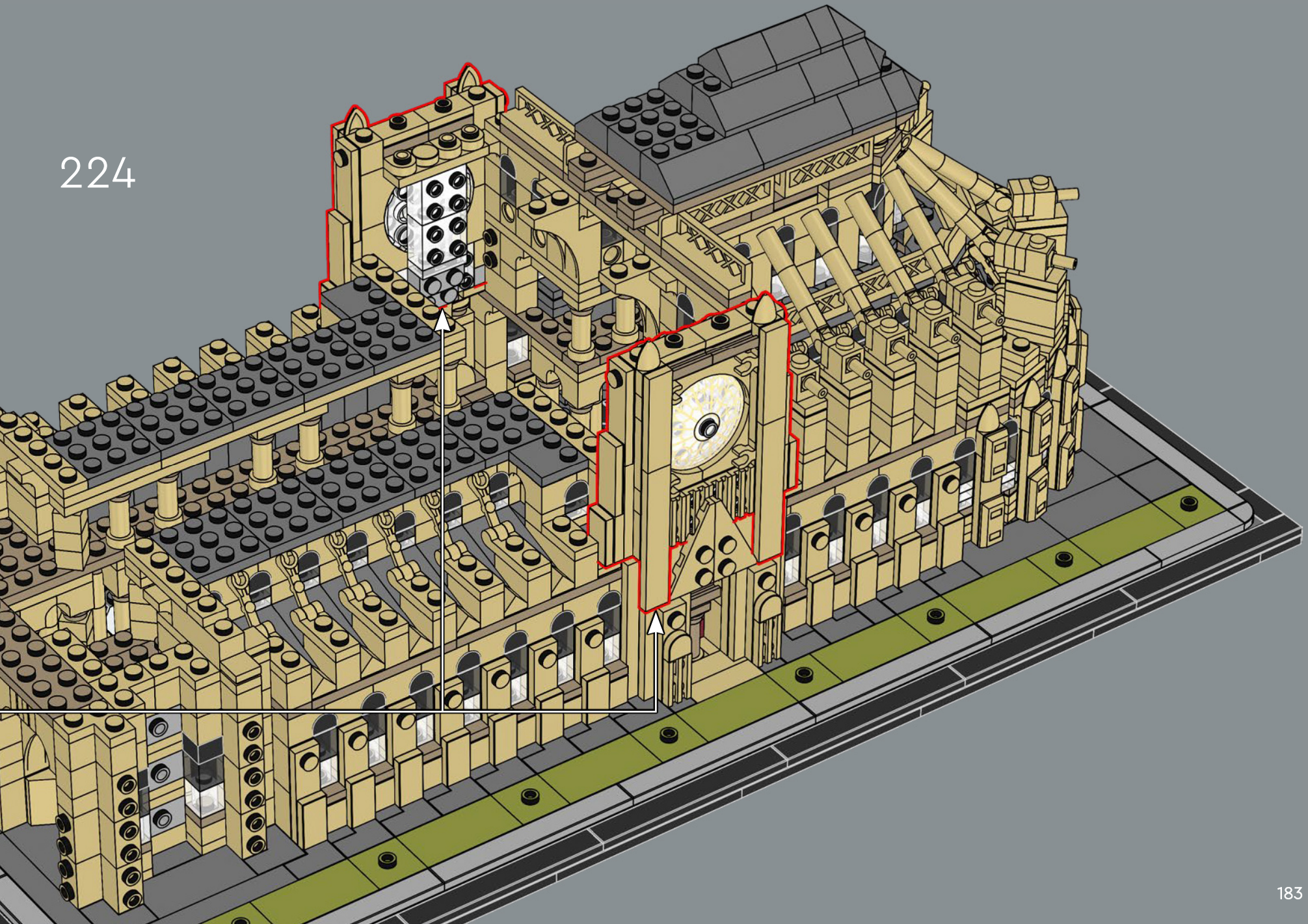

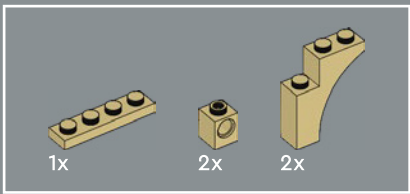

225

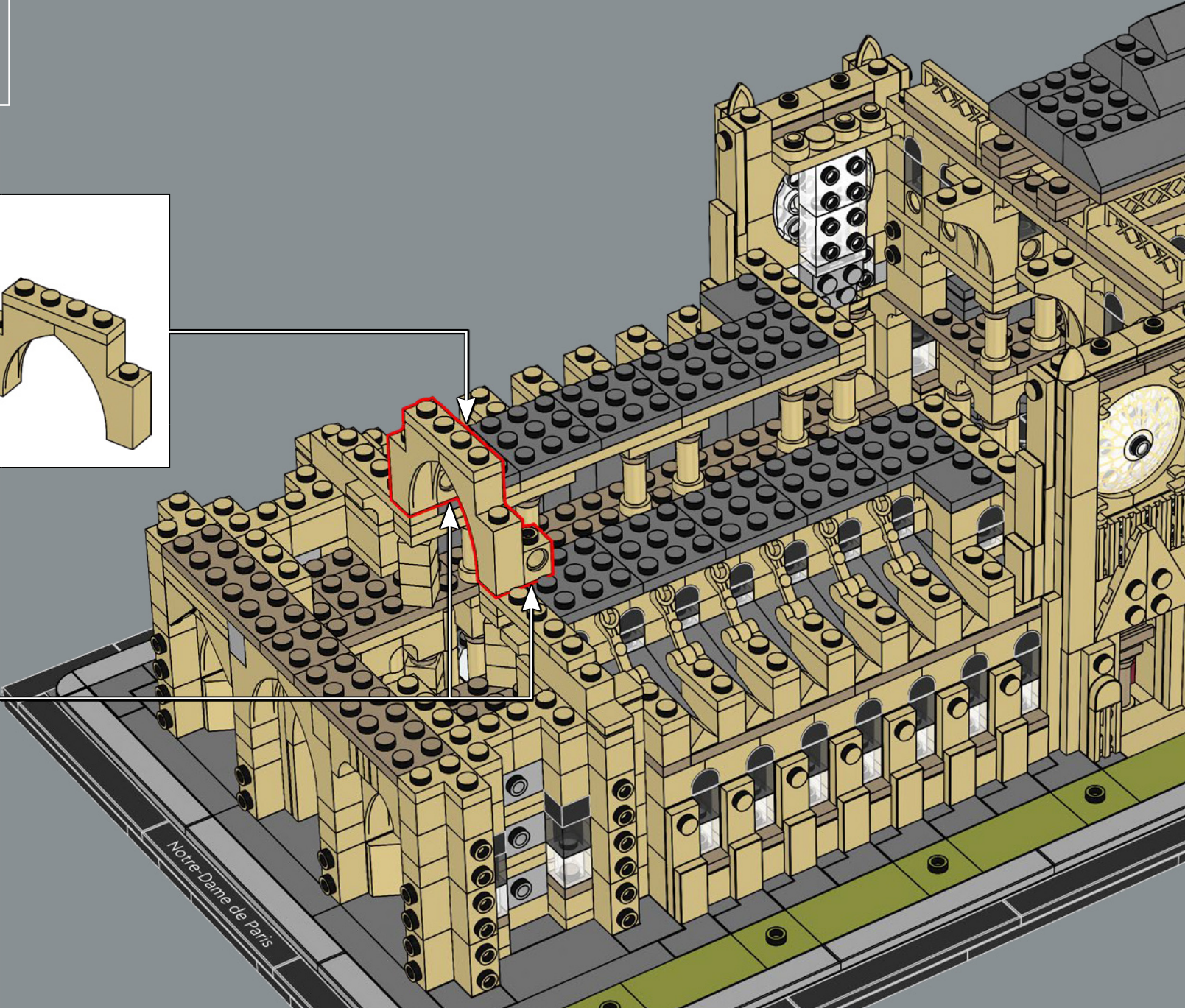
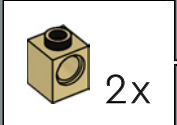
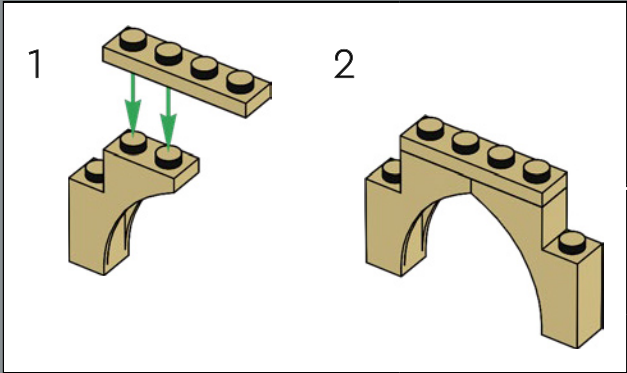

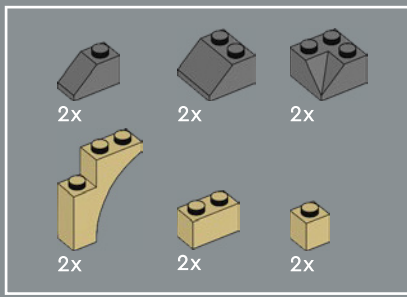

226

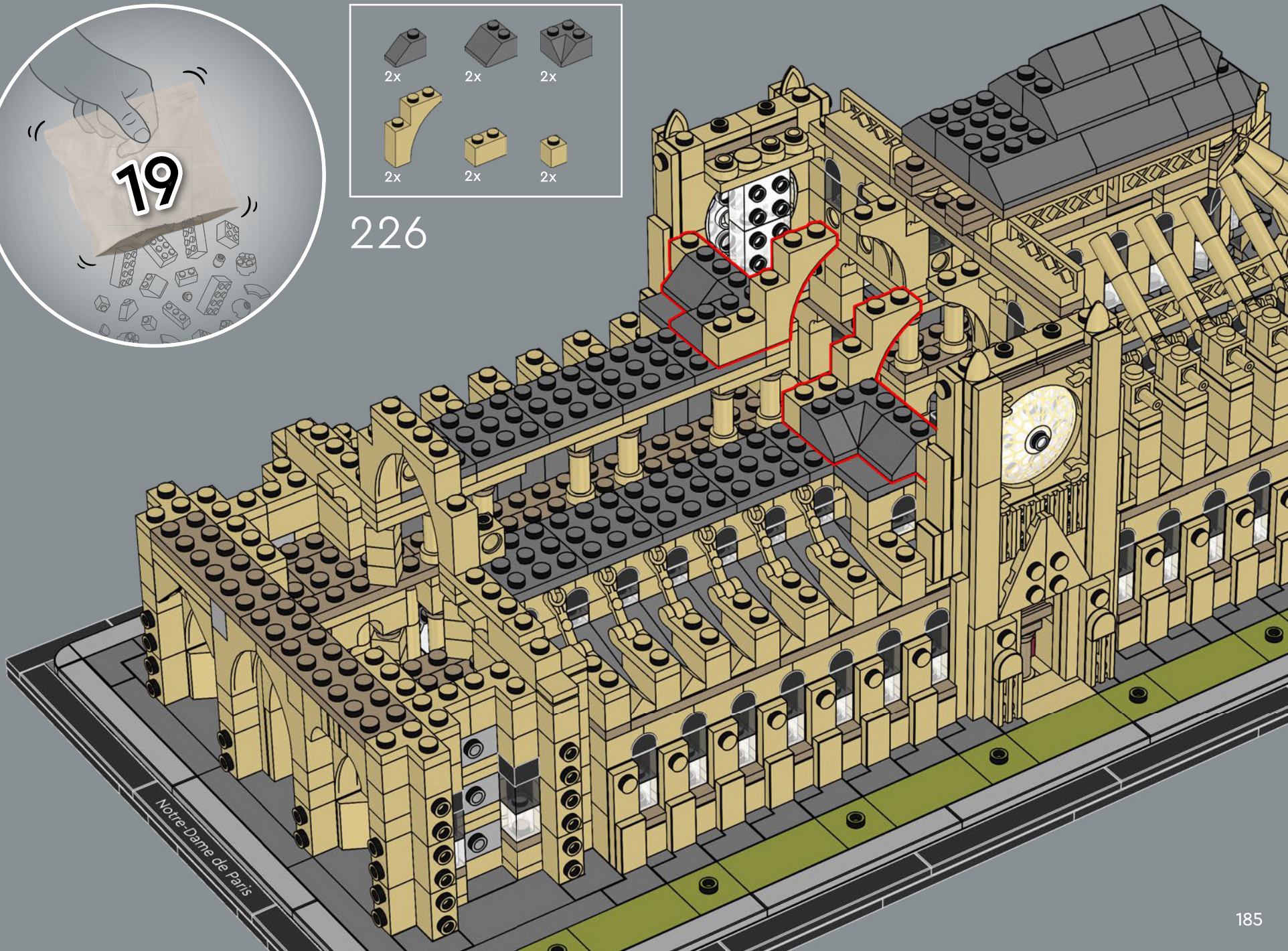



8x

227

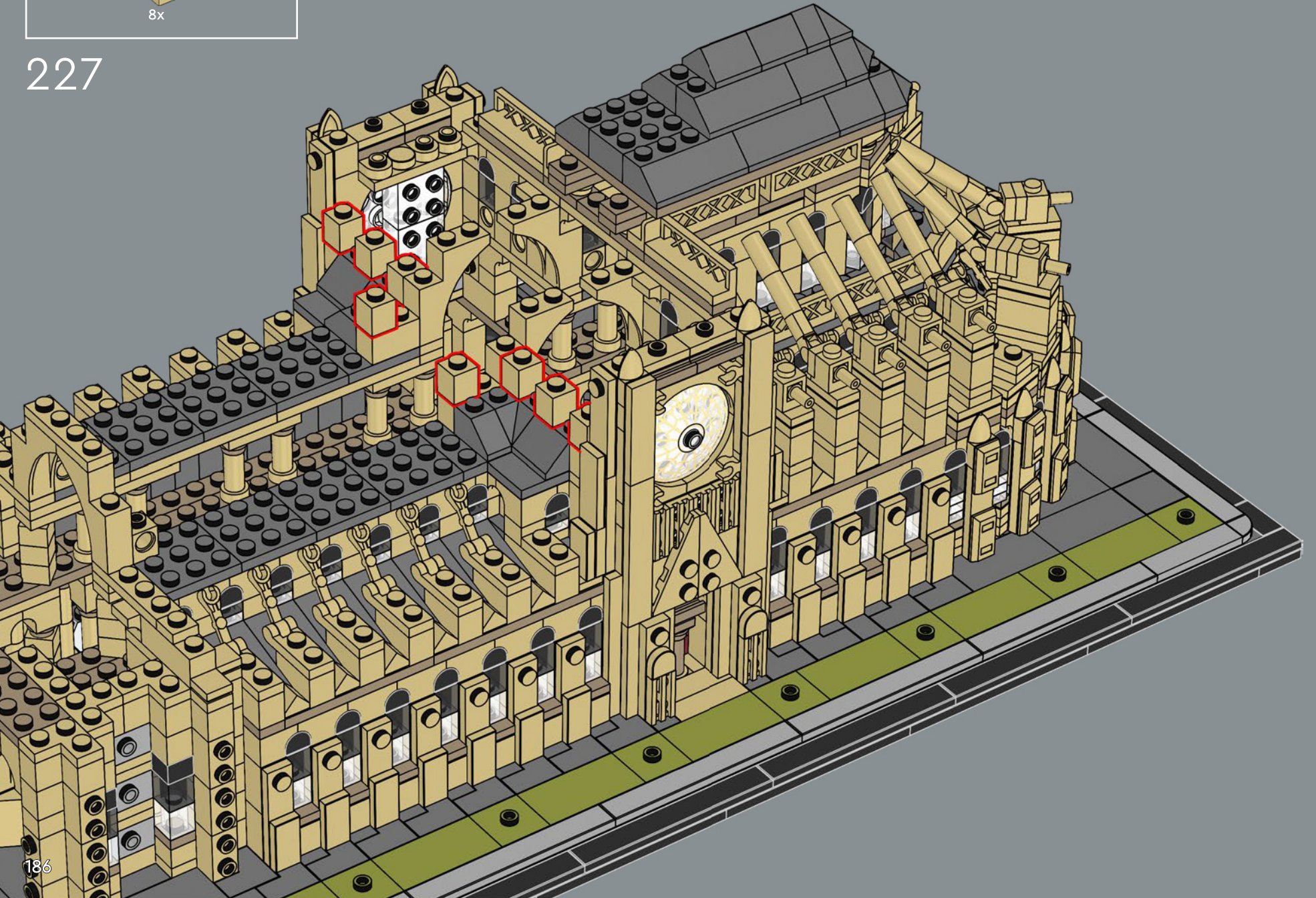

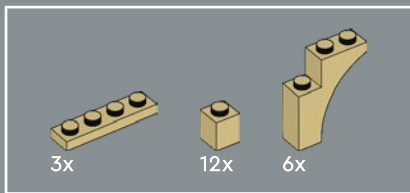

228

Les voûtes sont divisées en six parties par des arcs : ce sont les voûtes dites « sexpartites ». Le modèle LEGO® reste fidèle à l'original et présente un arc transversal reposant sur un chapiteau sur deux.

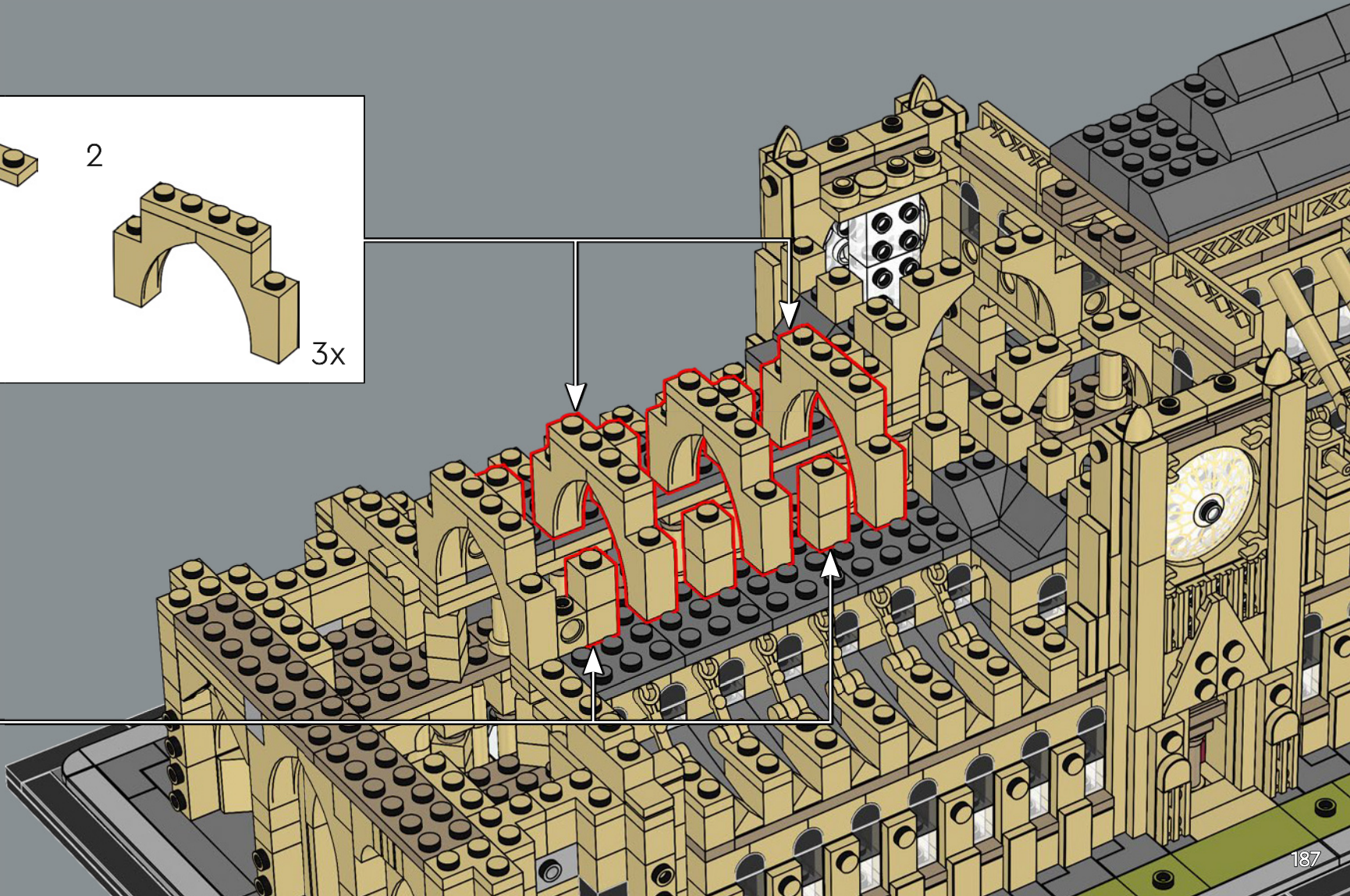
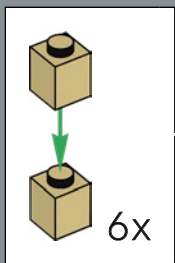
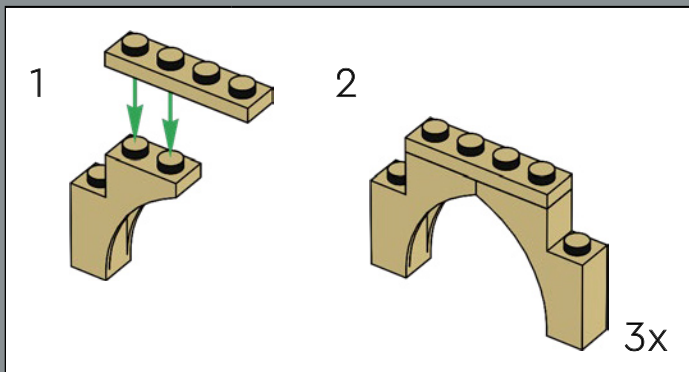



12x



20x



20x

229



8x



12x

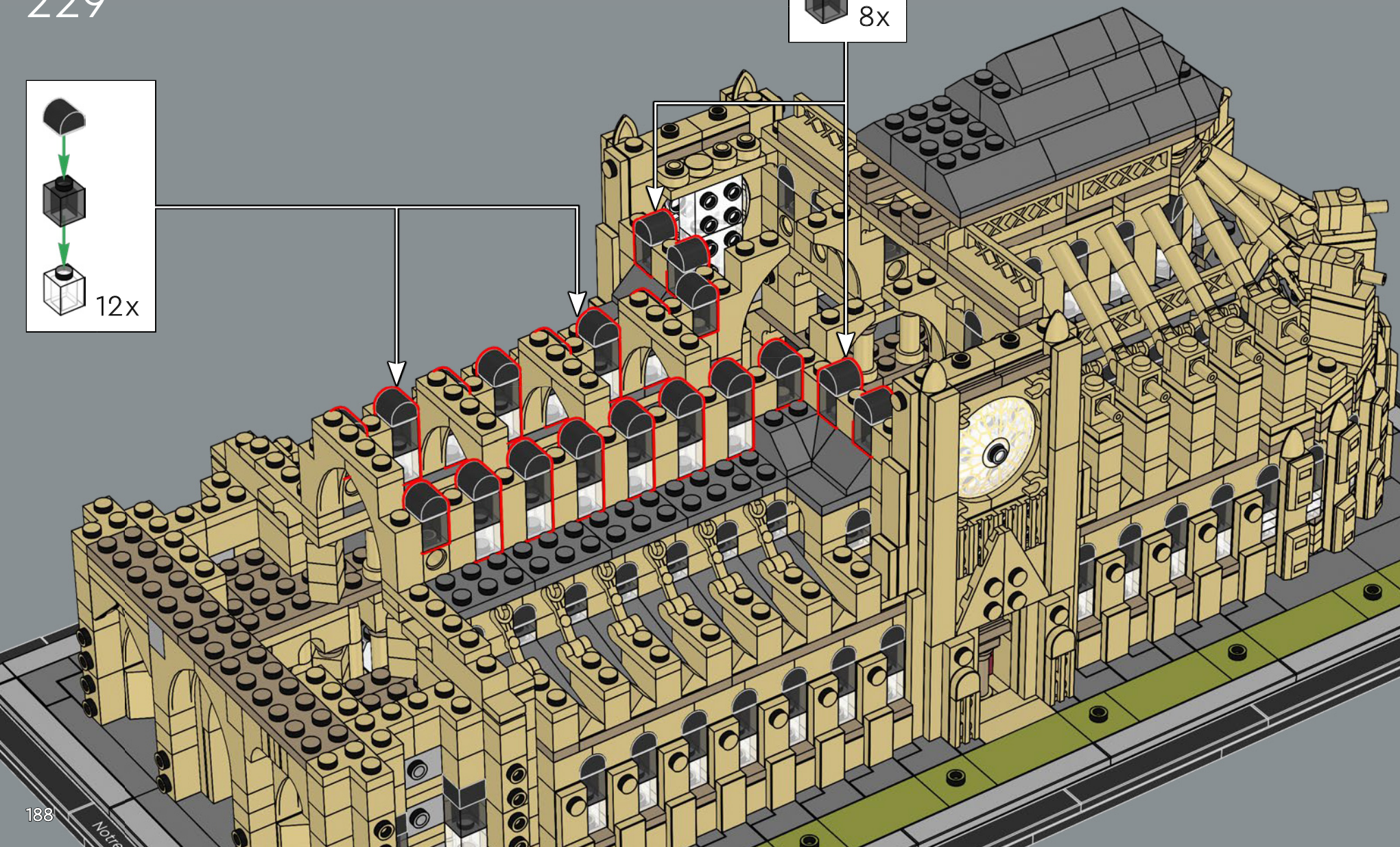

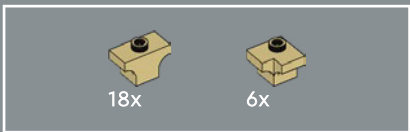

230

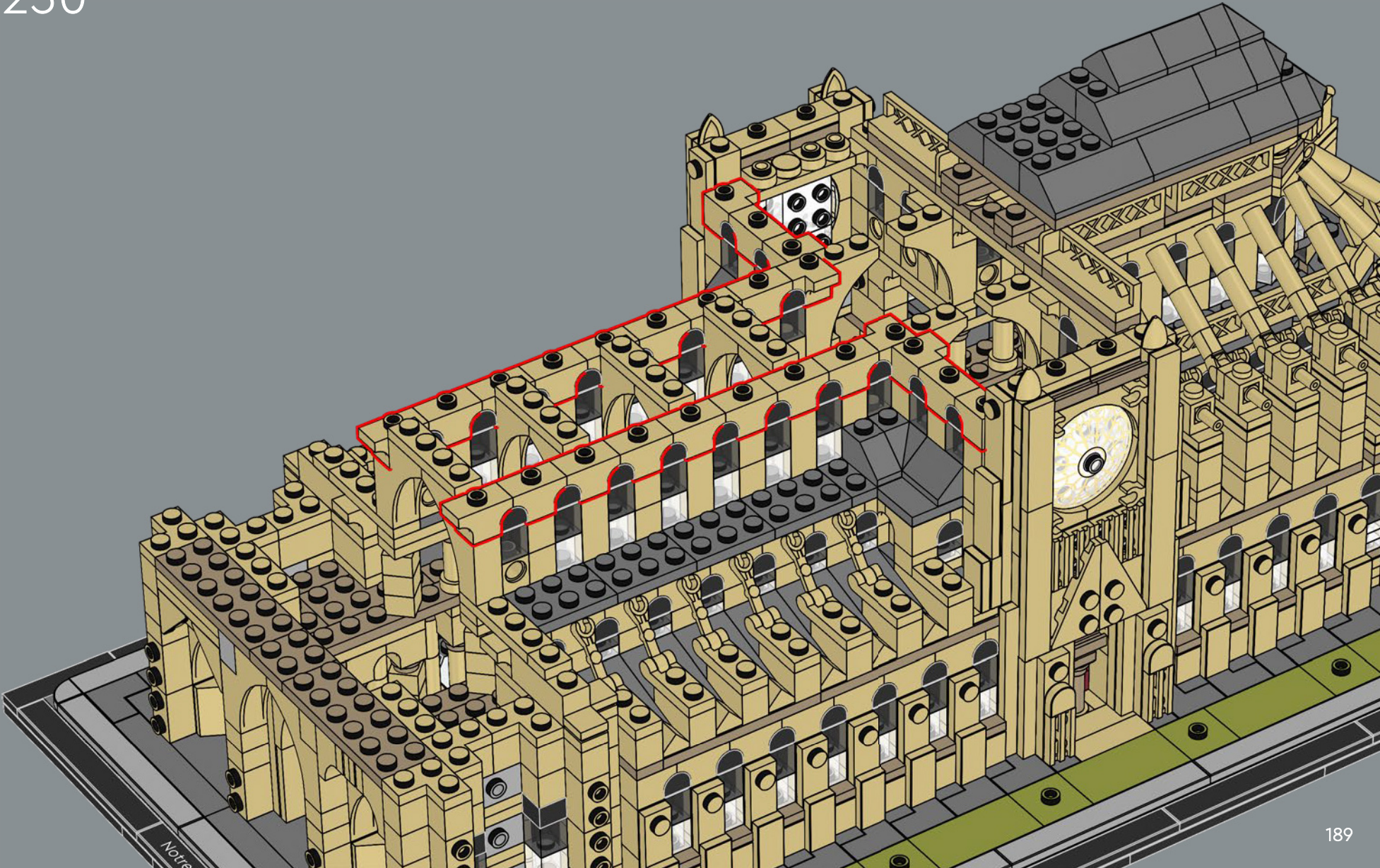

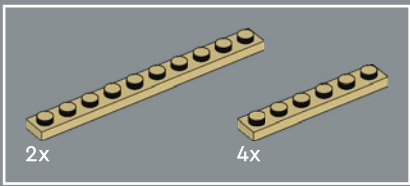

231

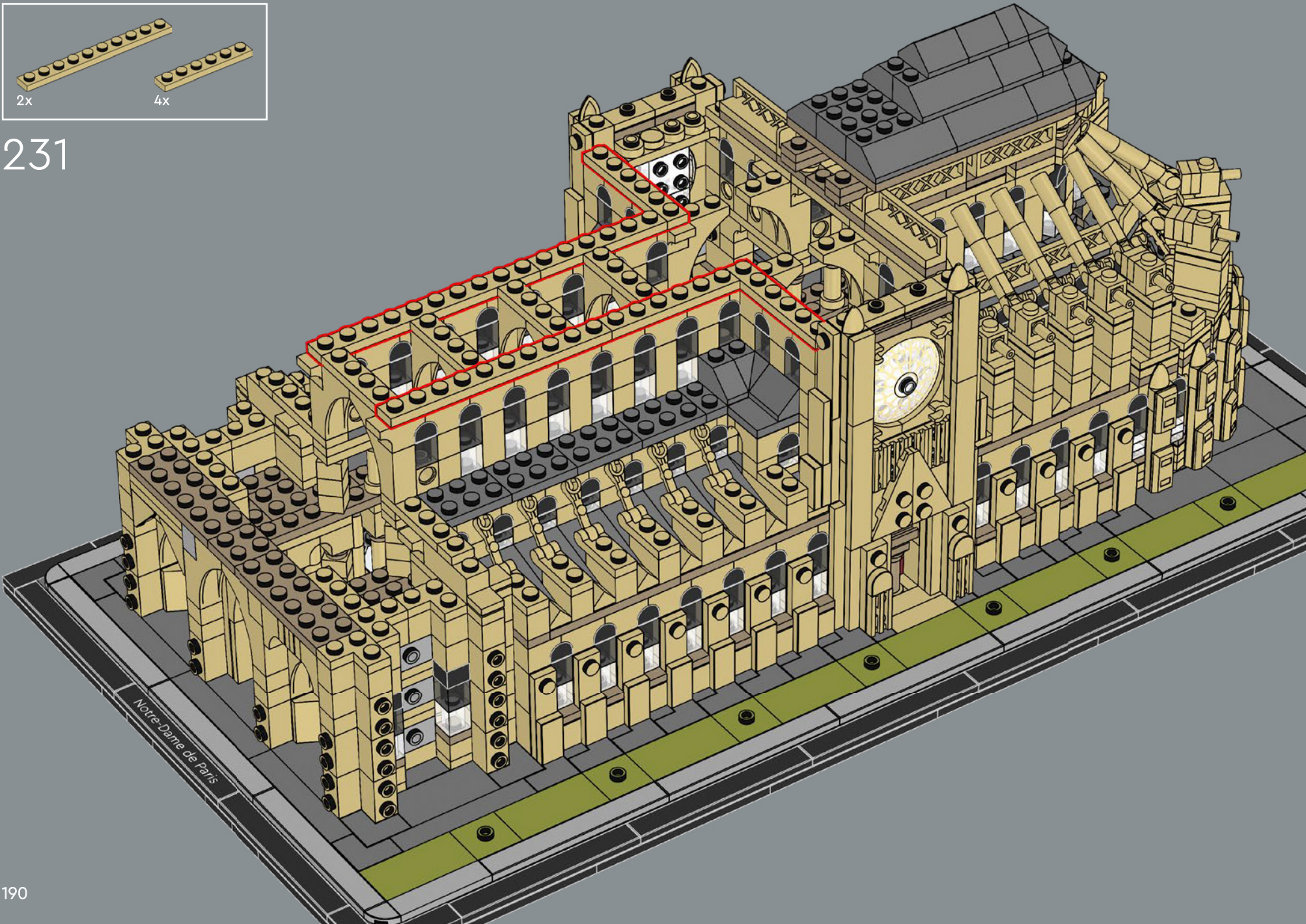

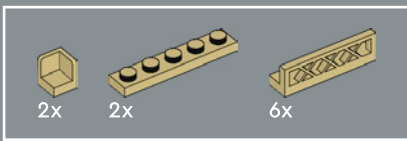

232

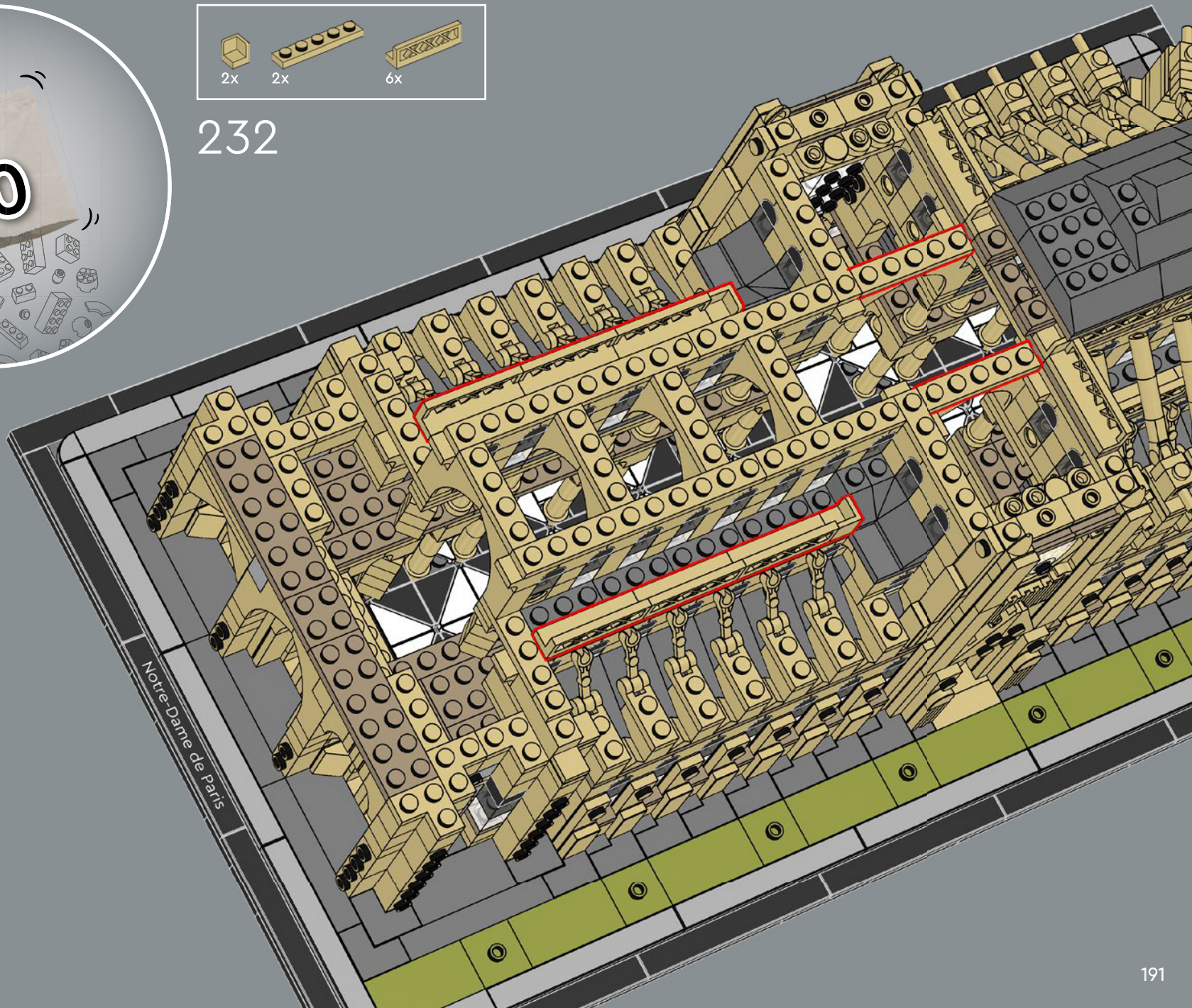

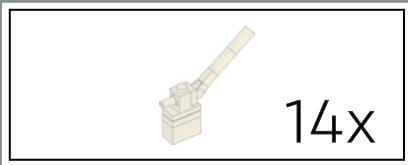

Les arcs-boutants de ce modèle LEGO® comportent des éléments percés, représentant les canalisations qui permettent d'évacuer l'eau des véritables arcs-boutants.

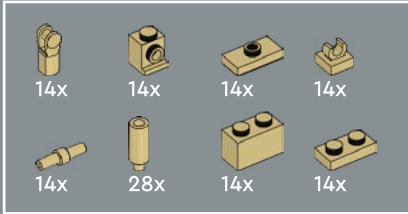

233

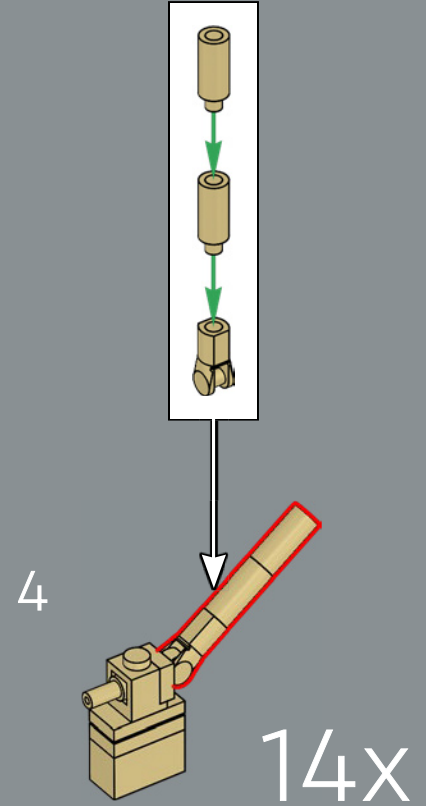
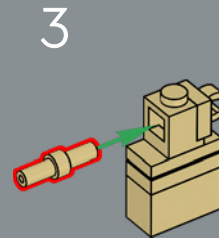
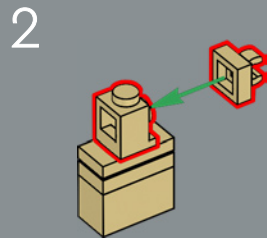
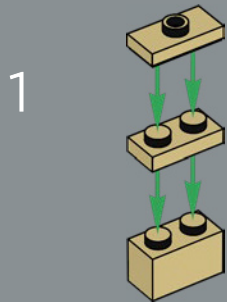

En 1225, les arcs-boutants de la nef sont équipés de canalisations qui évacuent l'eau de pluie du toit à travers les gargouilles.

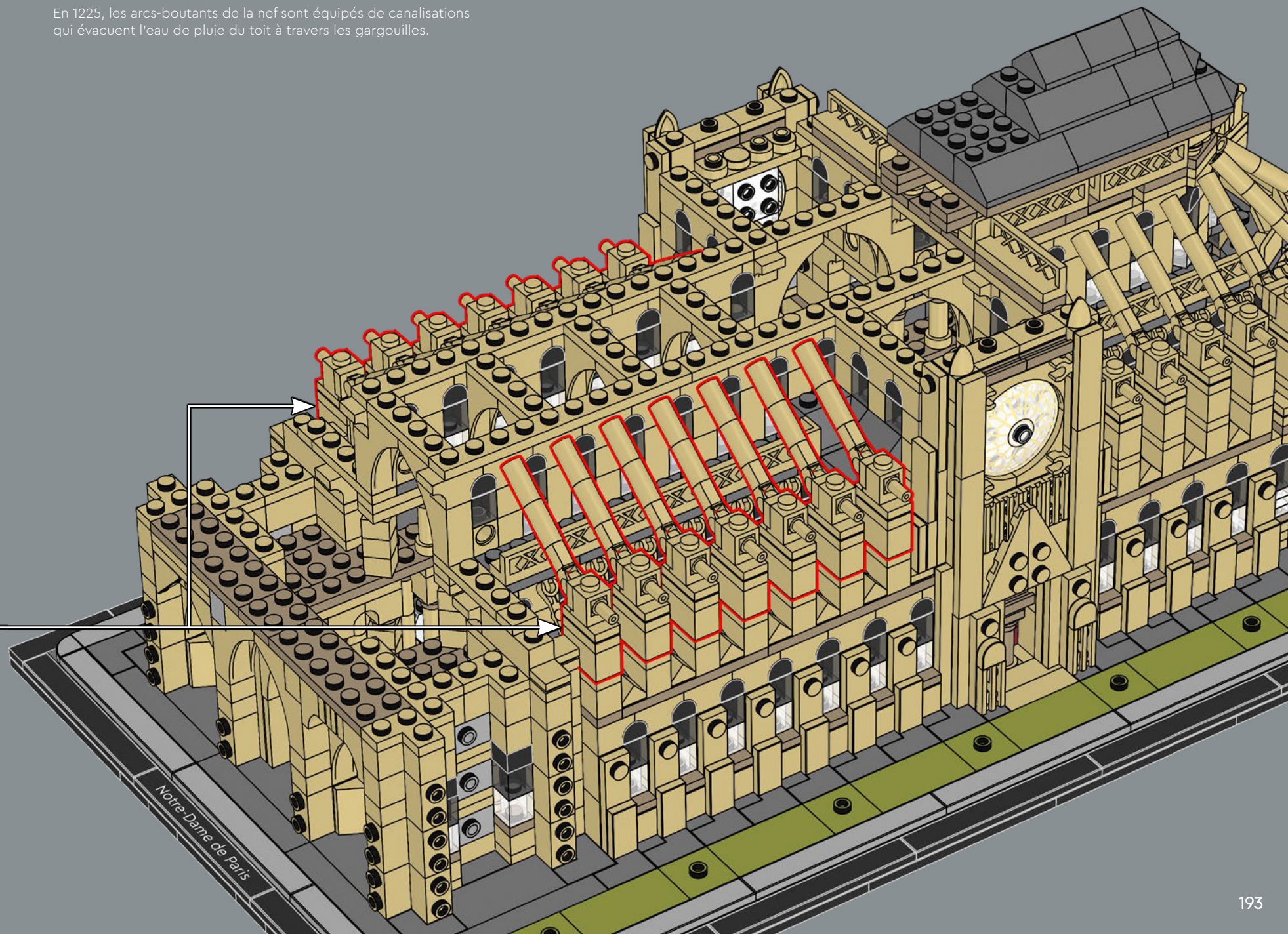

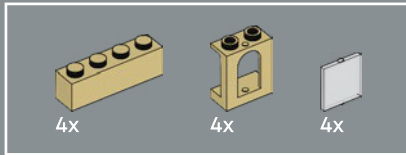
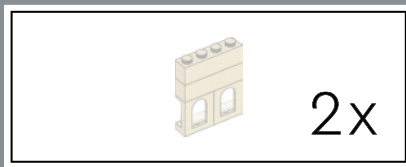

234

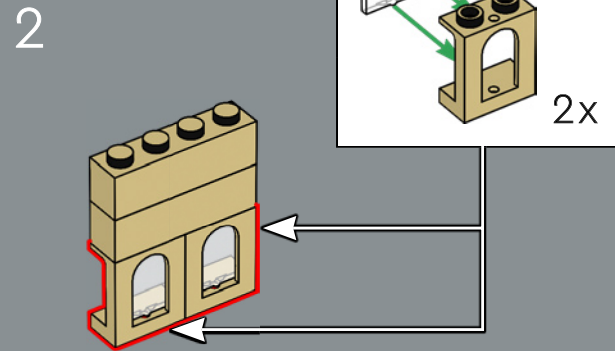
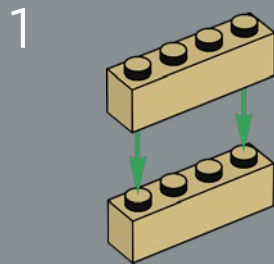

2x

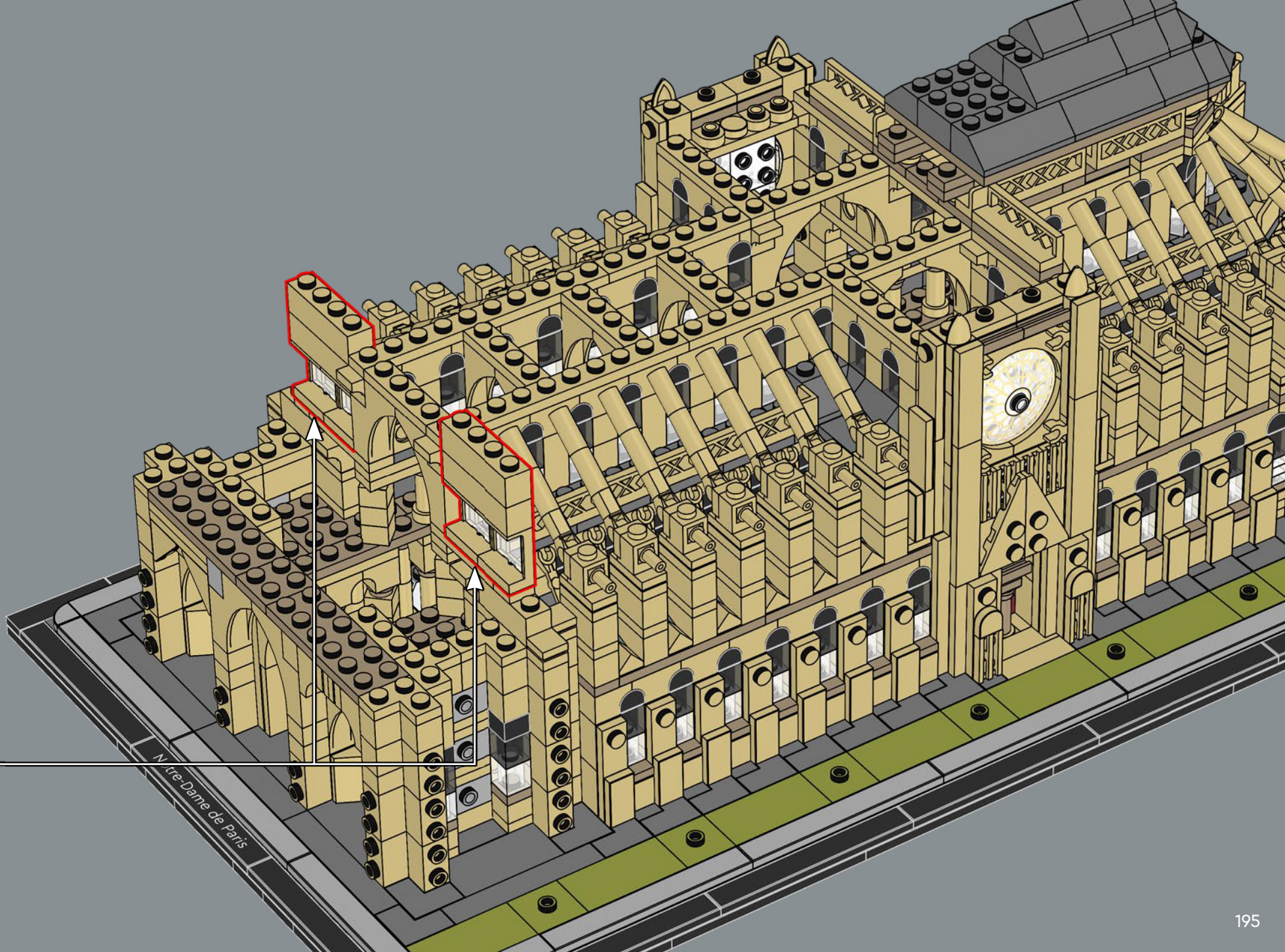

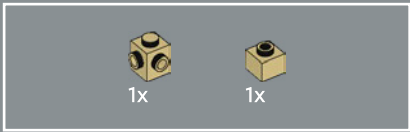

235

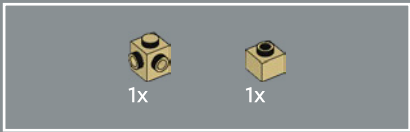
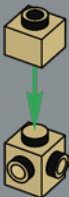

236



237

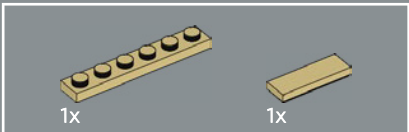

238

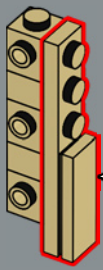
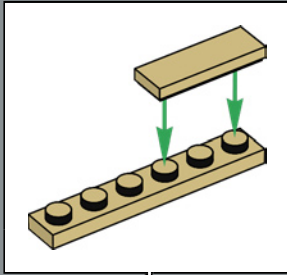

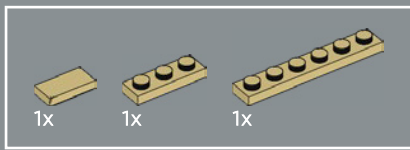

239

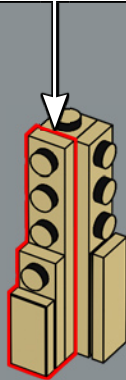
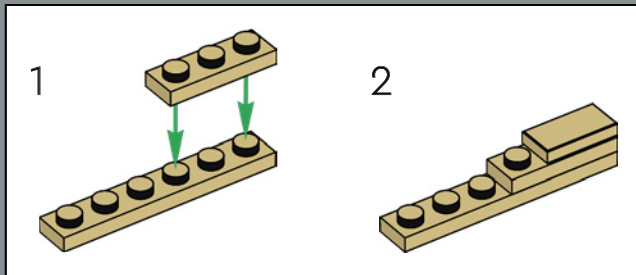

240

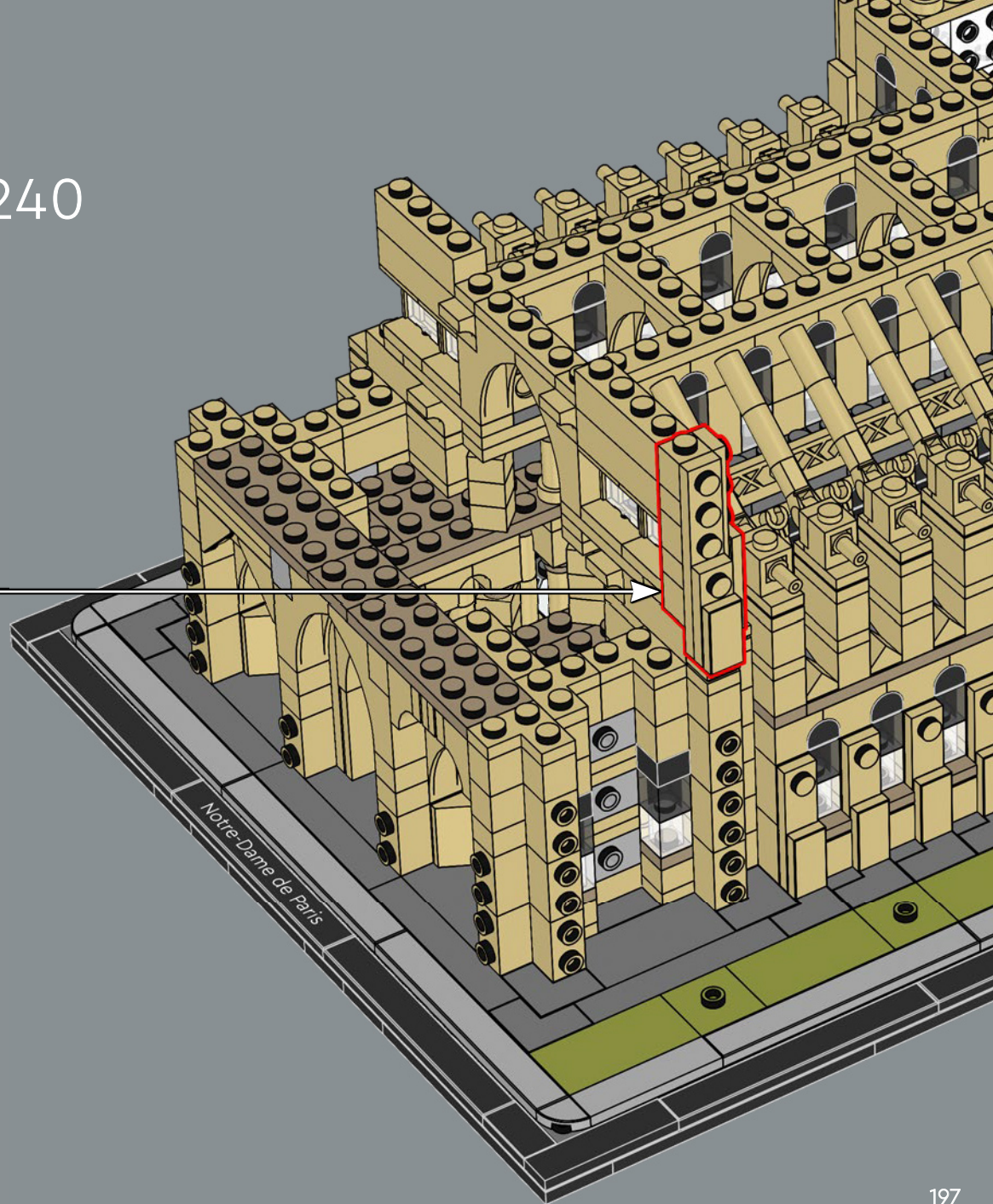

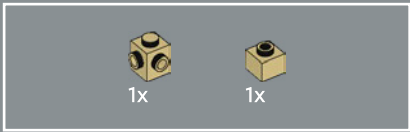

241

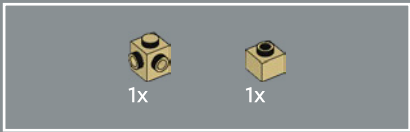
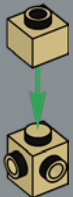

242



243

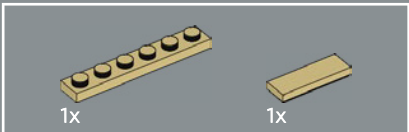

244

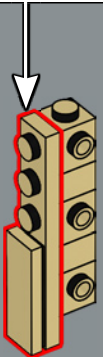
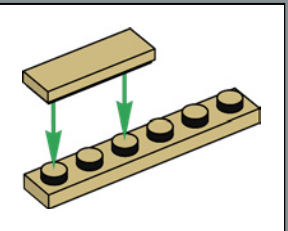

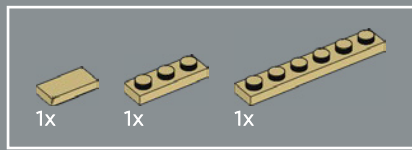

245

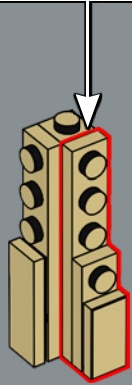
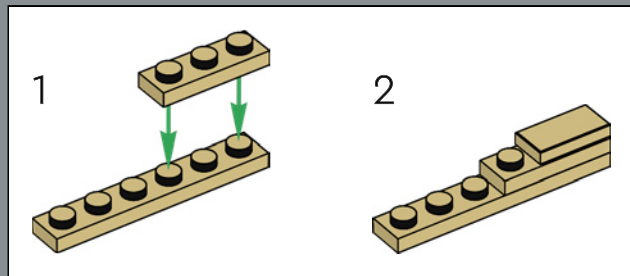

246

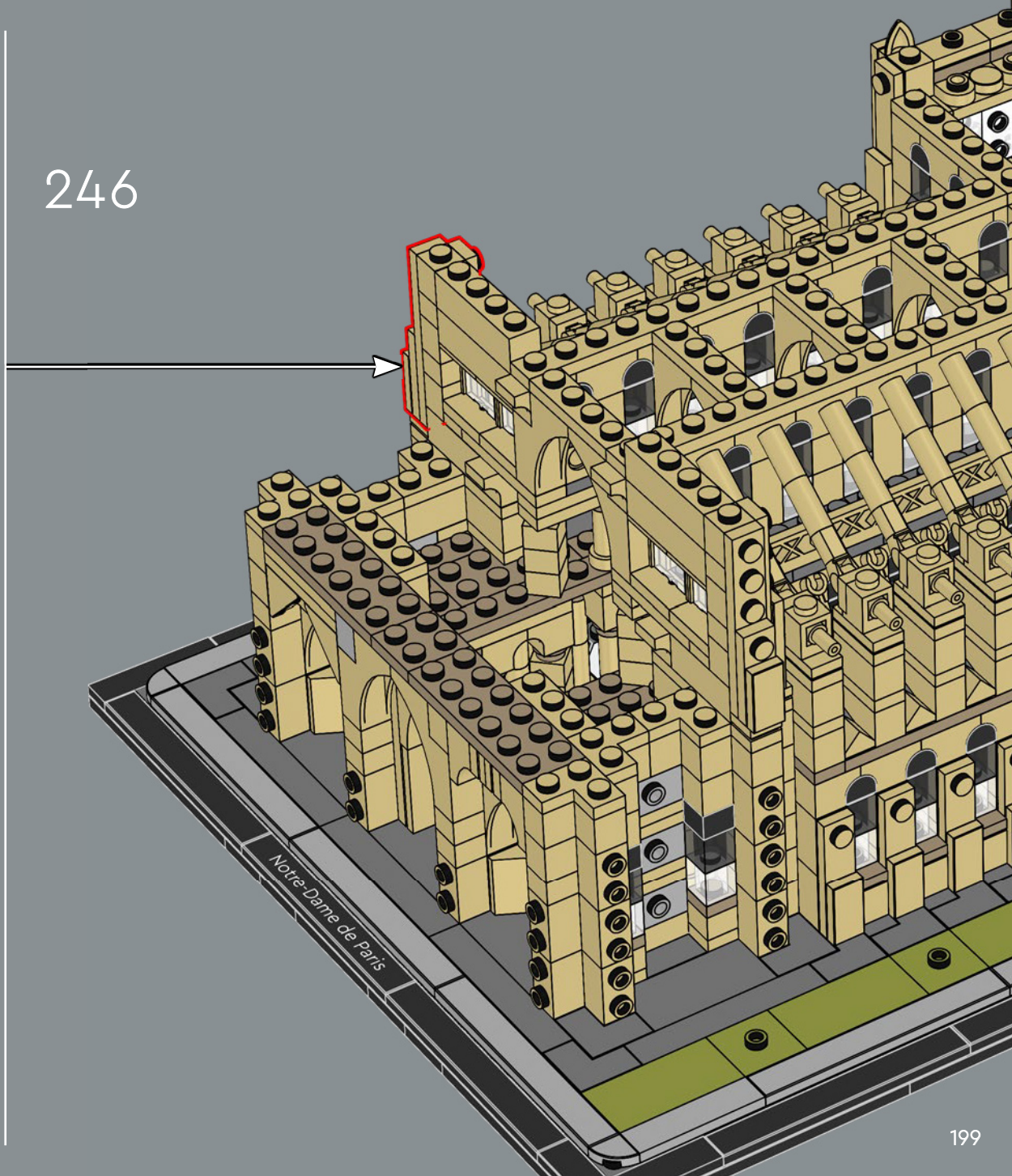



247

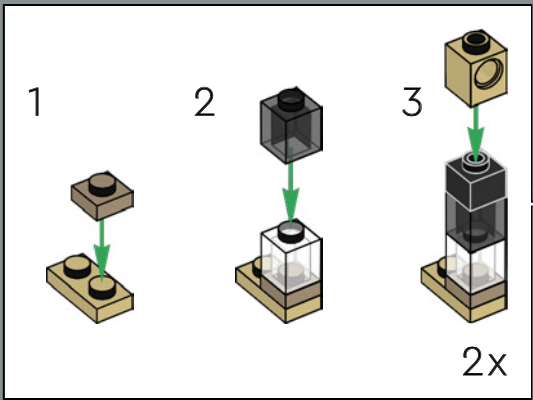

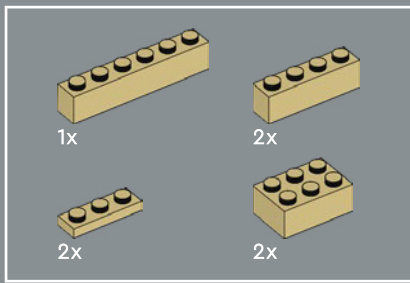

248

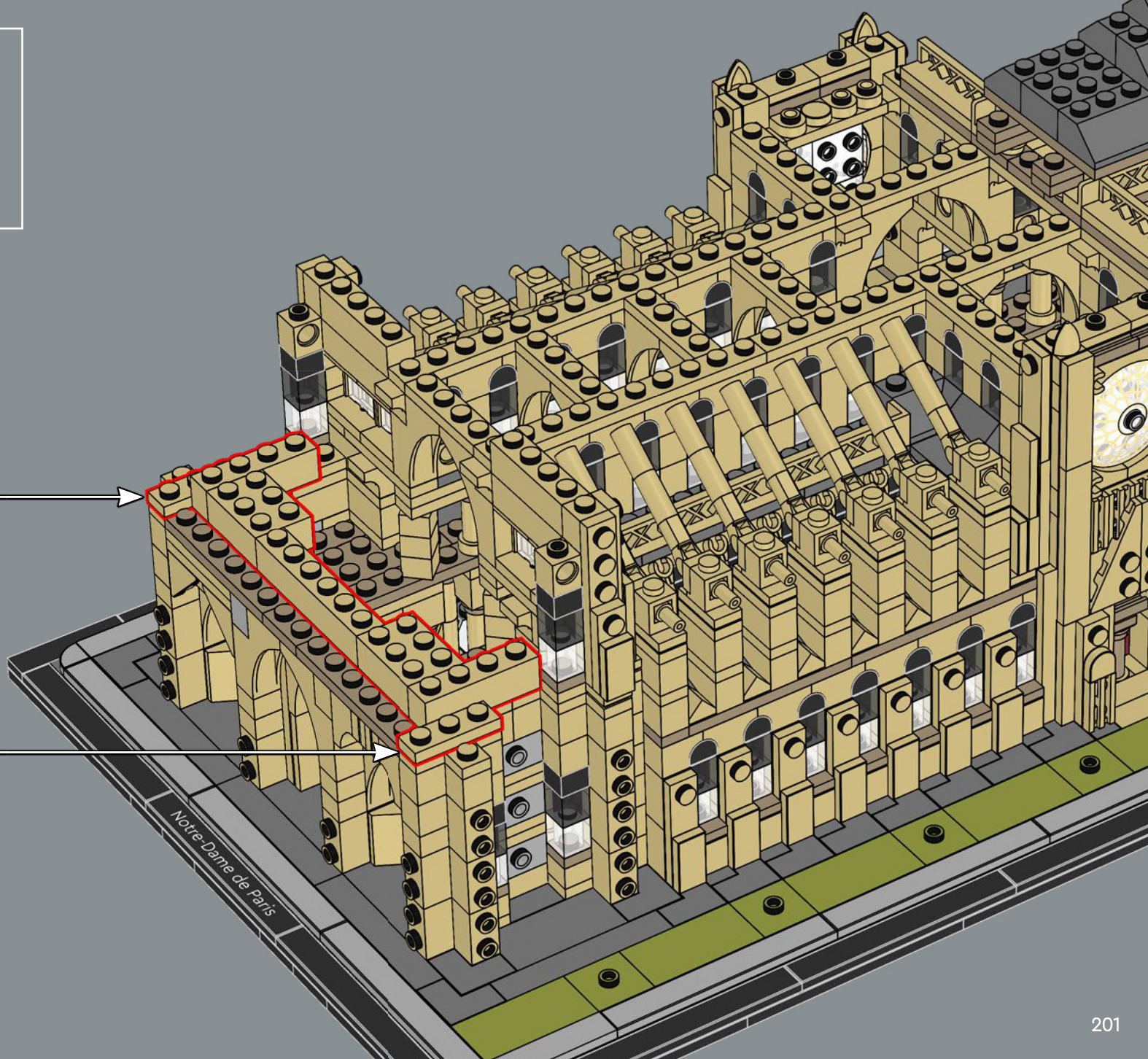
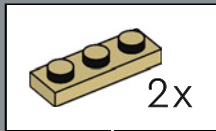

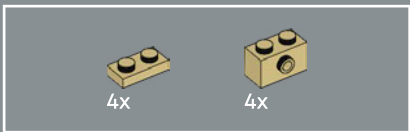

249

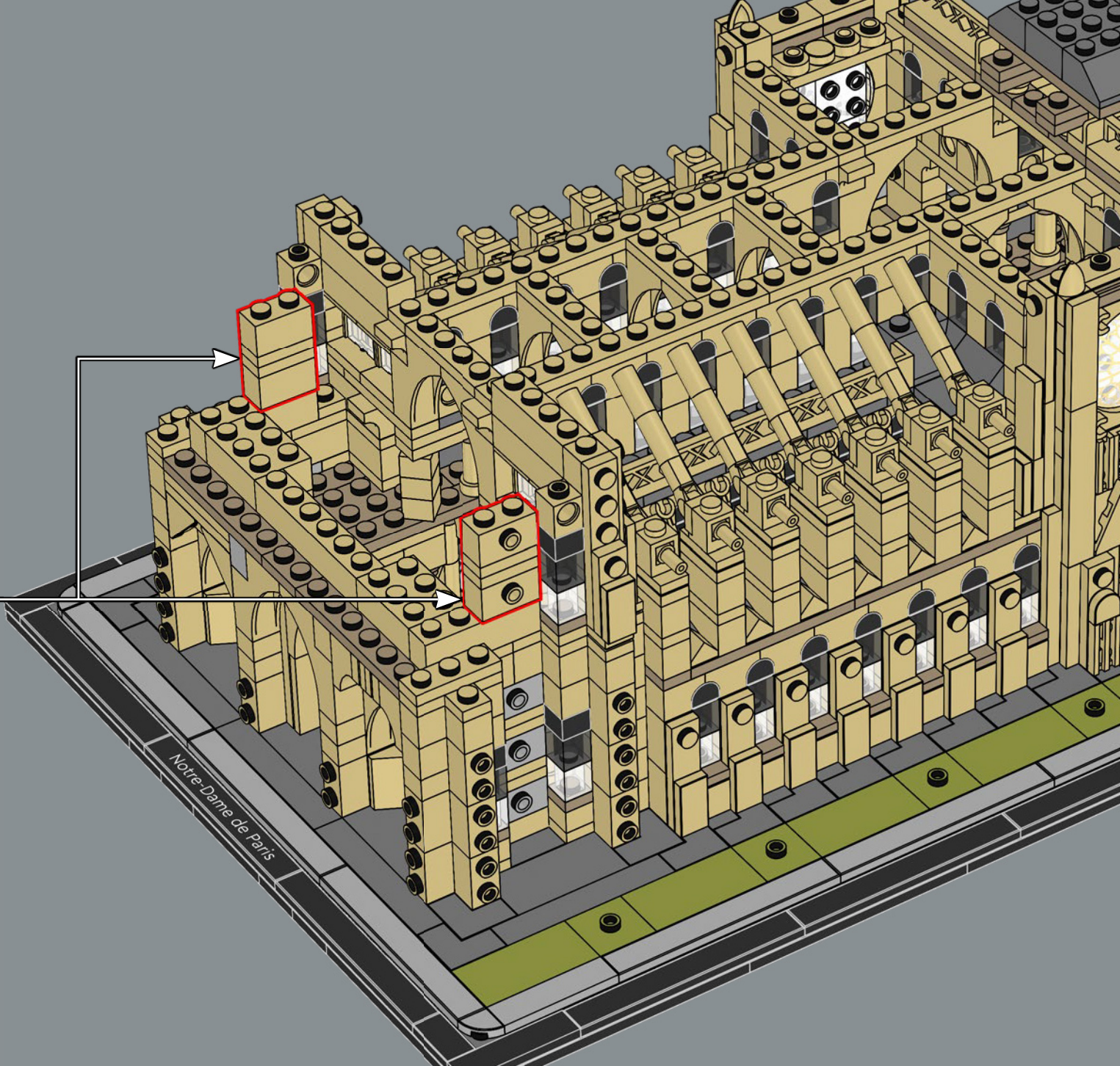
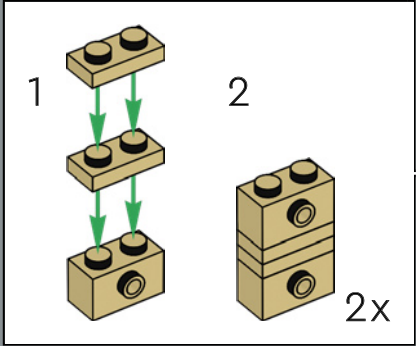

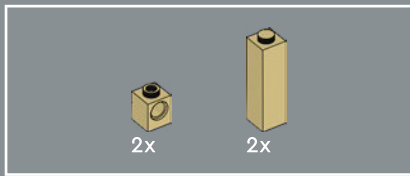

250

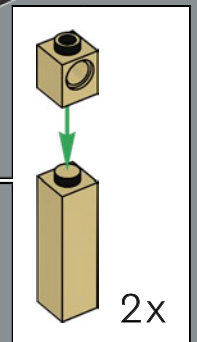
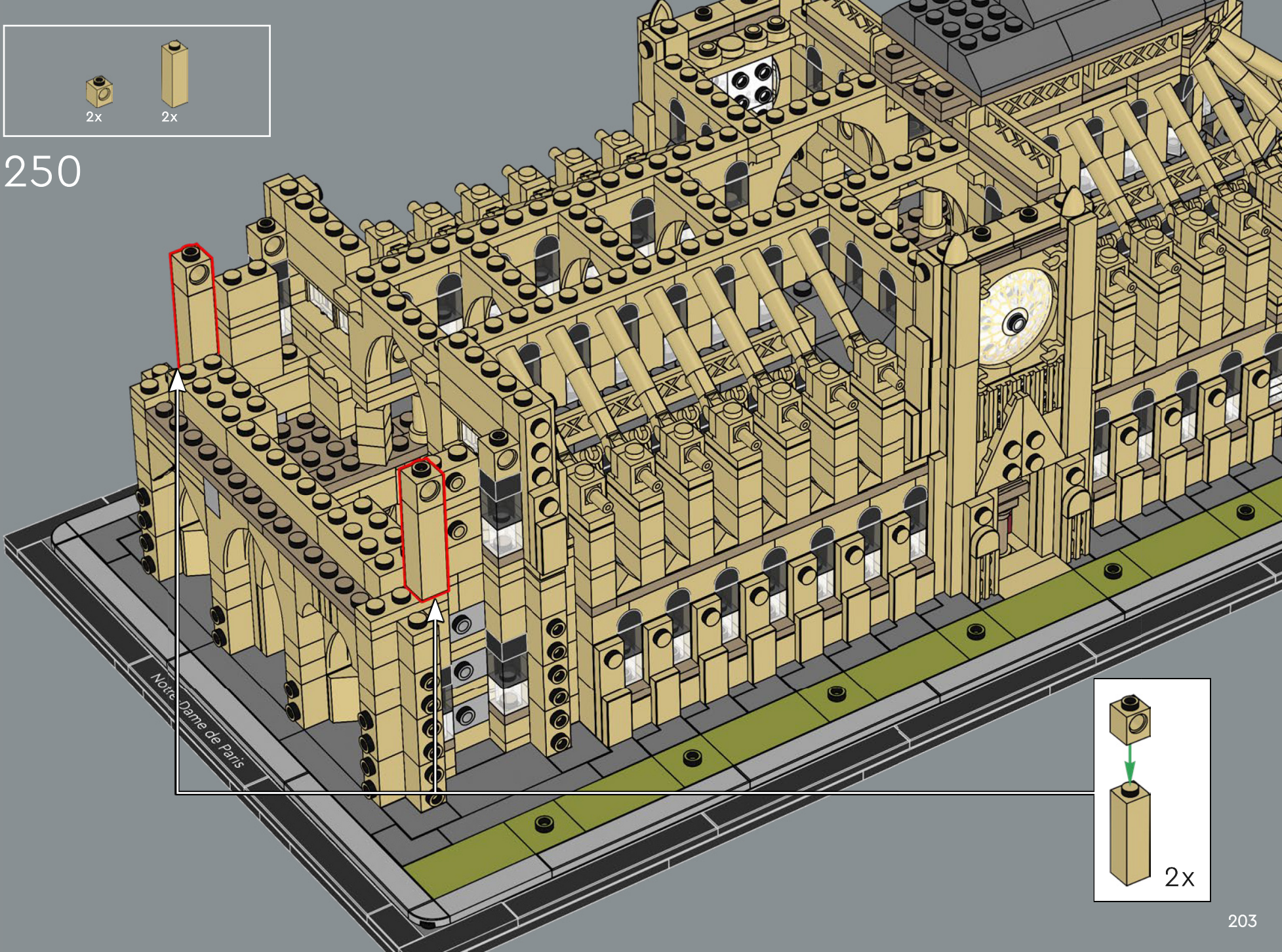

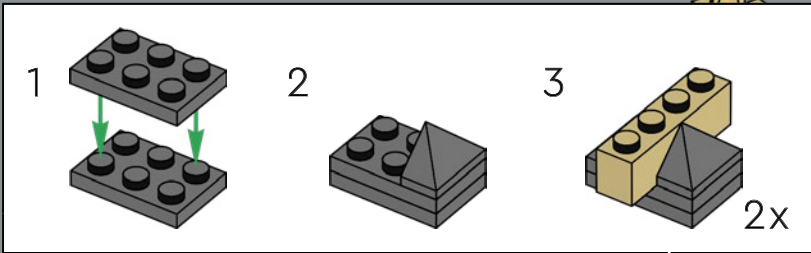
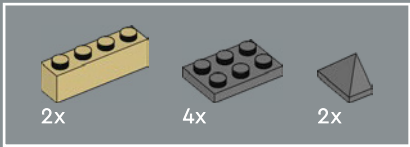

251

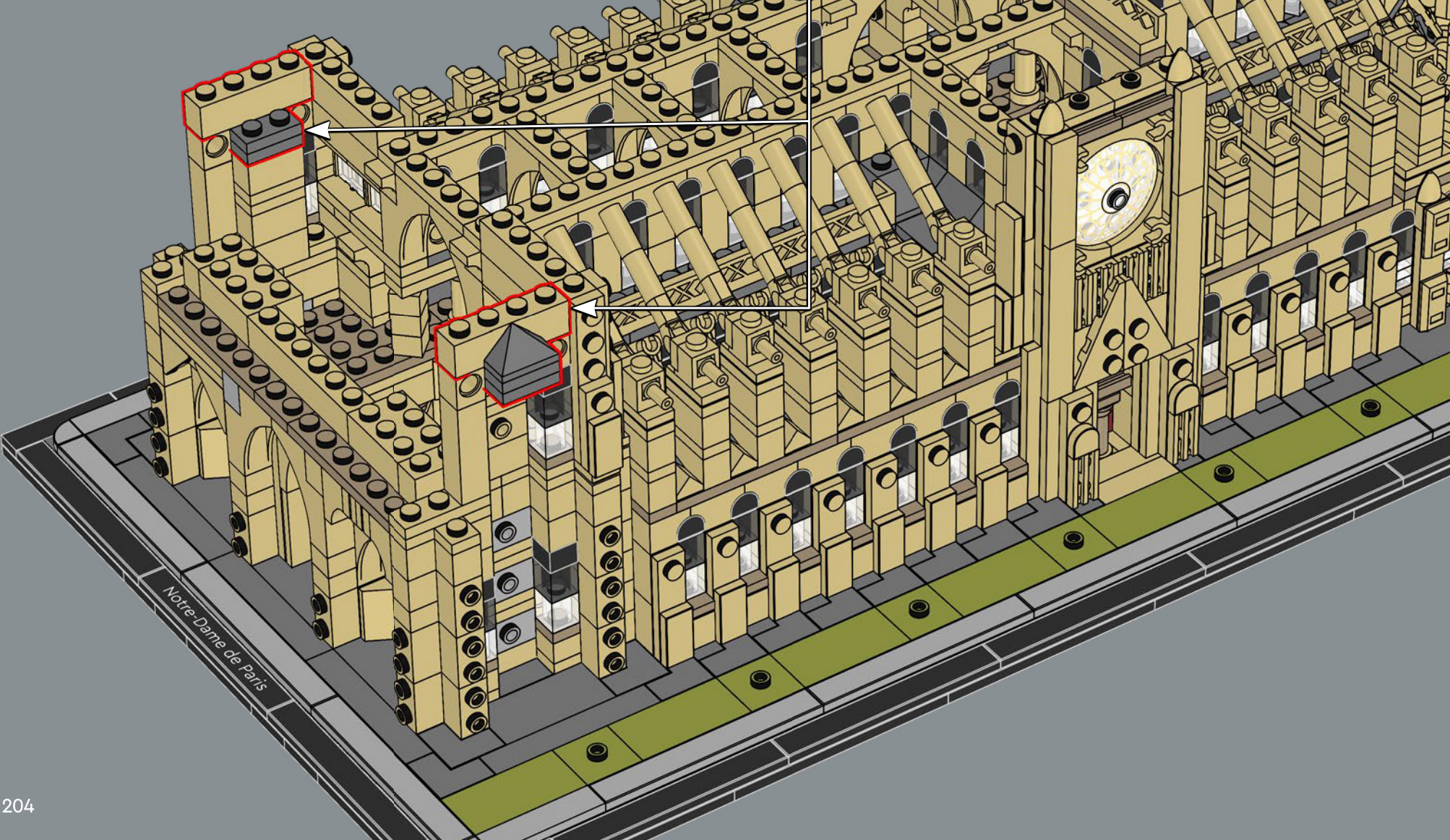

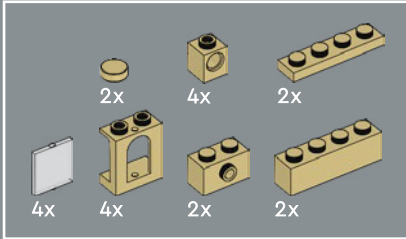
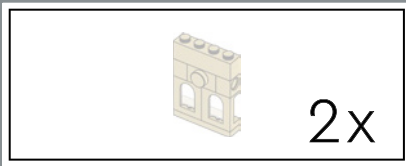

252

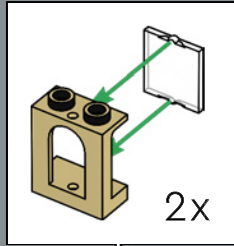

1

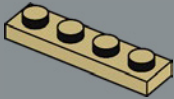

2

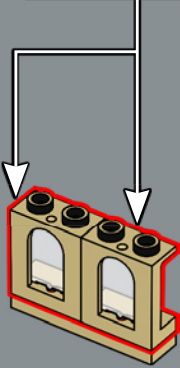

3

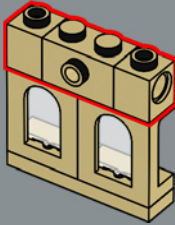

4

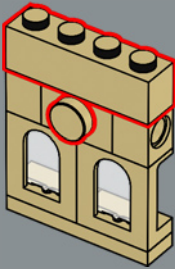

2x

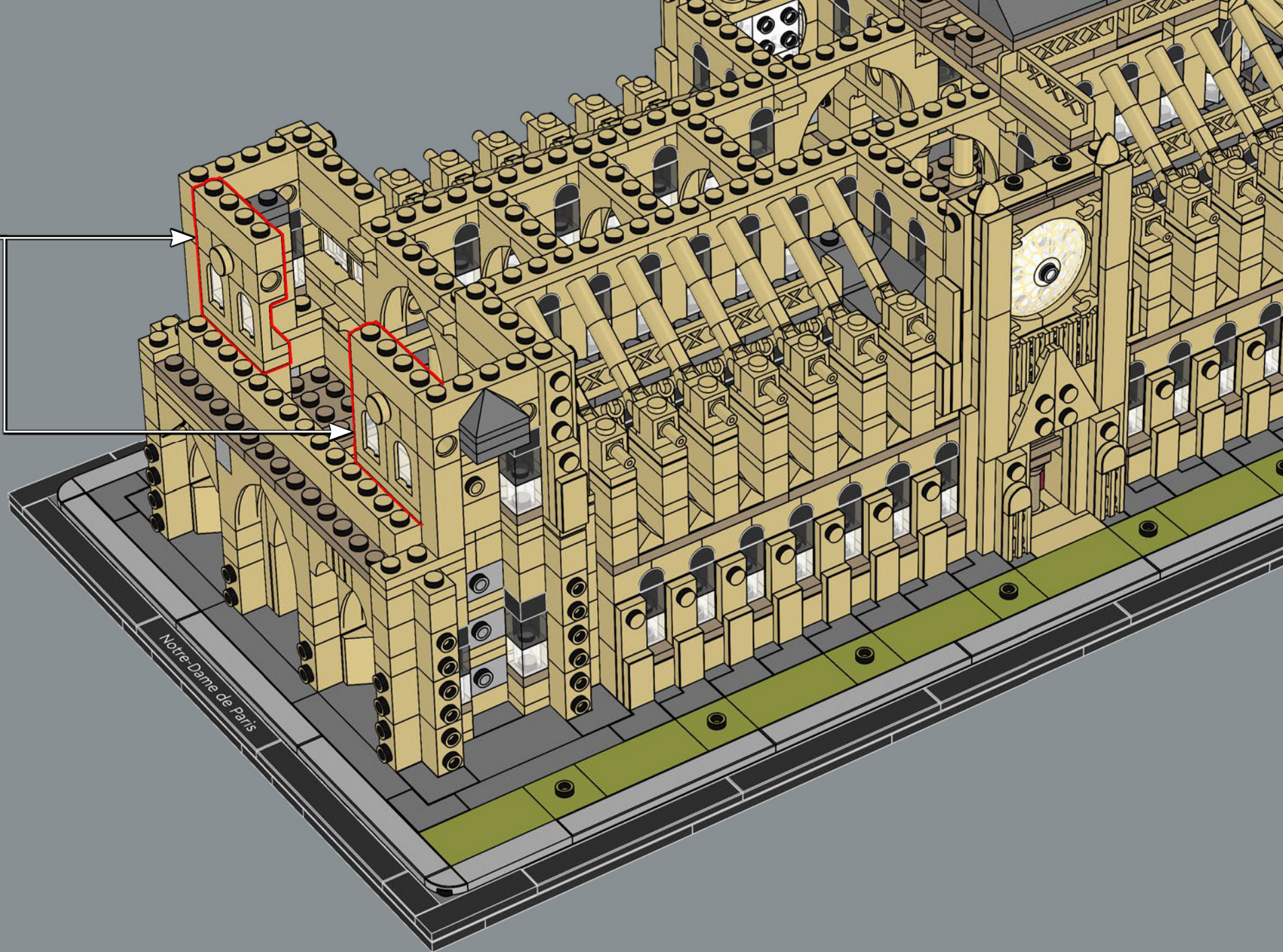

Notre-Dame de Paris

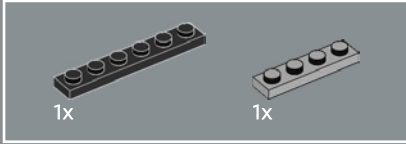
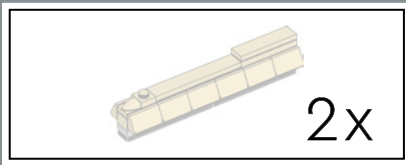

253

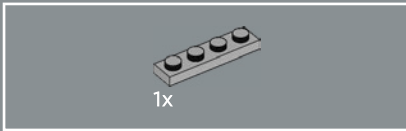
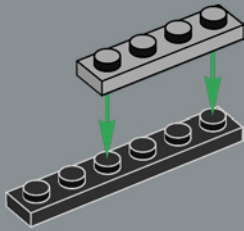

254

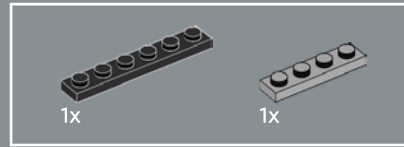
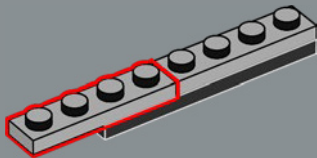

255

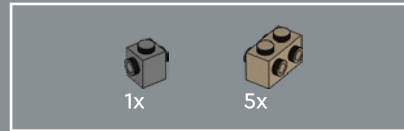
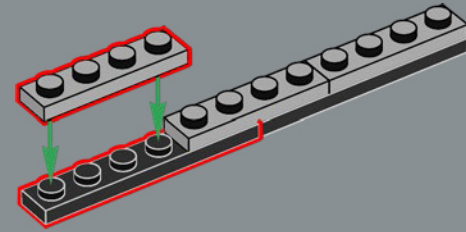

256

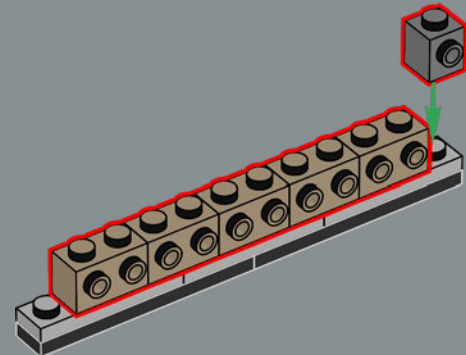

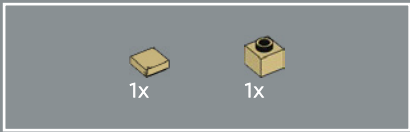

257

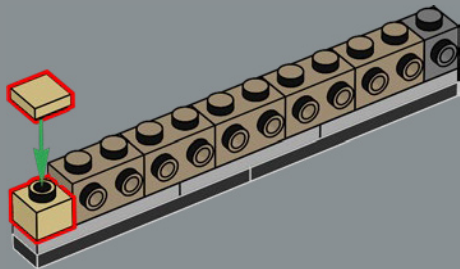

258

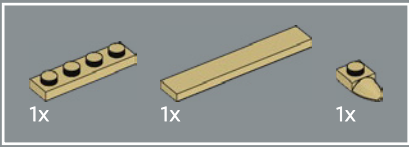
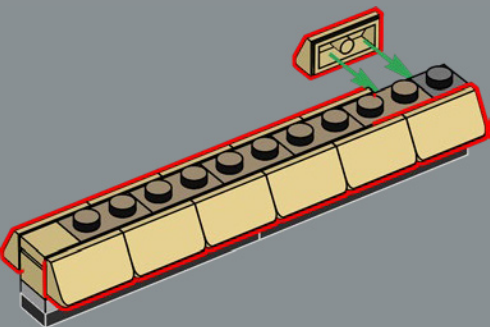

259

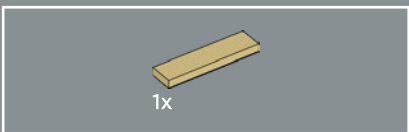
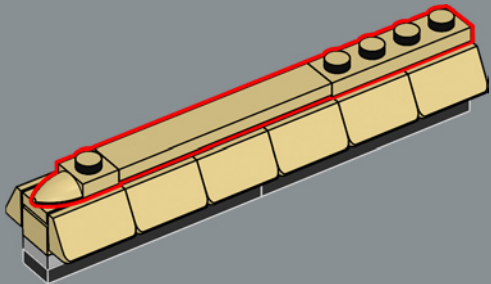

260

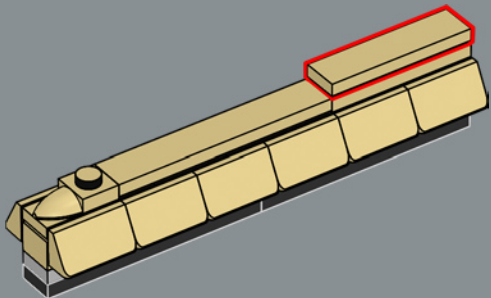

2x

261



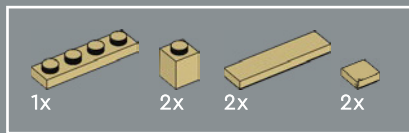

262

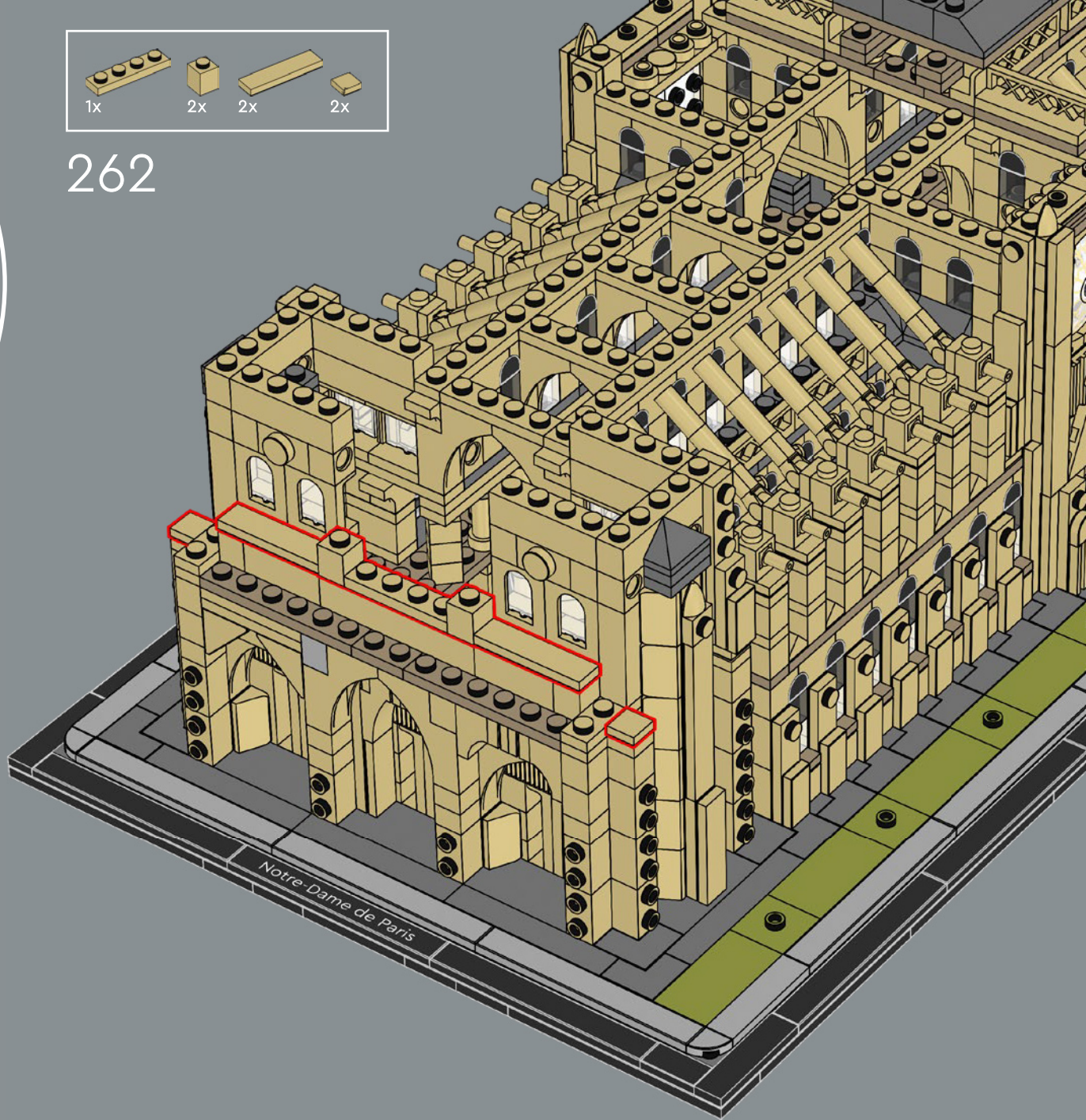



263



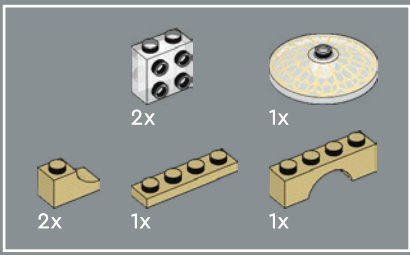

264

1

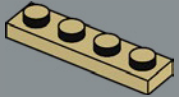

2

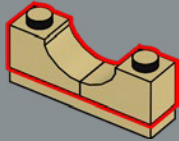

3

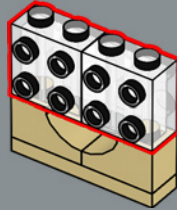

4

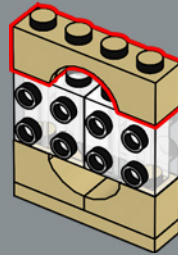

5



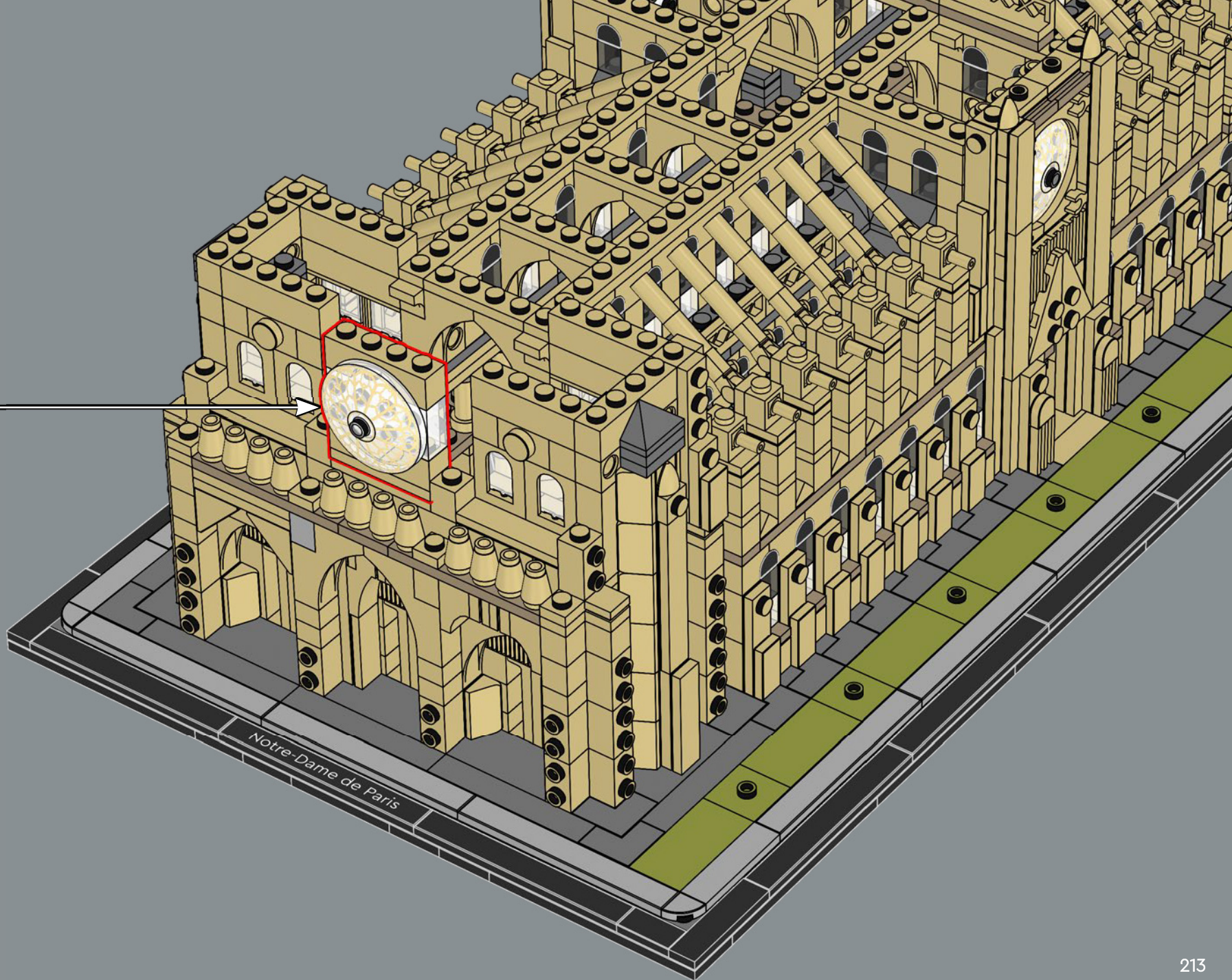

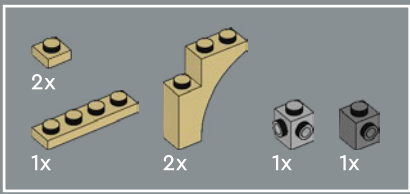

265

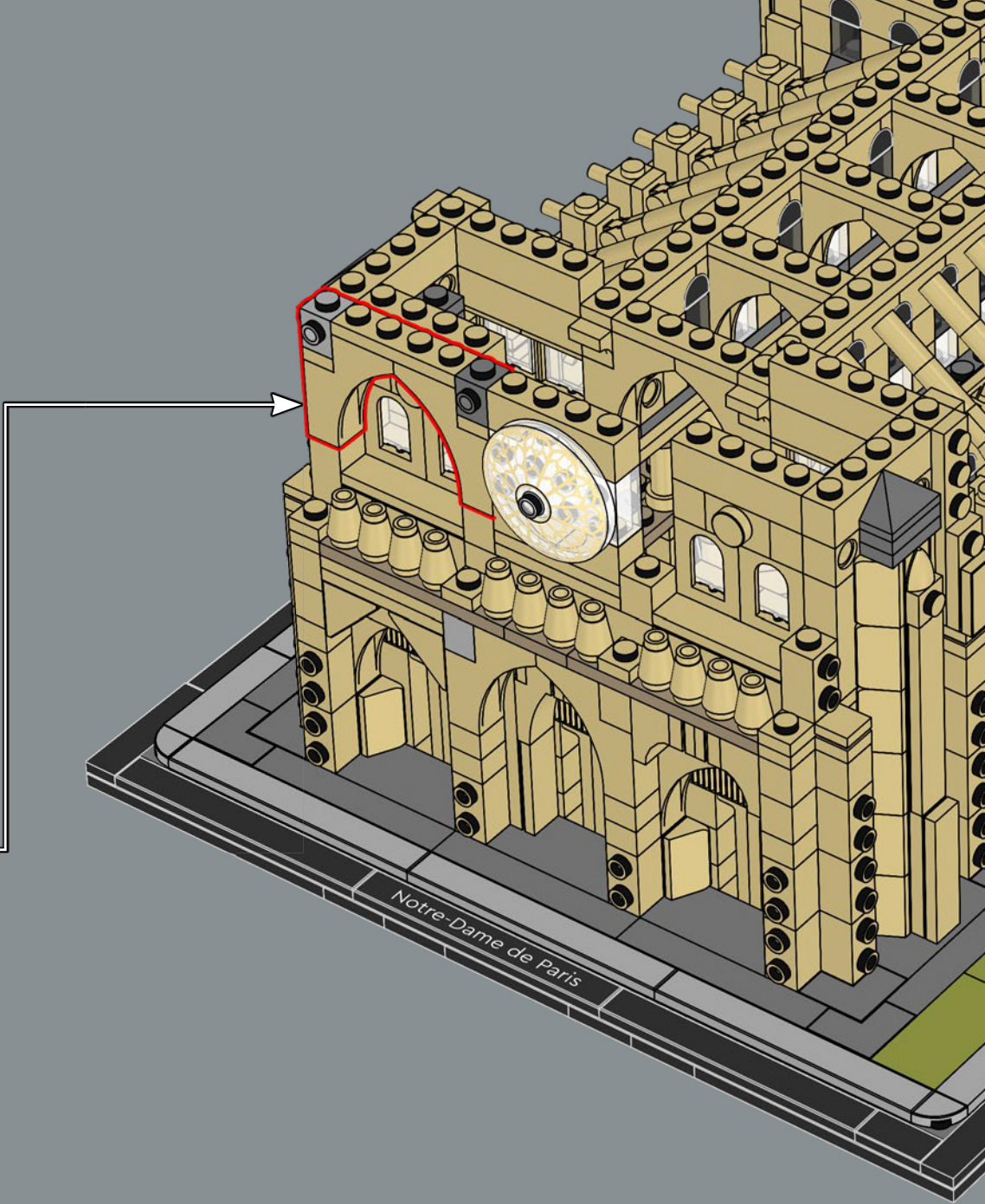
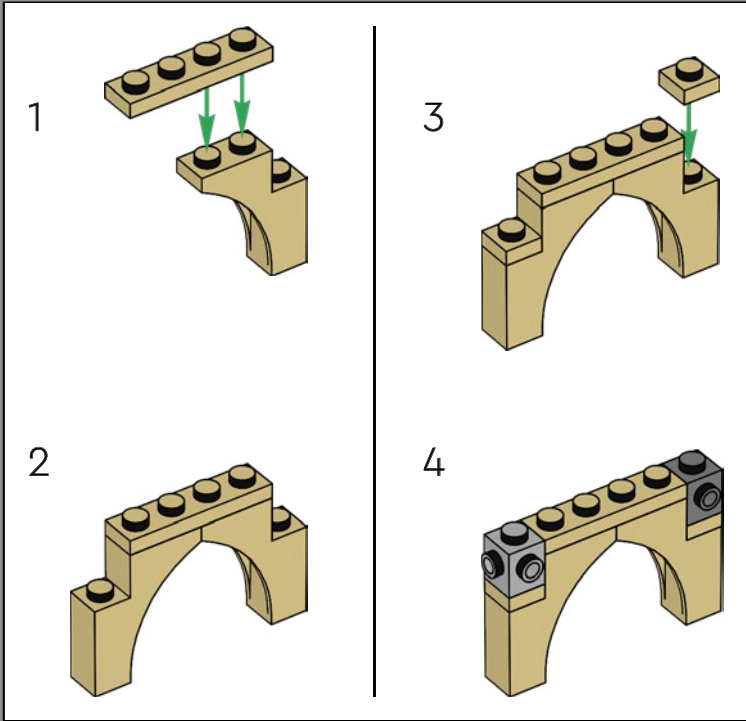

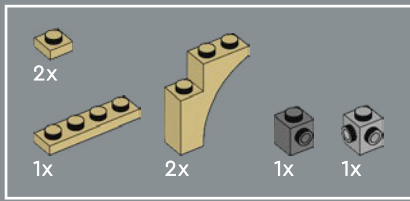

266

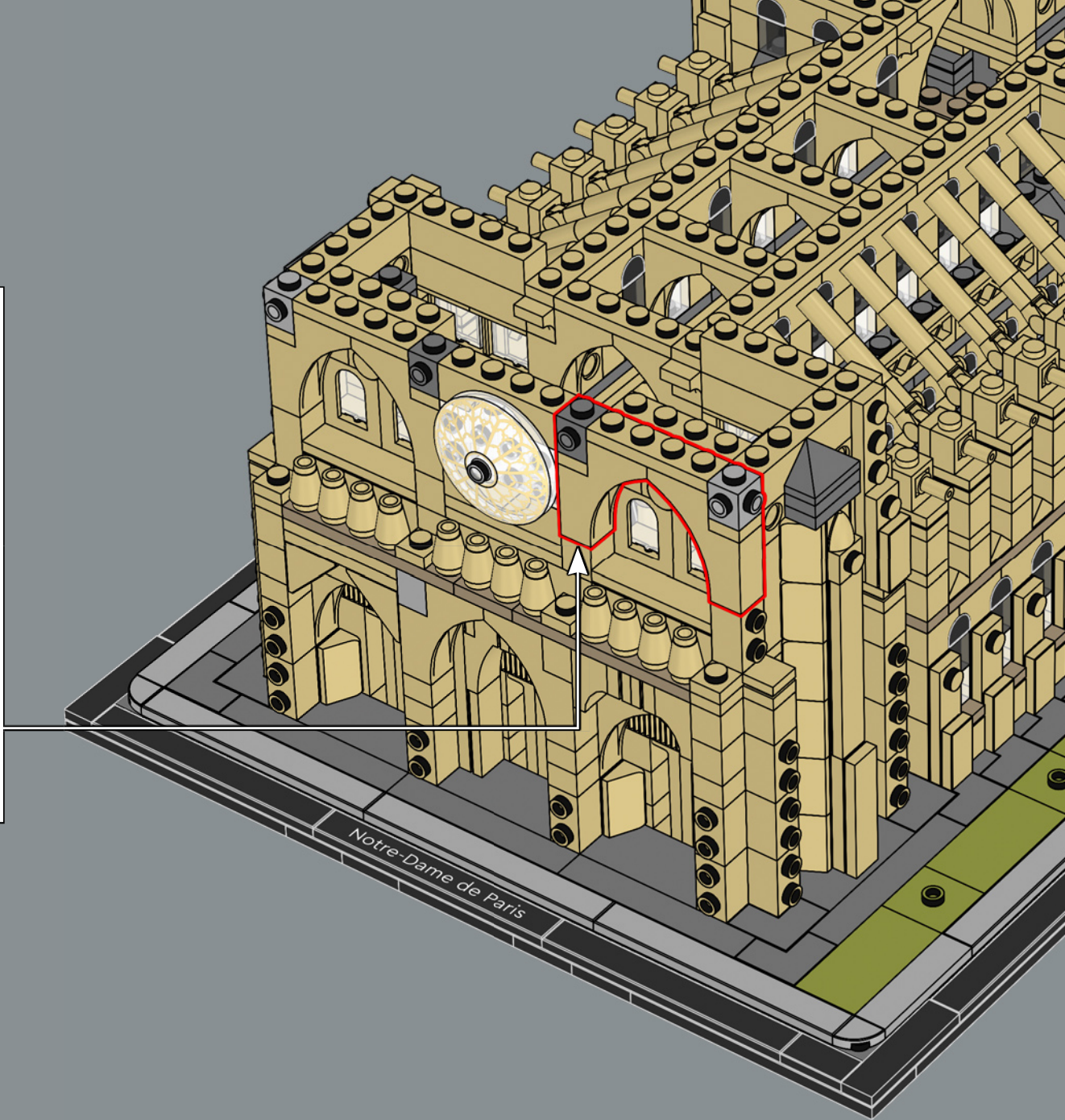
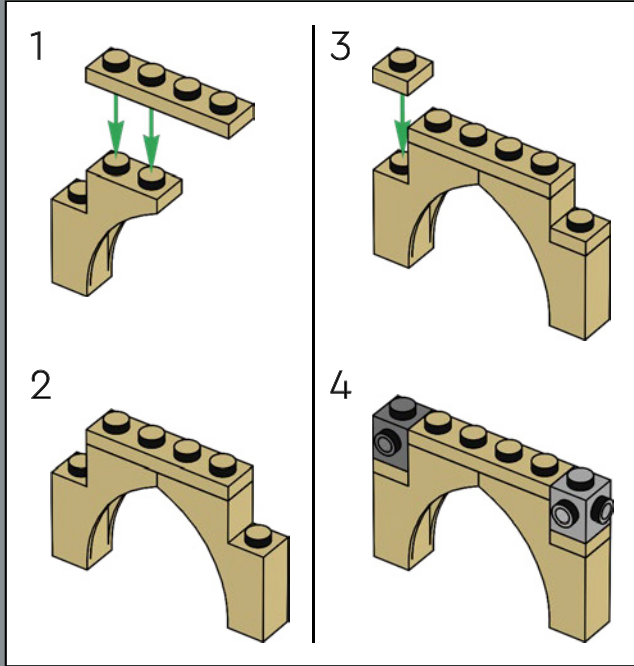



267

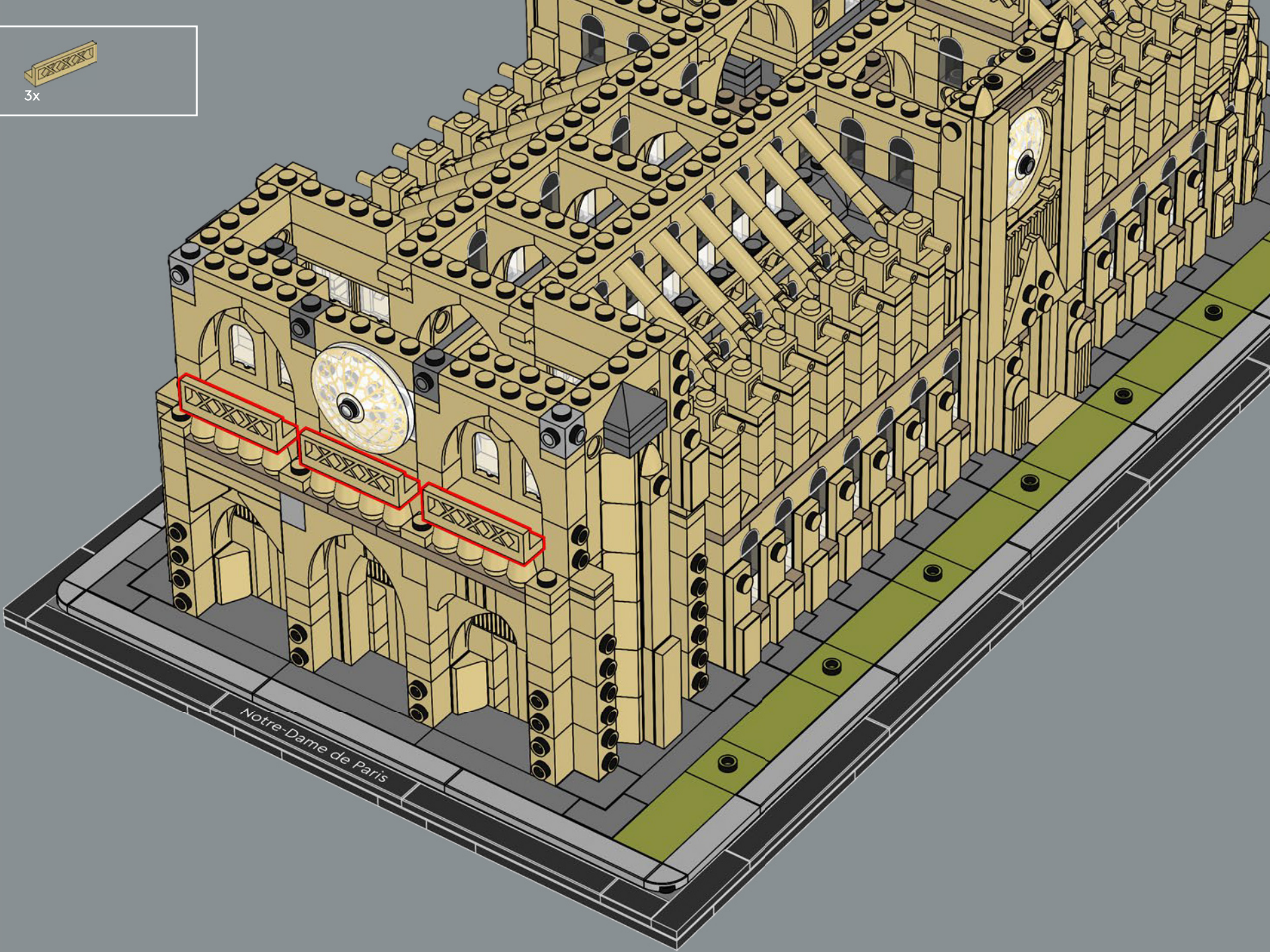

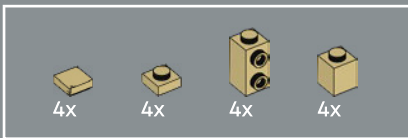

268

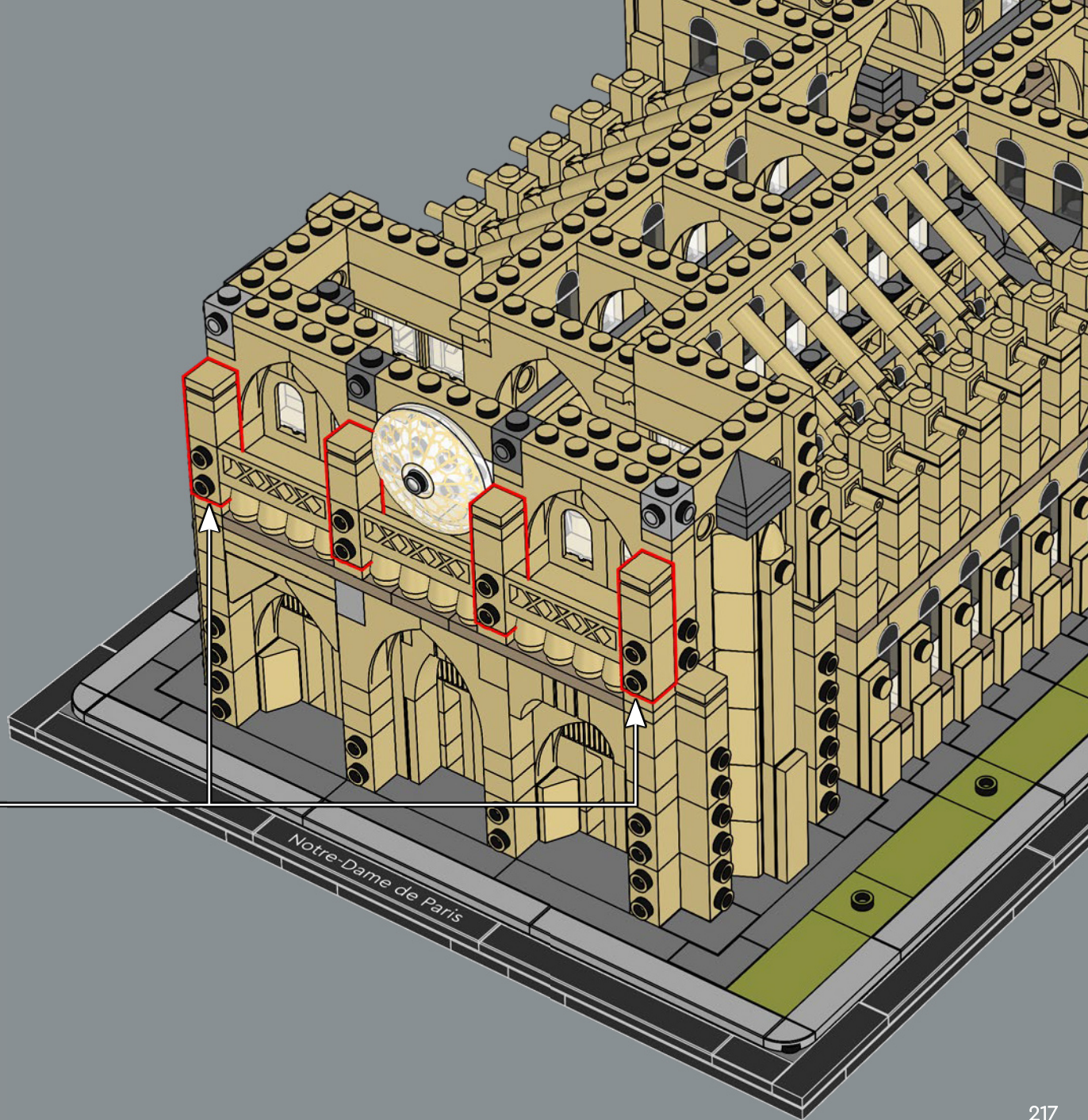
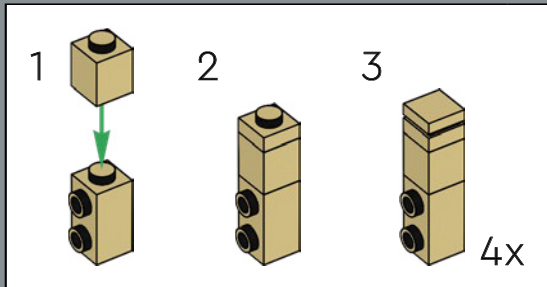

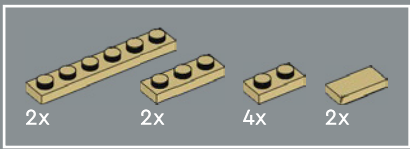

269

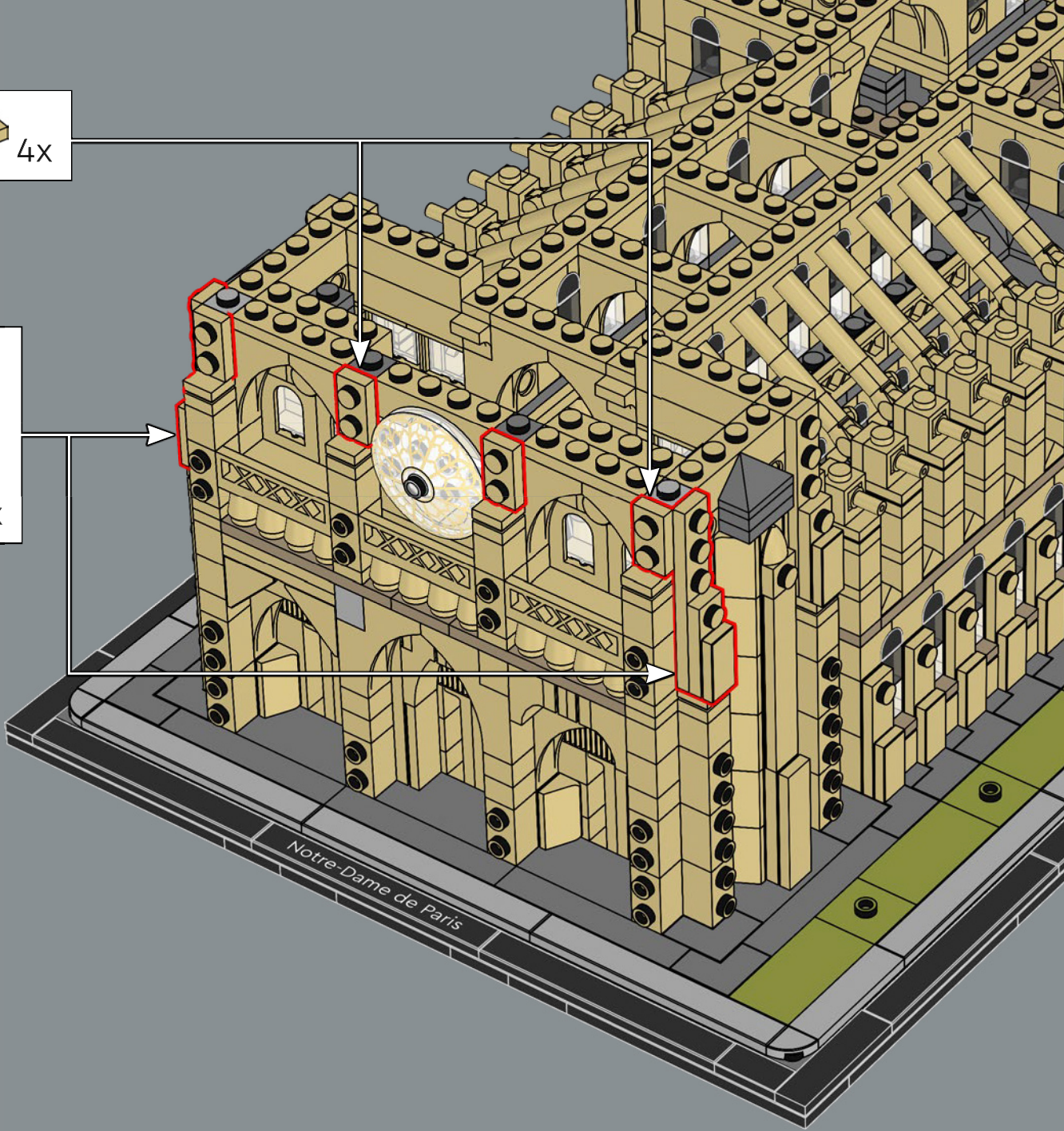
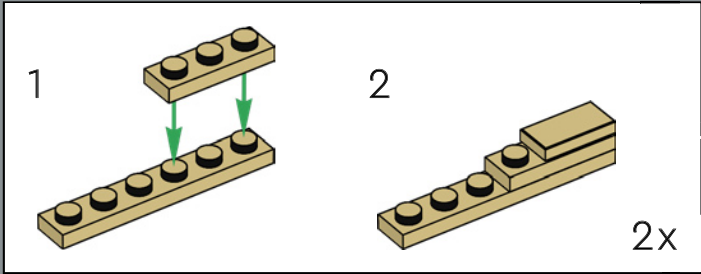
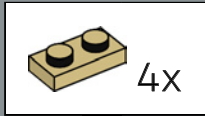

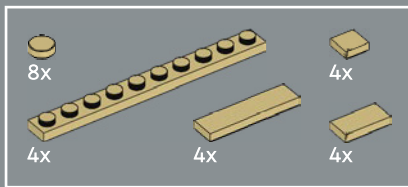

1220 – Trois portails, surmontés par la Galerie des Rois, accueillent les visiteurs et leur permettent de pénétrer dans la cathédrale par une entrée majestueuse. Les 28 statues colossales sont représentées par 20 cônes et éléments ronds LEGO®.

270

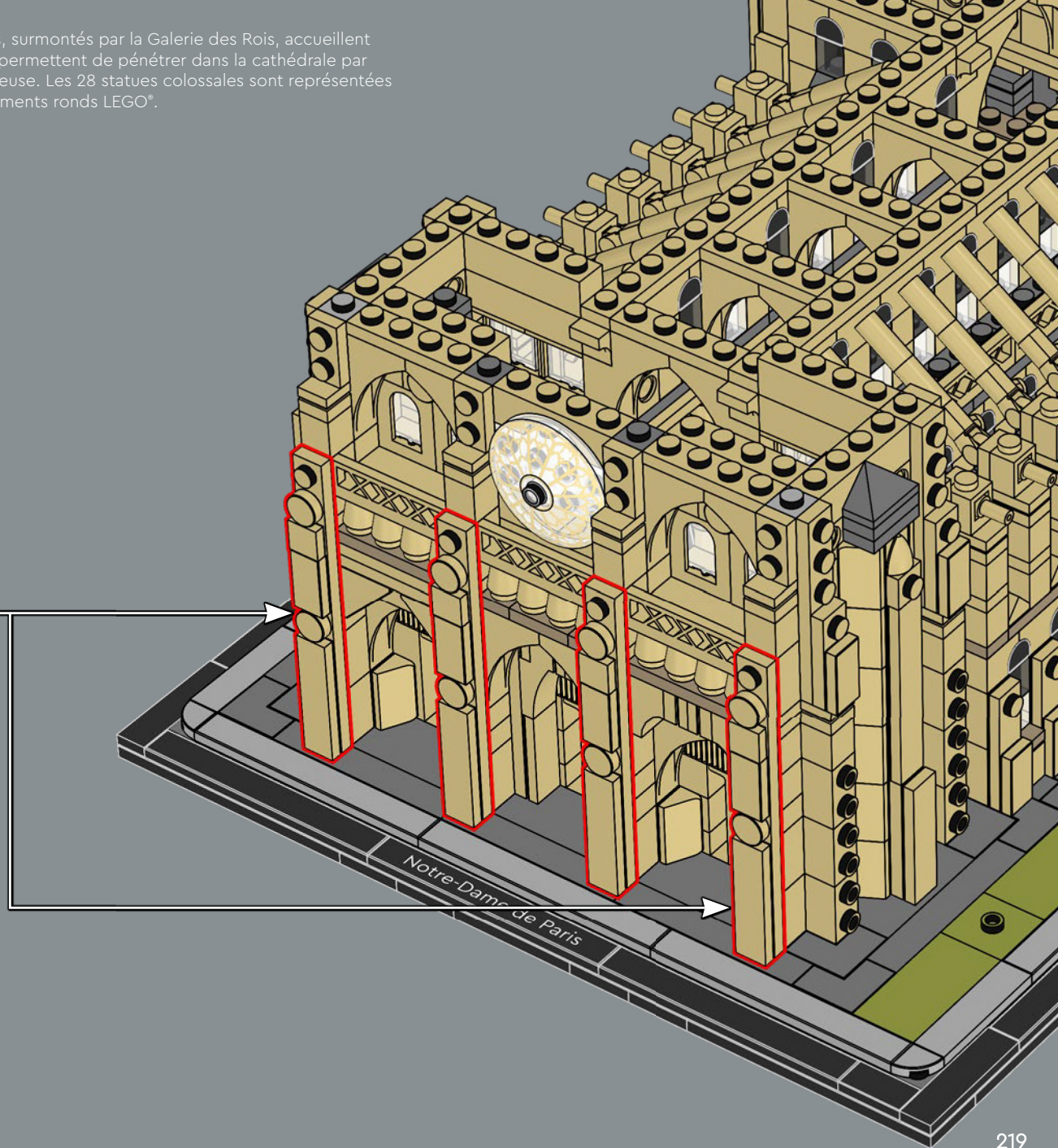
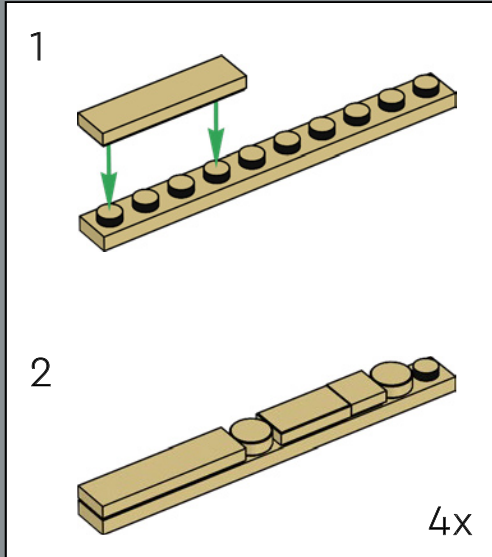

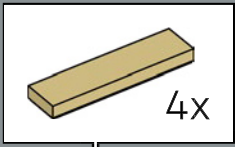
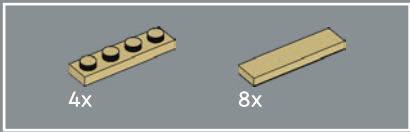

271

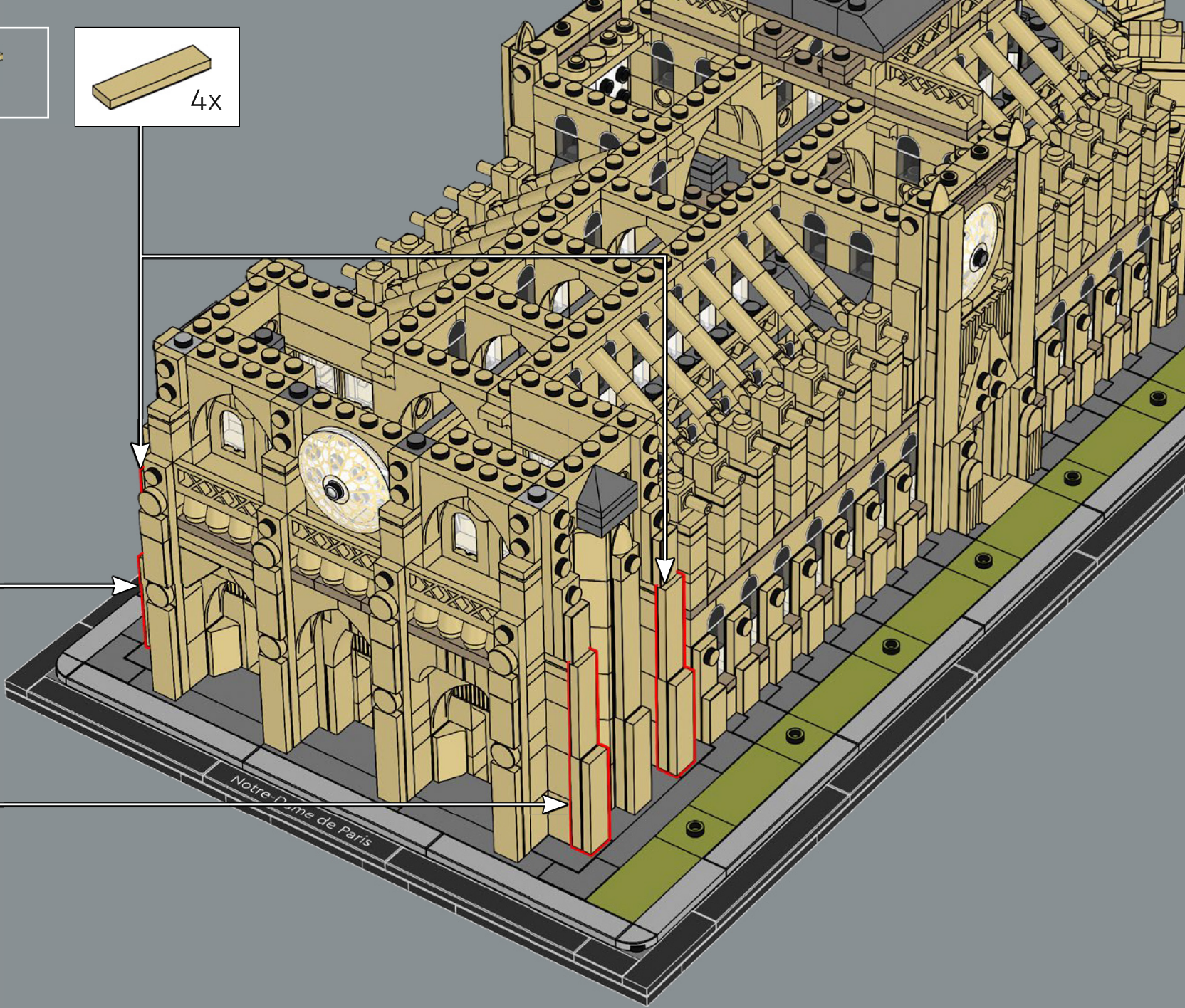
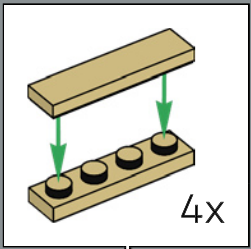

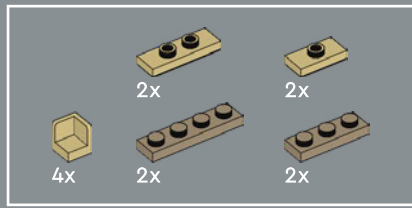

272

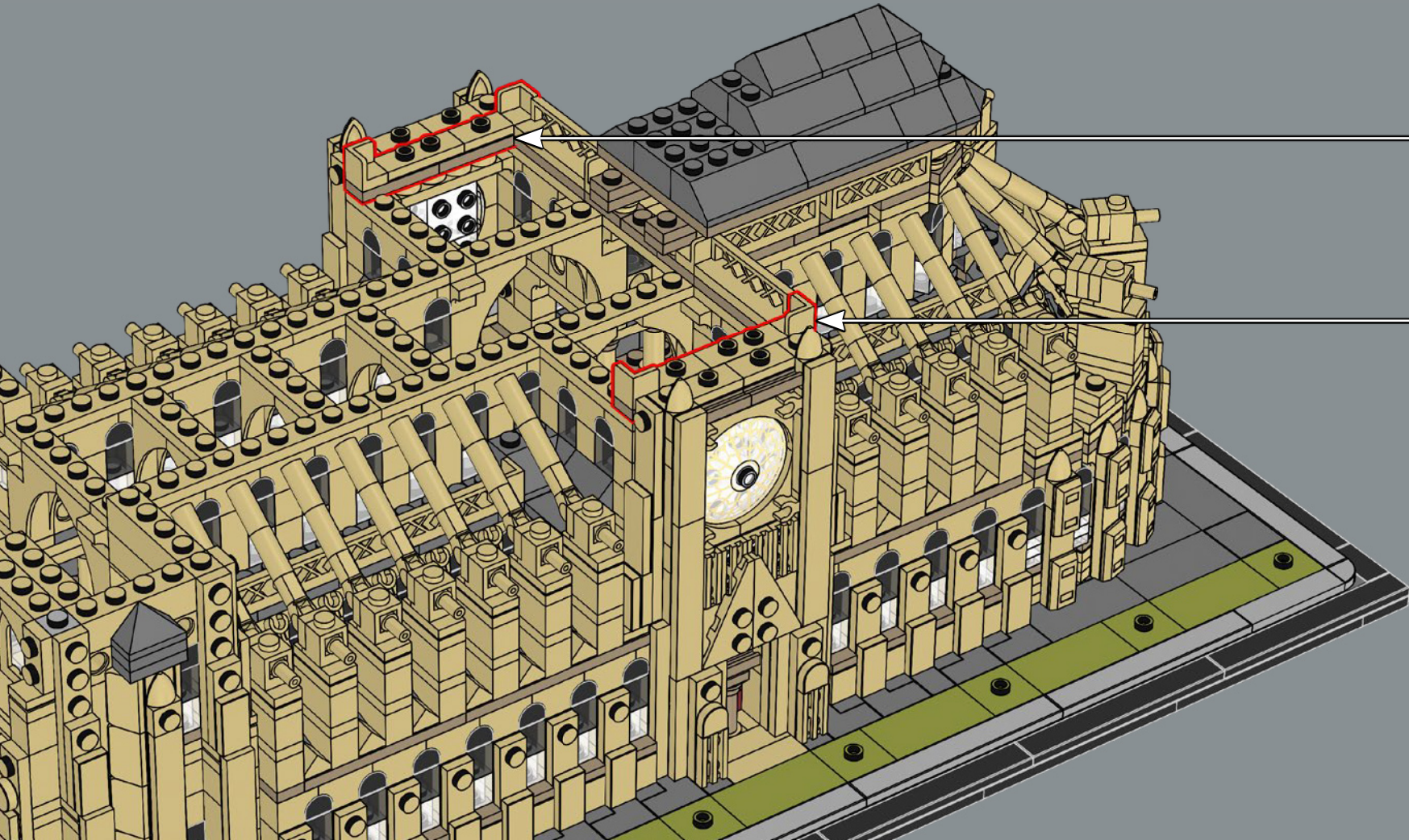
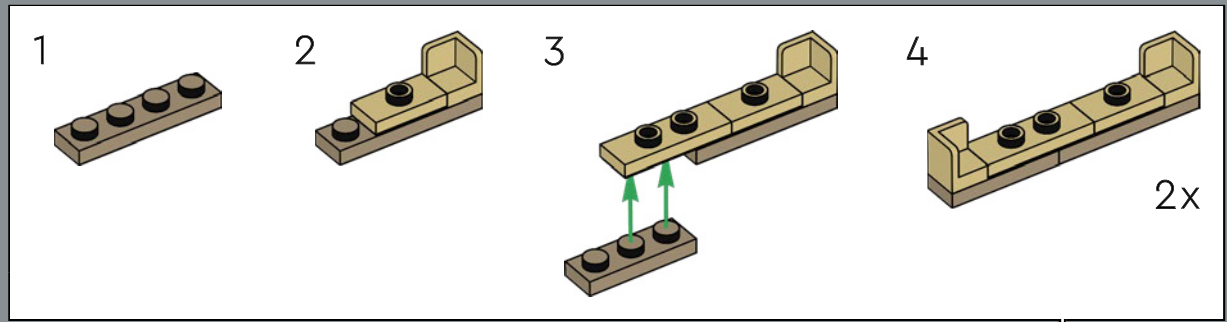

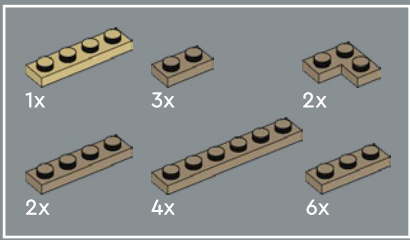

273

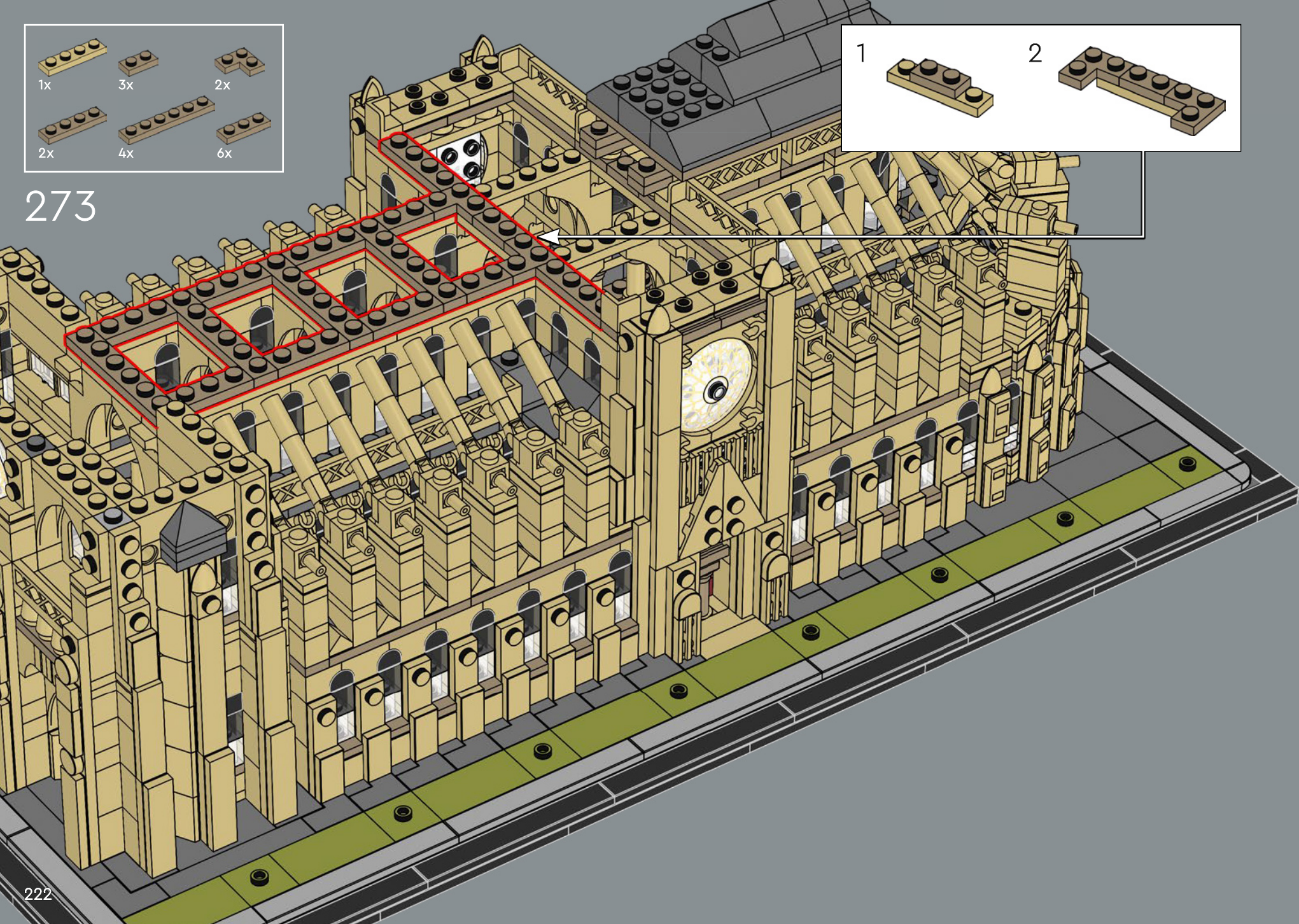
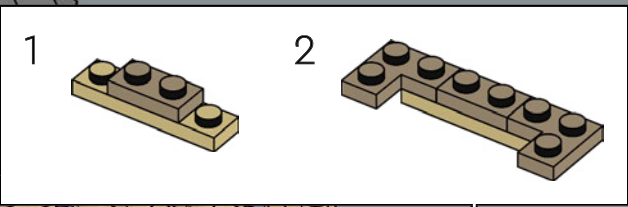

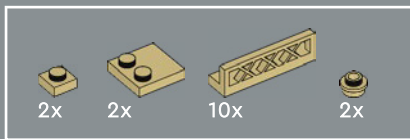

274

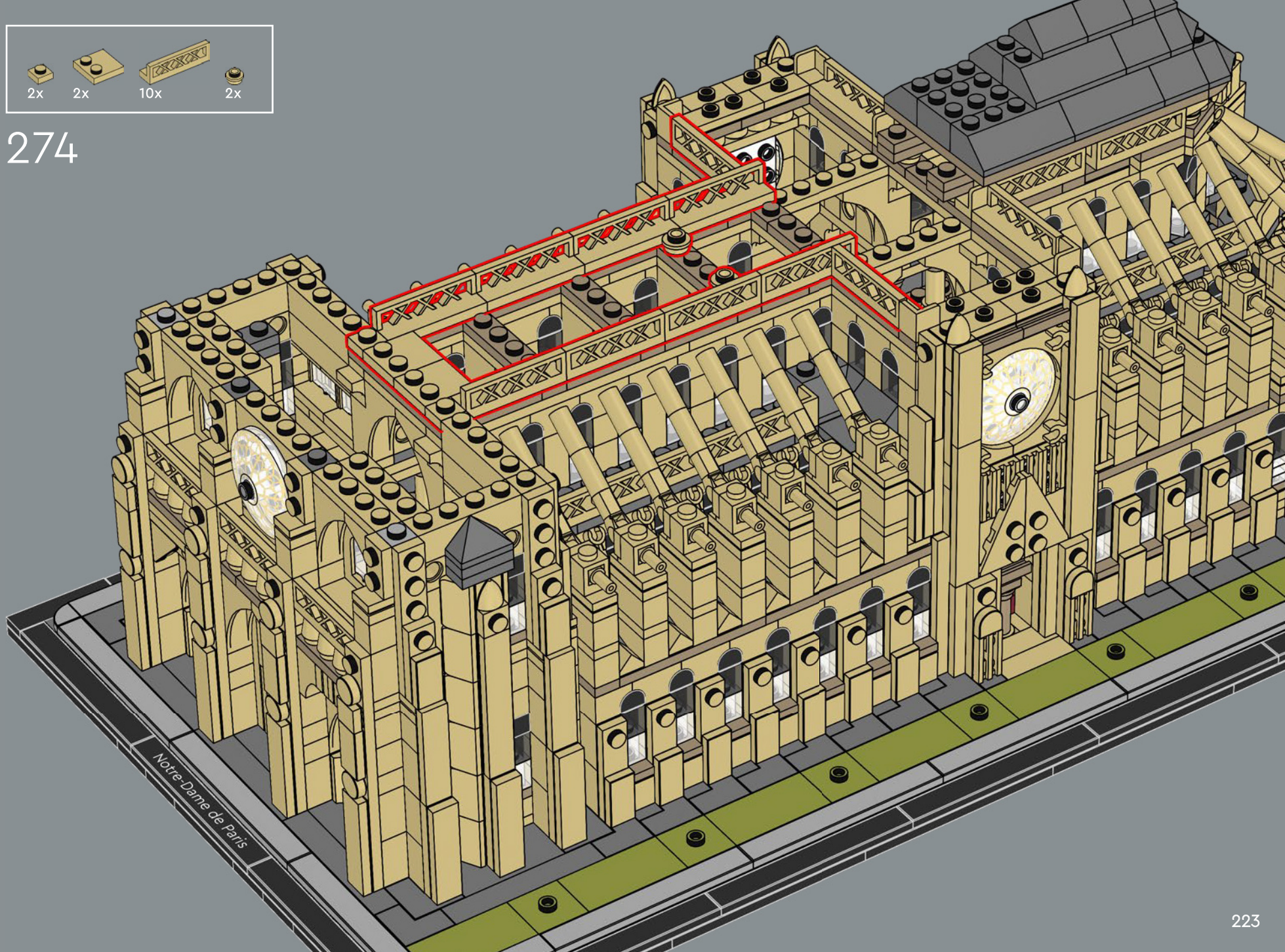



LA TRANSFORMATION SE POURSUIT

✂ En 1245, toutes les tours sont achevées. Au fil de la construction des tours, vous découvrirez quelques éléments du mécanisme interne du beffroi de la cathédrale ainsi que la superstructure qui supporte les cloches légendaires. Au cours des cinq siècles suivants, l'usure fait son œuvre. De nouvelles générations d'architectes supervisent les modifications, les réparations et les ajouts, tels que la construction d'une flèche en bois recouverte de plomb au-dessus de la croisée du transept. En 1300, les chapelles sont ajoutées autour du chœur.



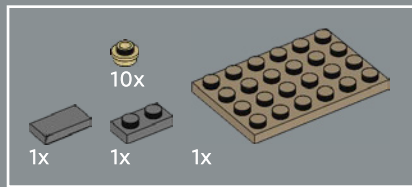

275

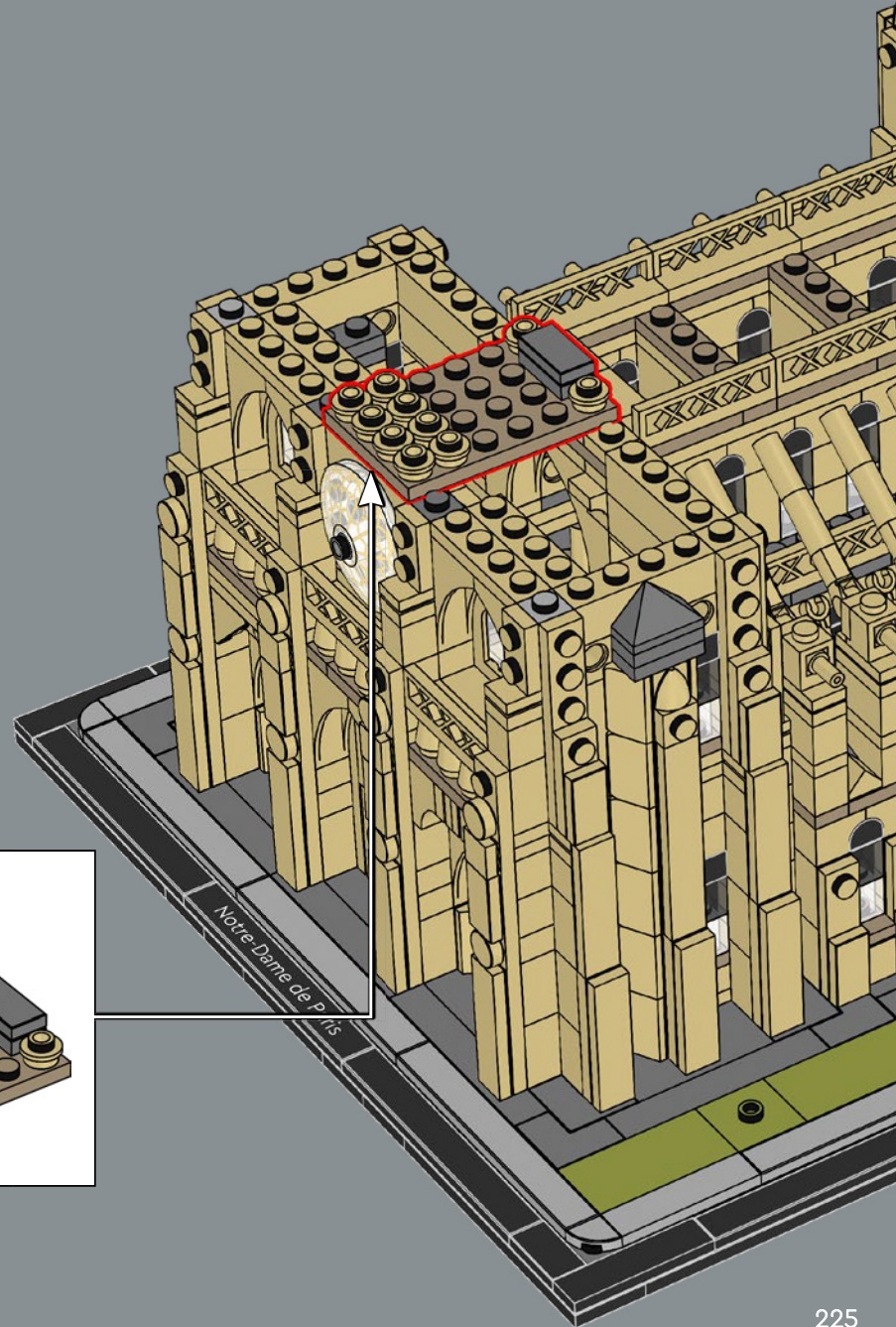
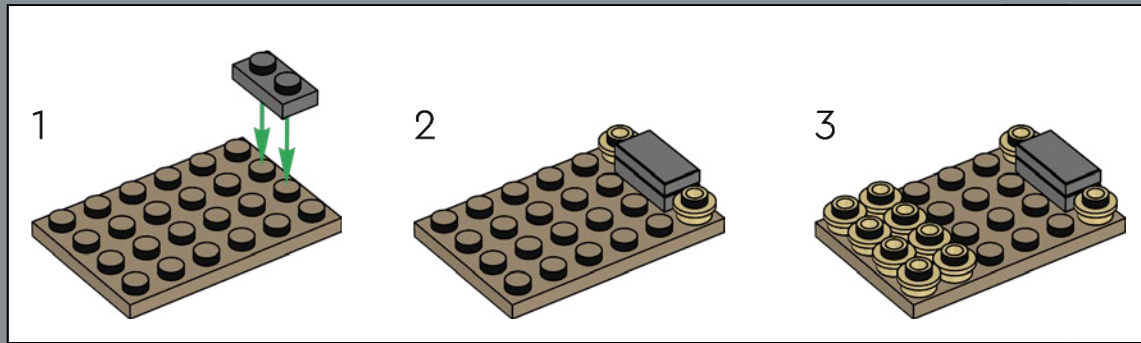

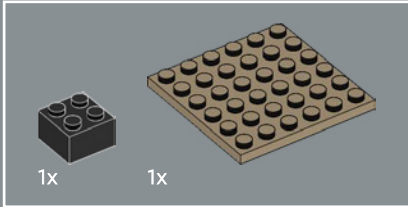
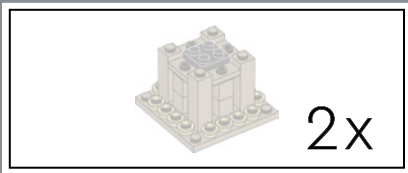

276

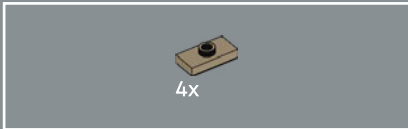
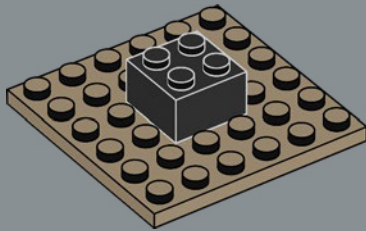

277

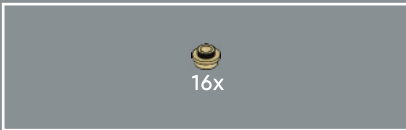
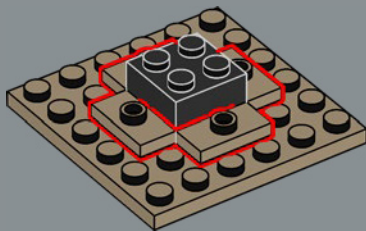

278

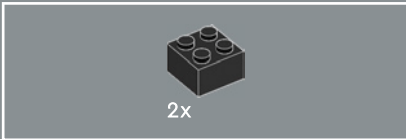
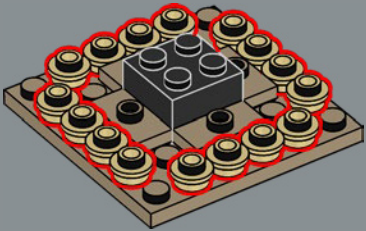

279

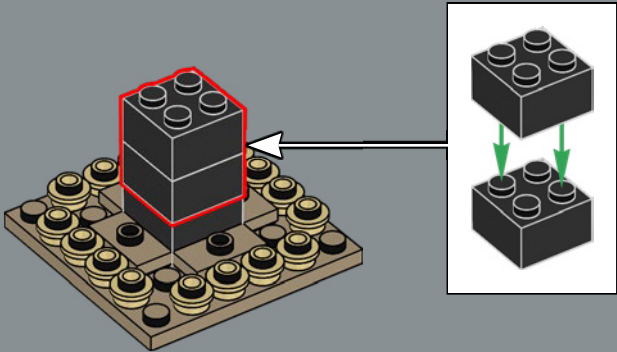



280

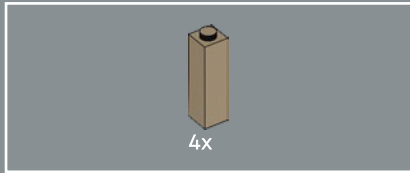
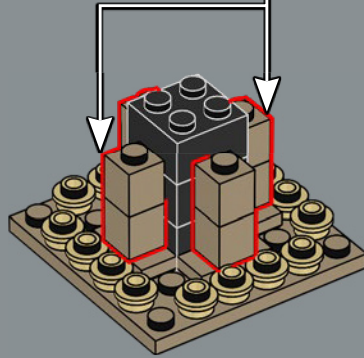
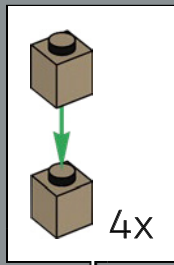

281

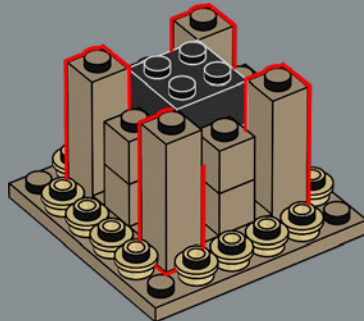

282

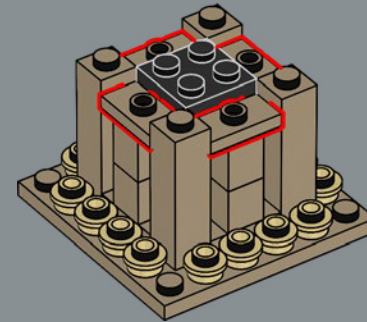

2x

283



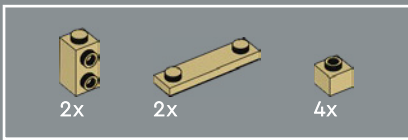

284

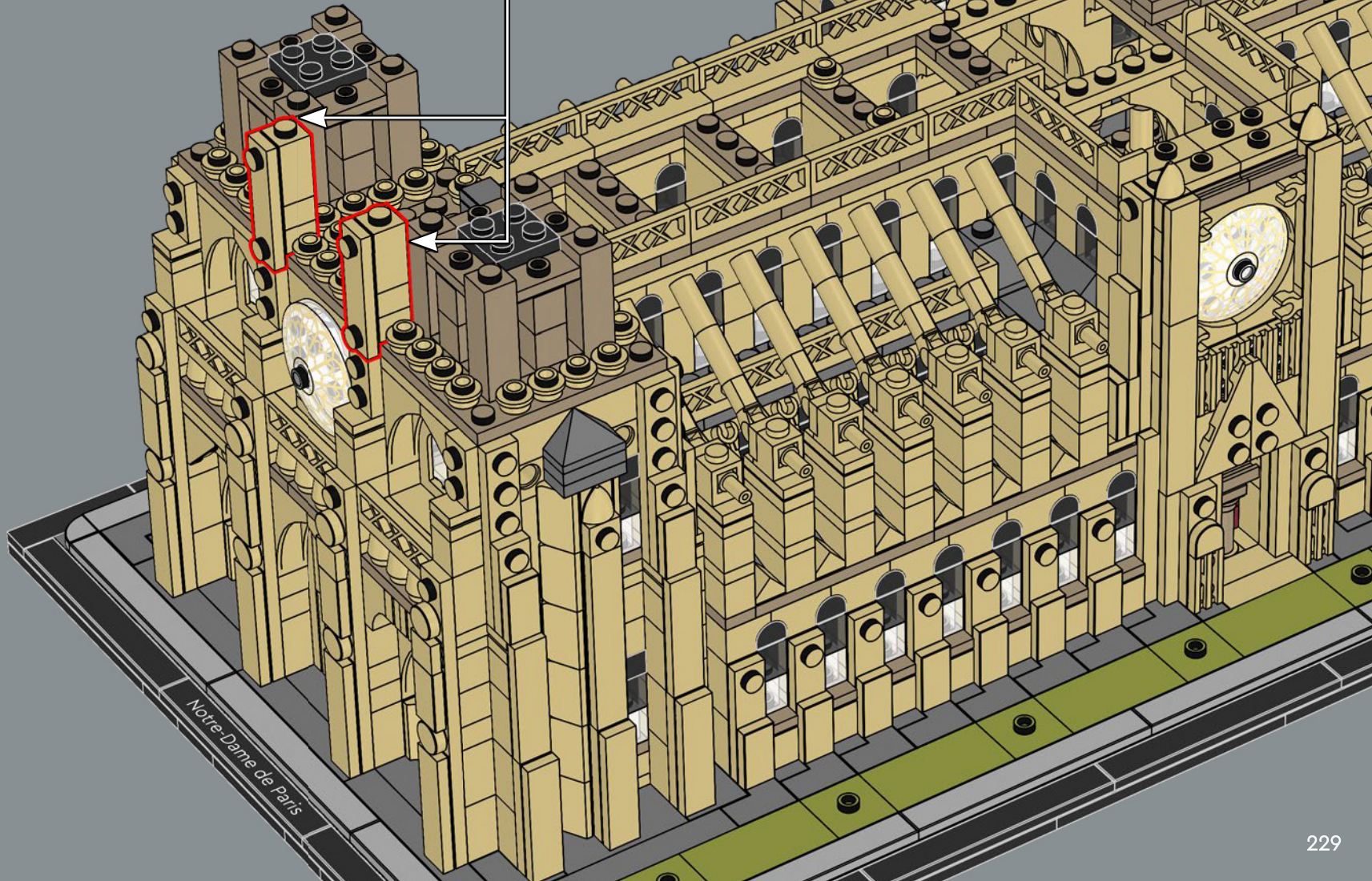
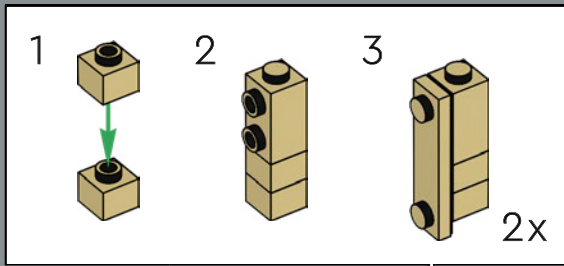



285

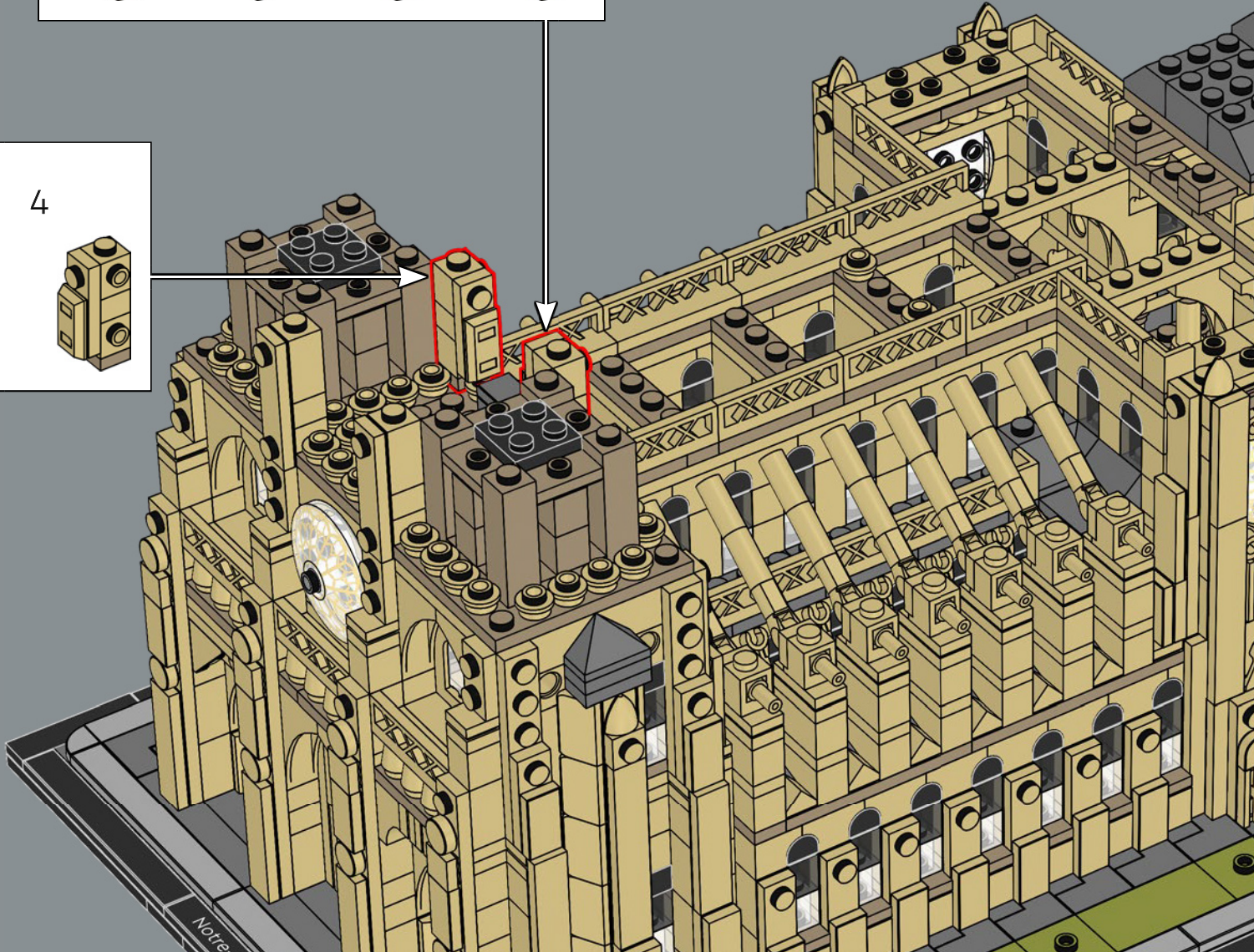
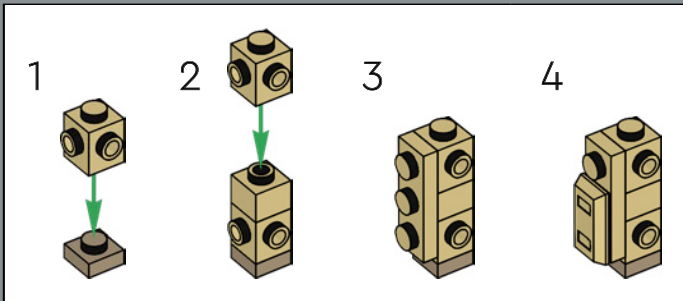
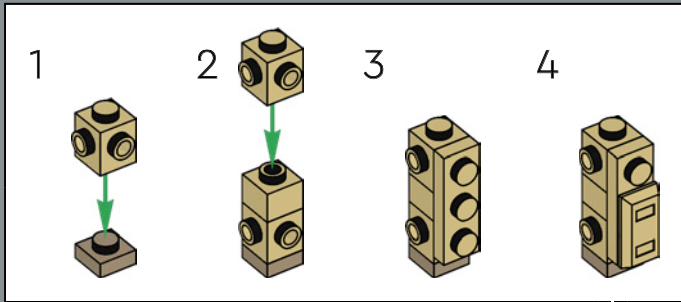

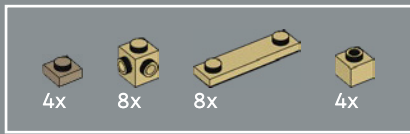

286

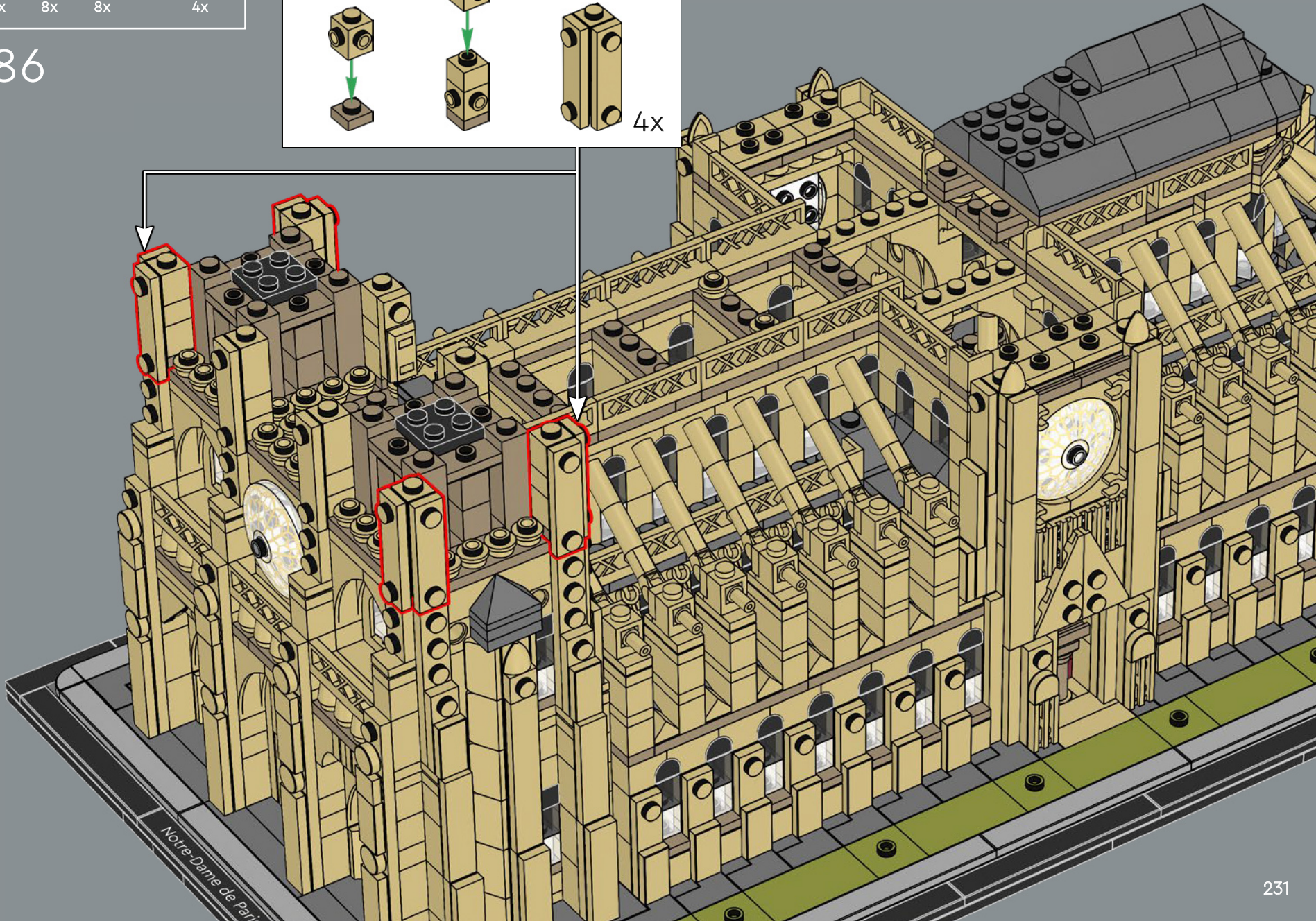
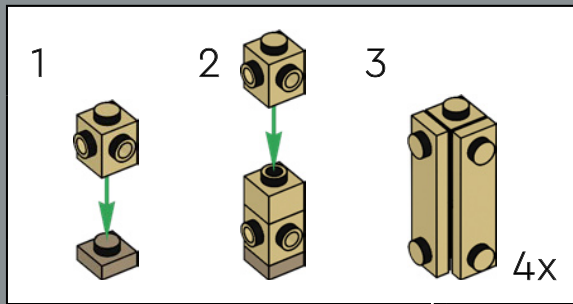

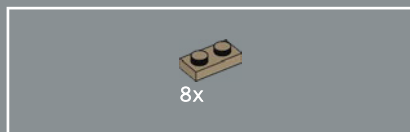

287

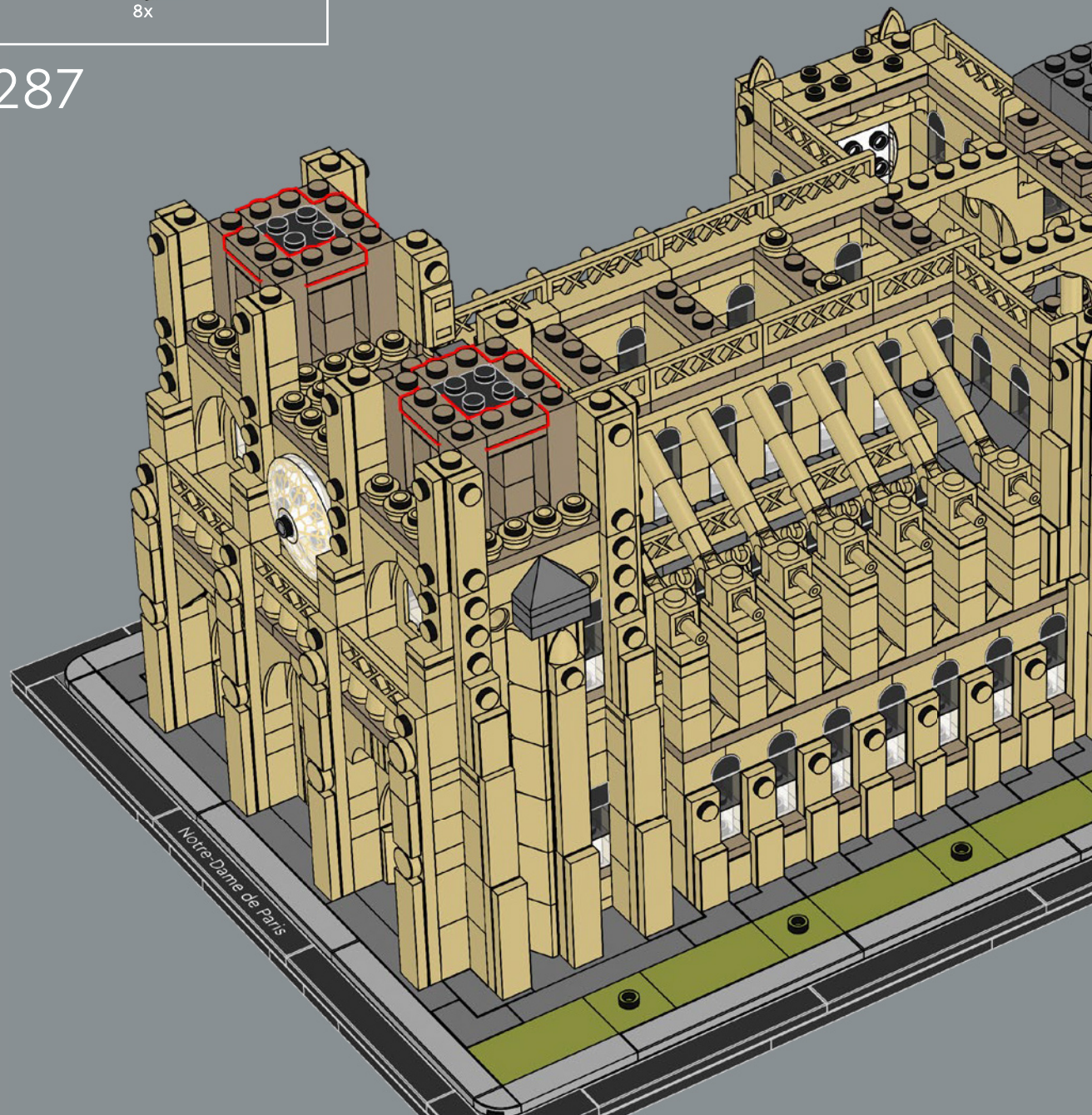



40x

288

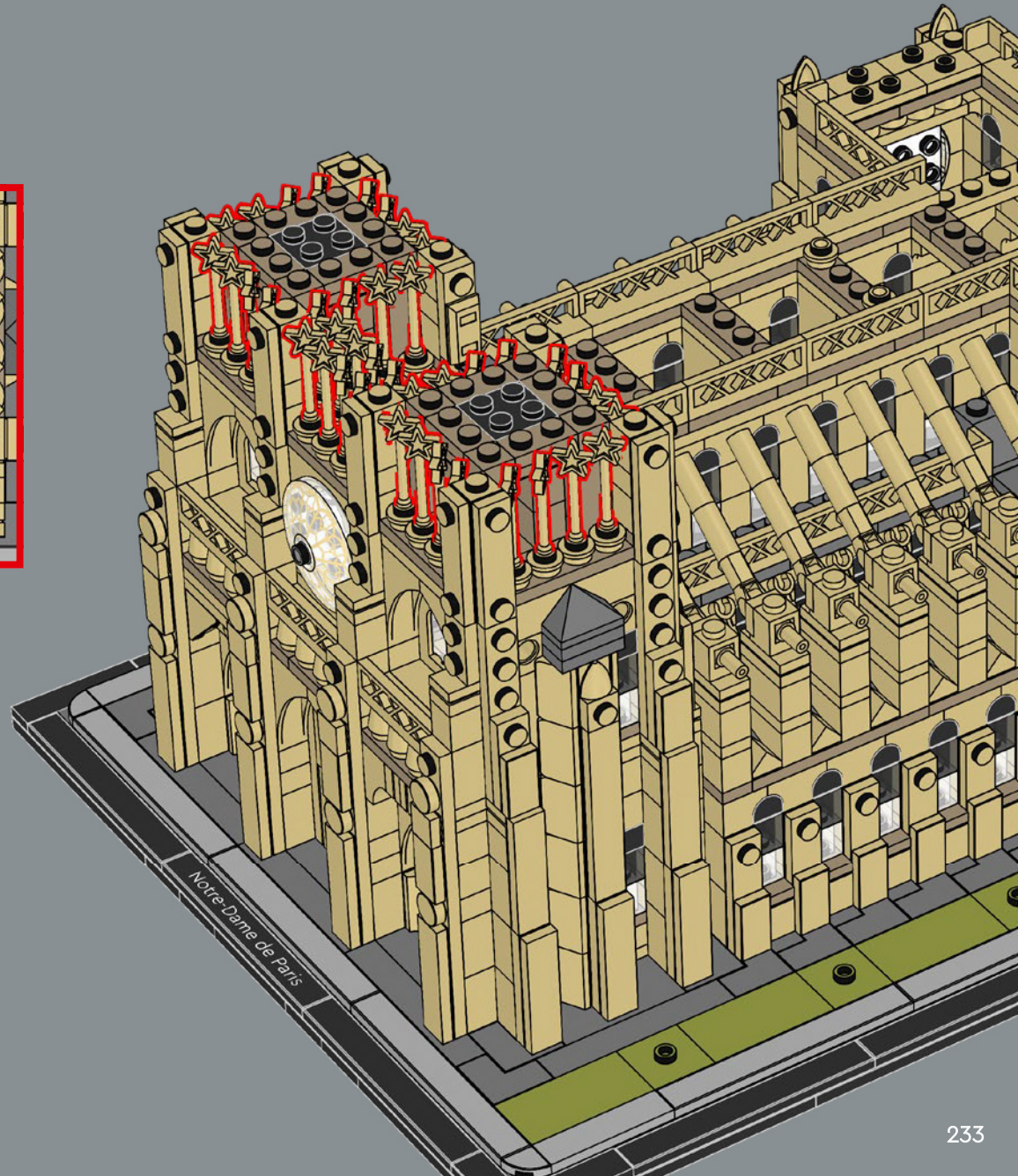
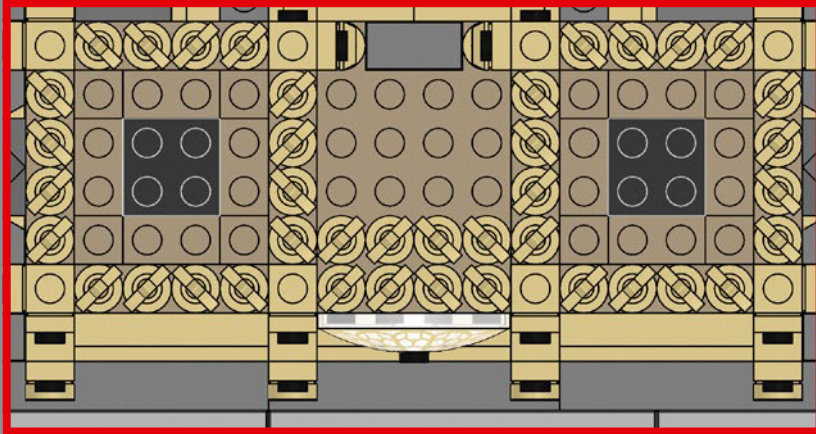

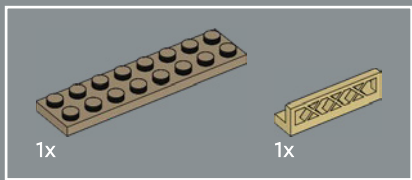

289

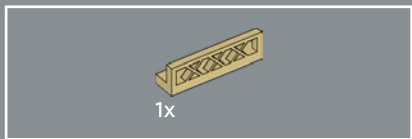
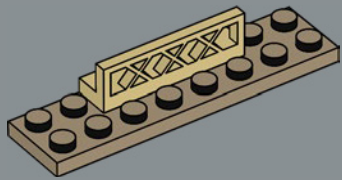

290

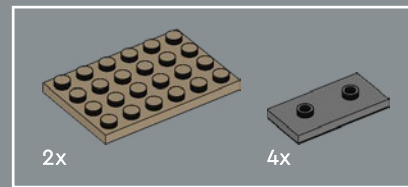
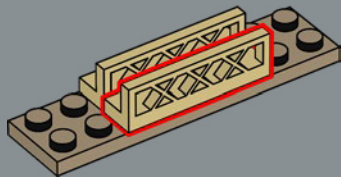

291

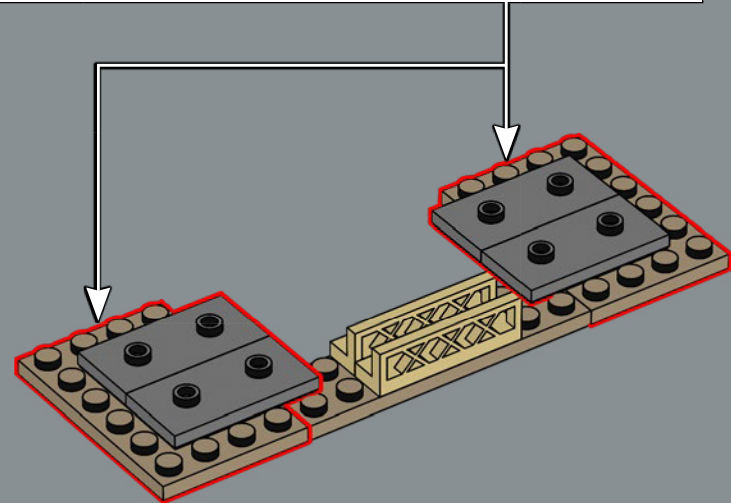
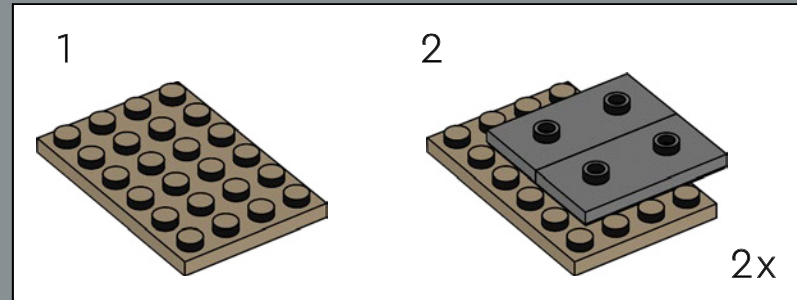

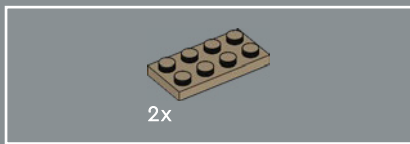

292

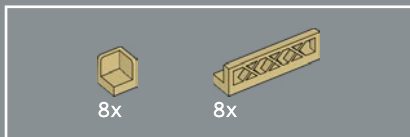
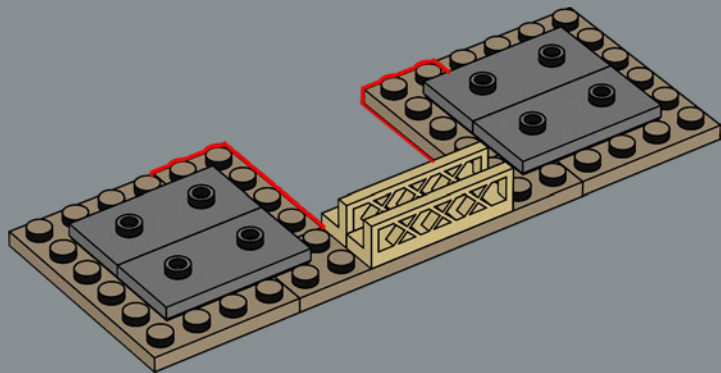

293

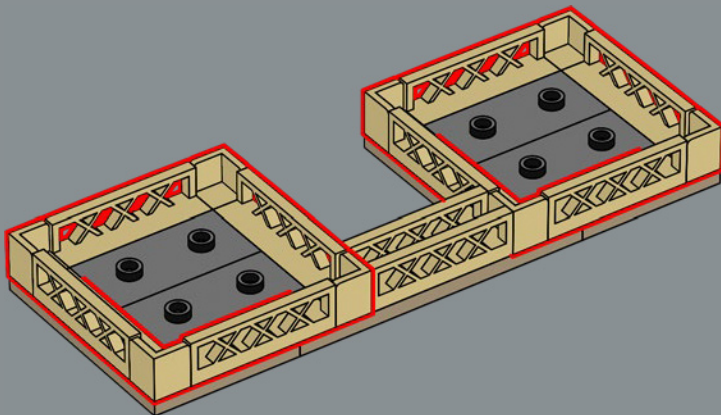

294

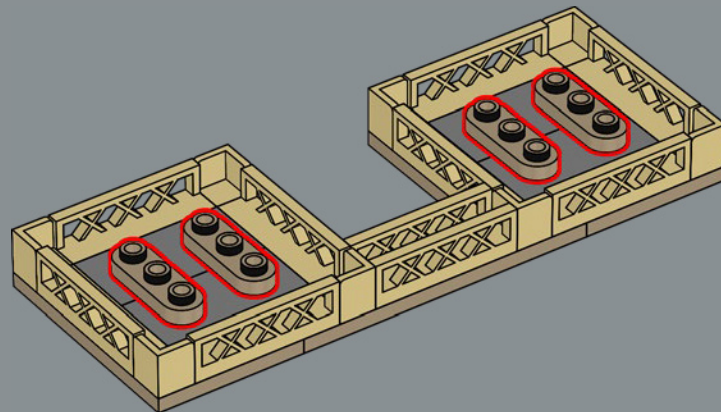

295

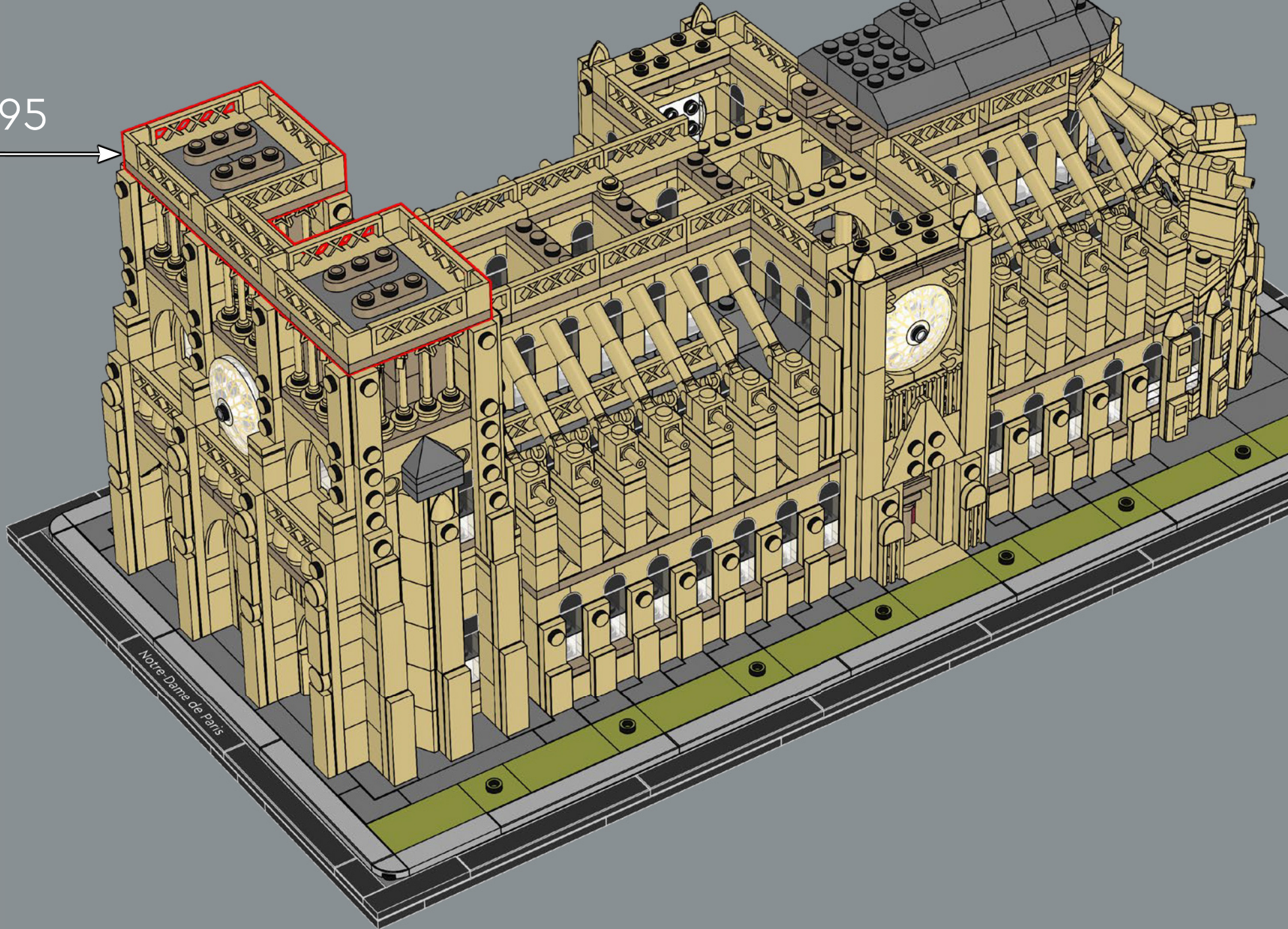

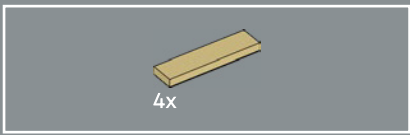

296

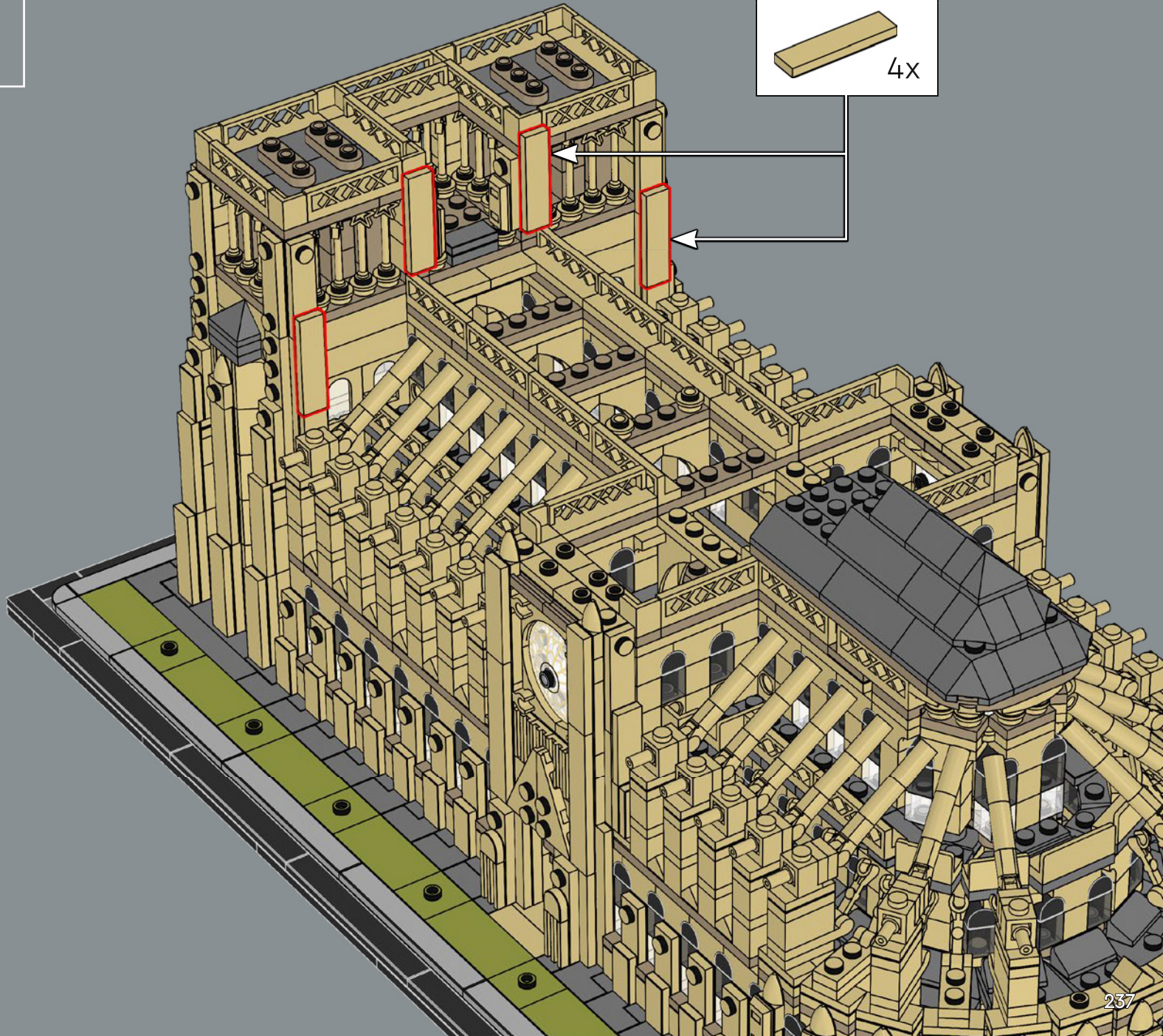
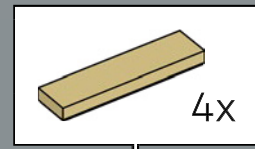



297

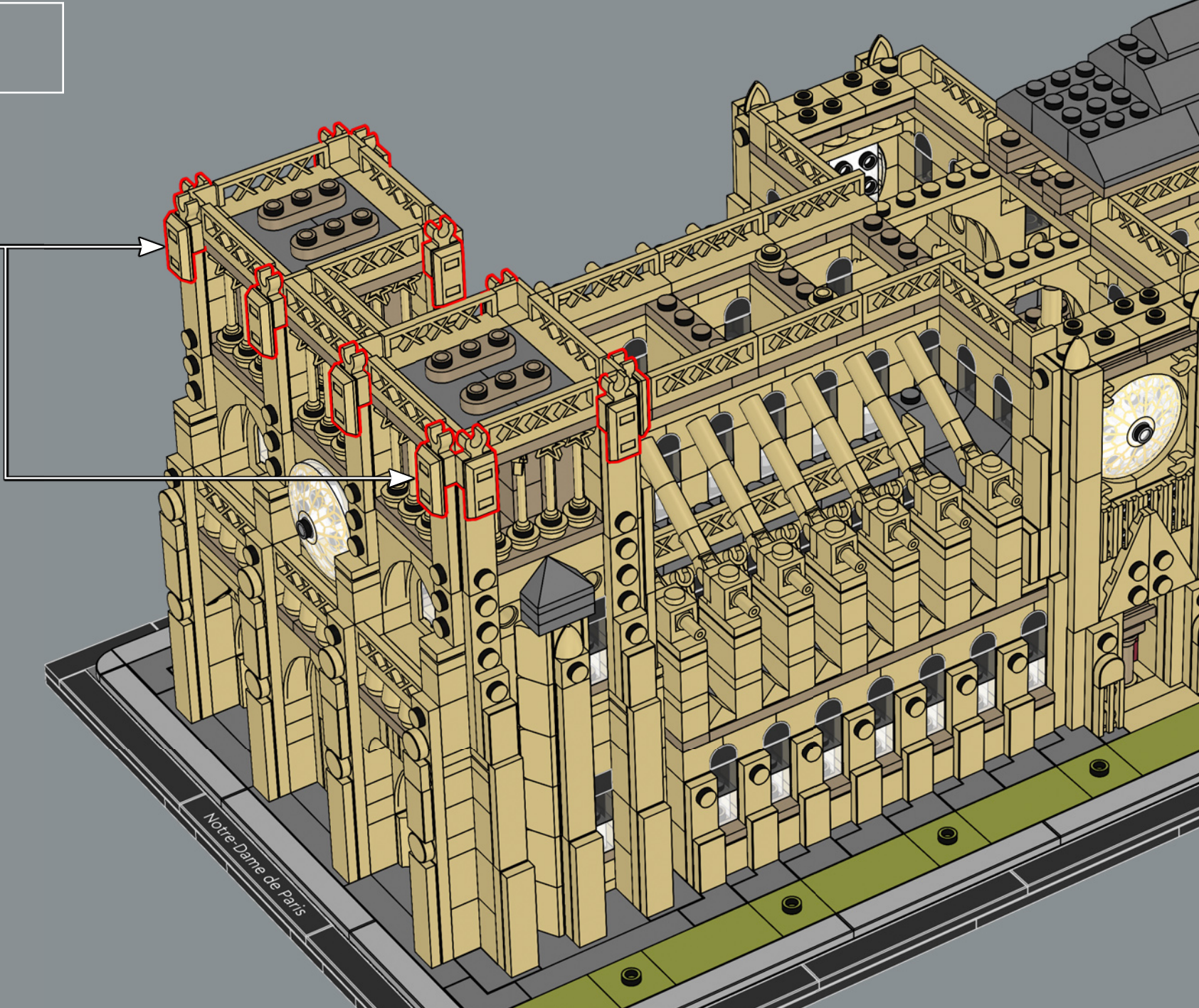
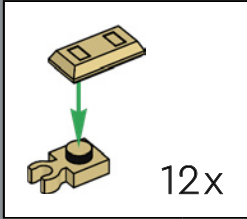

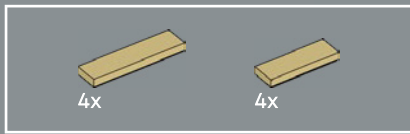

298

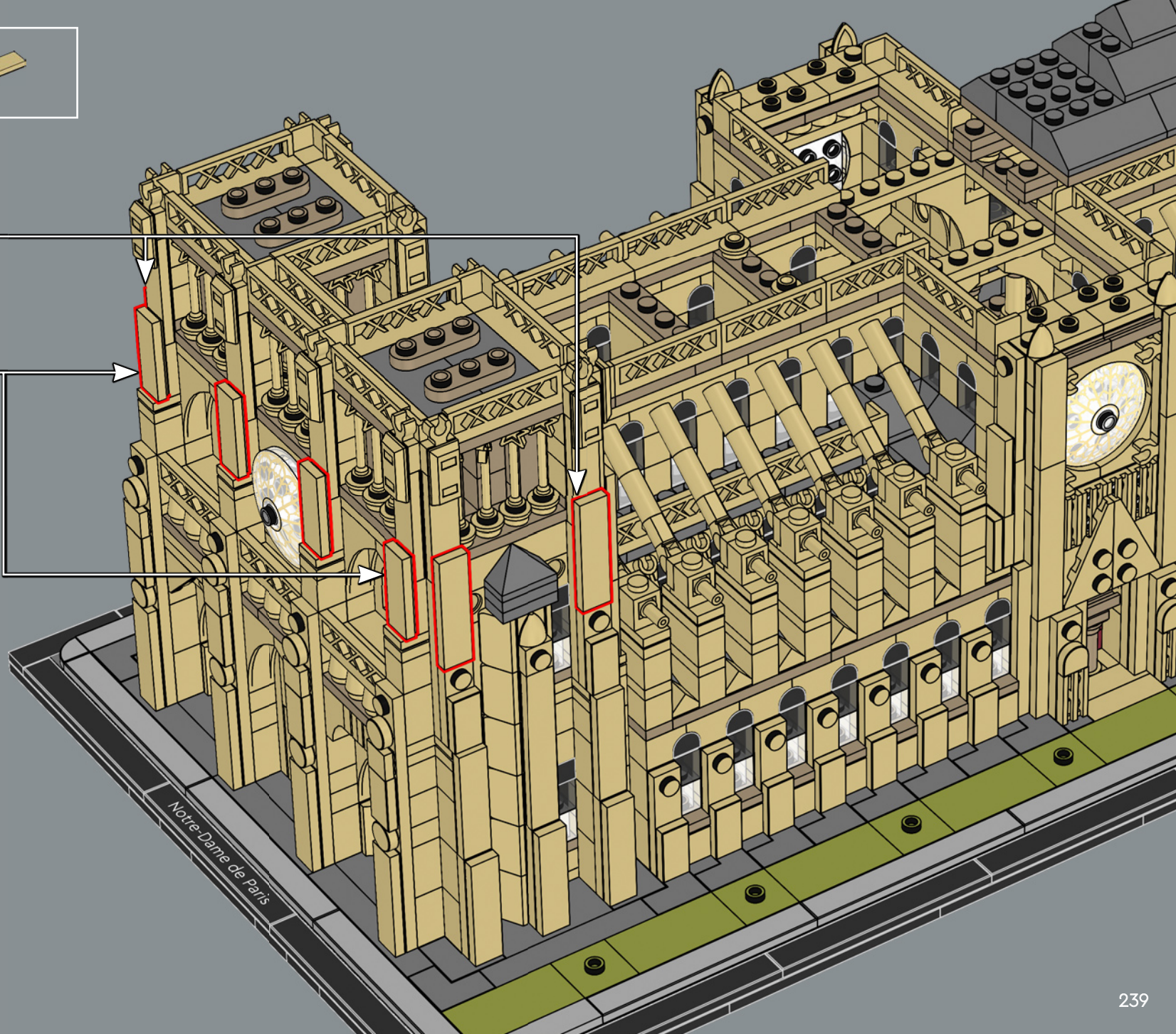
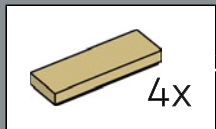
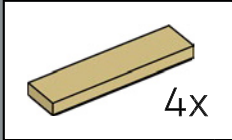



4x

299



4x

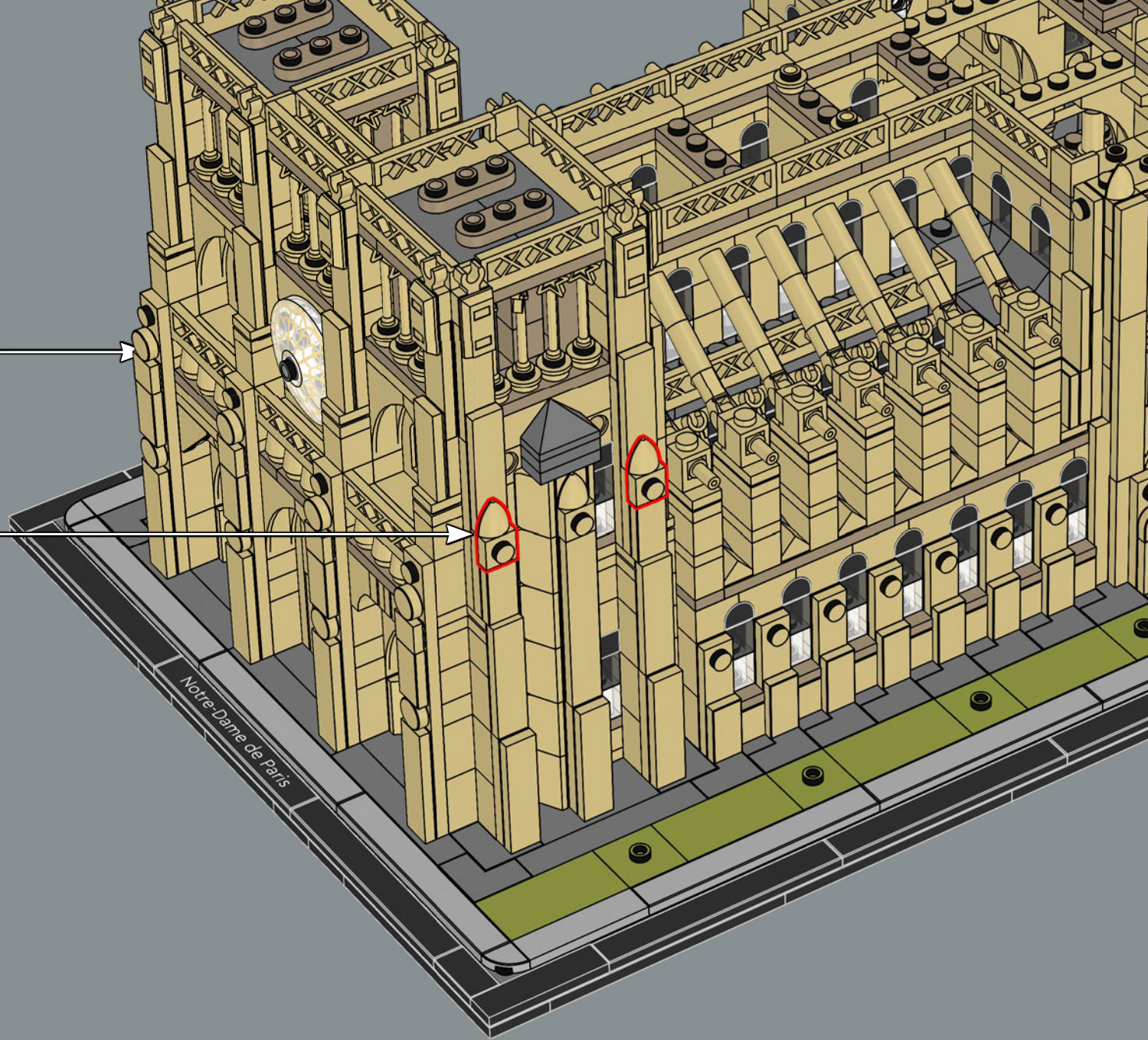

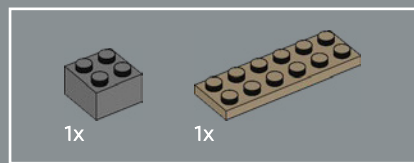
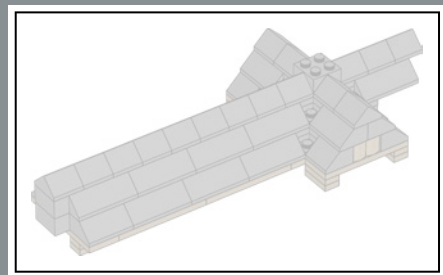

300

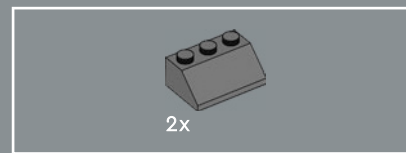
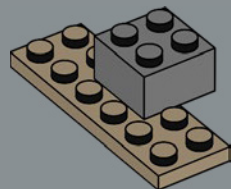

301

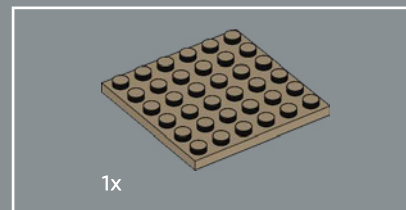
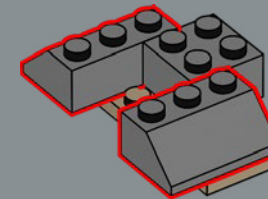

302

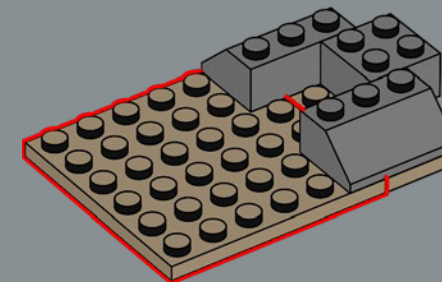

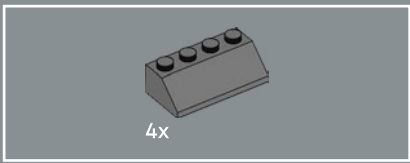

303

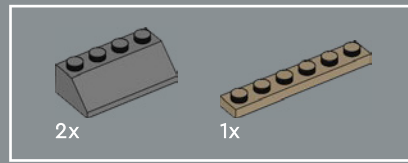
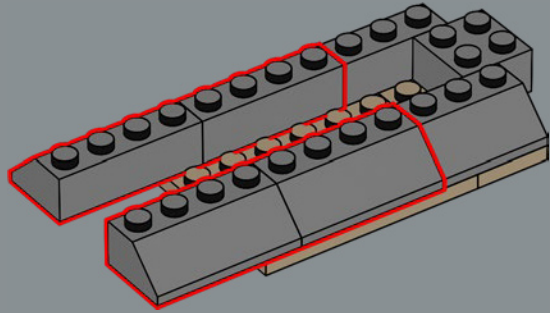

305

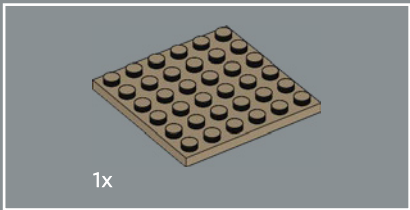
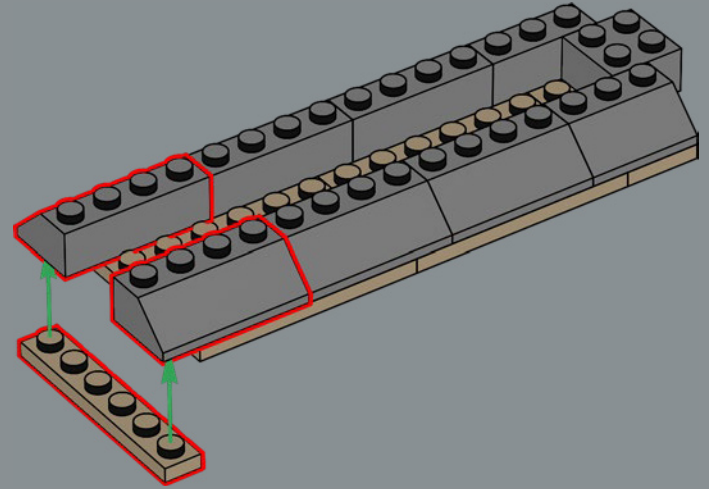

304

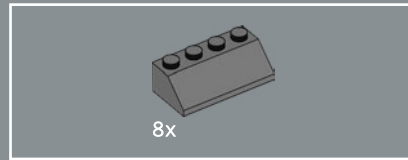
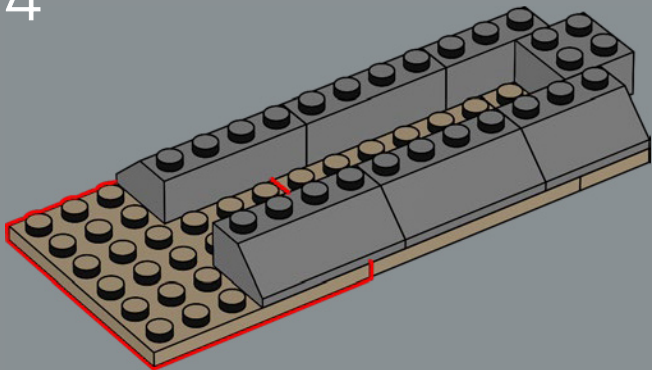

306

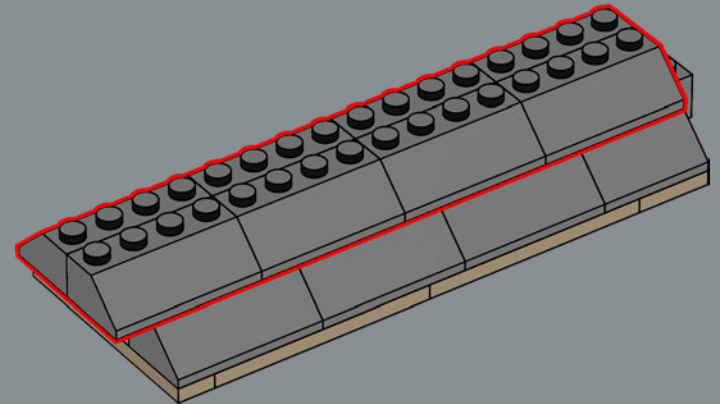

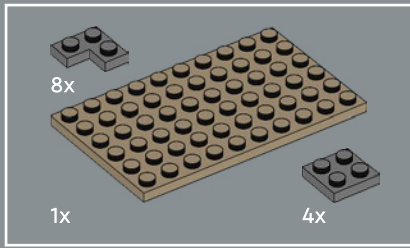

307

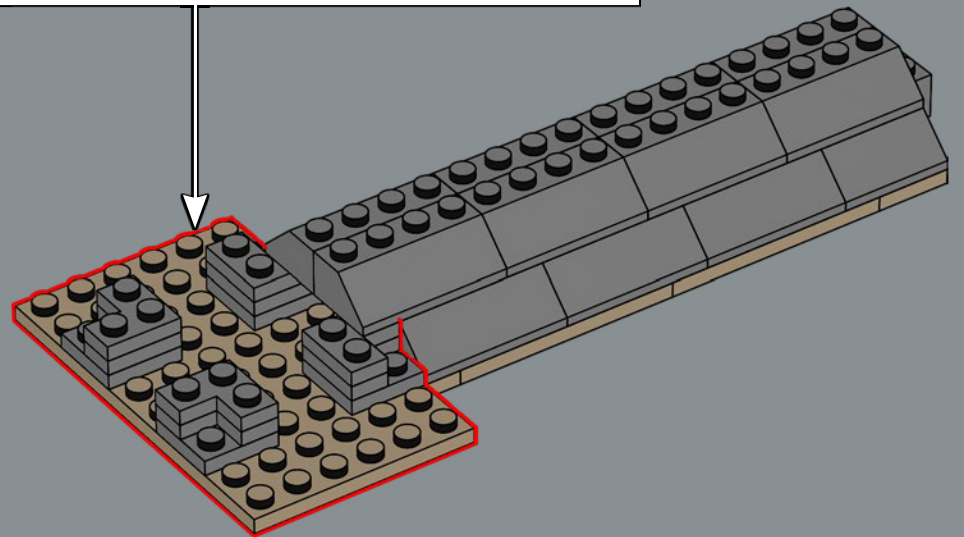
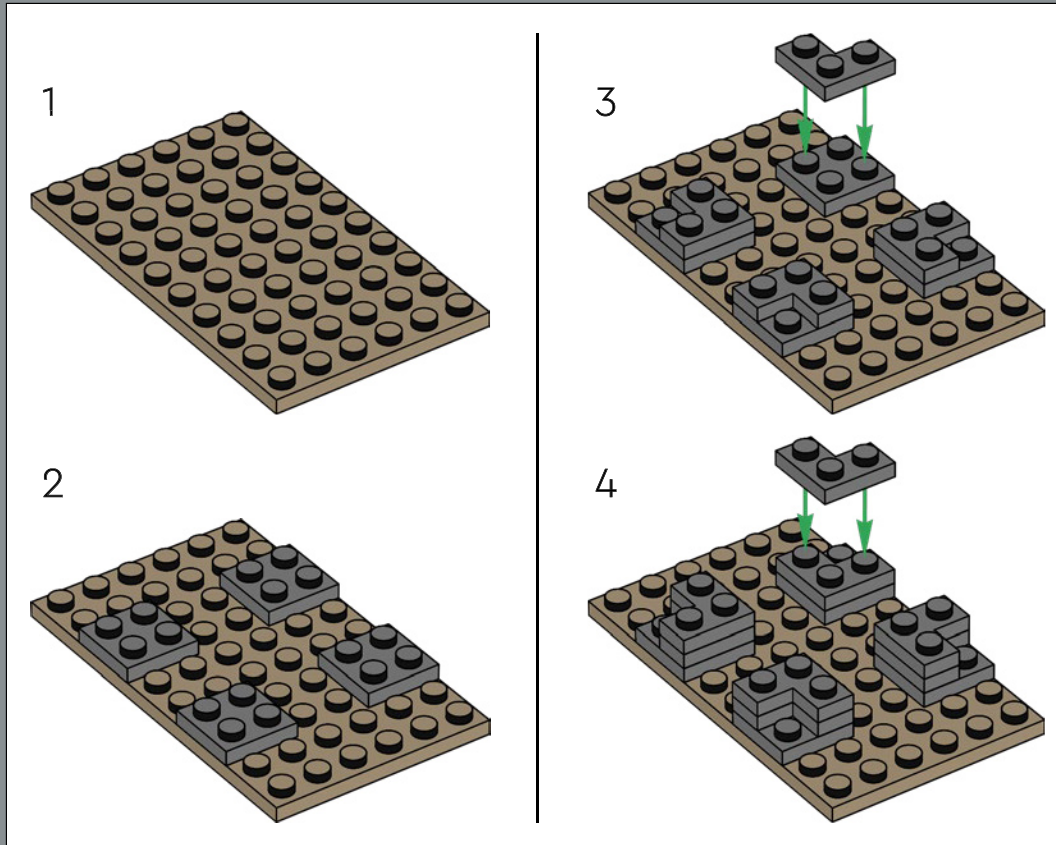

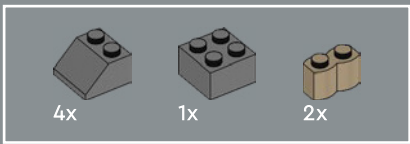

308

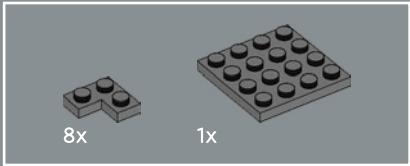
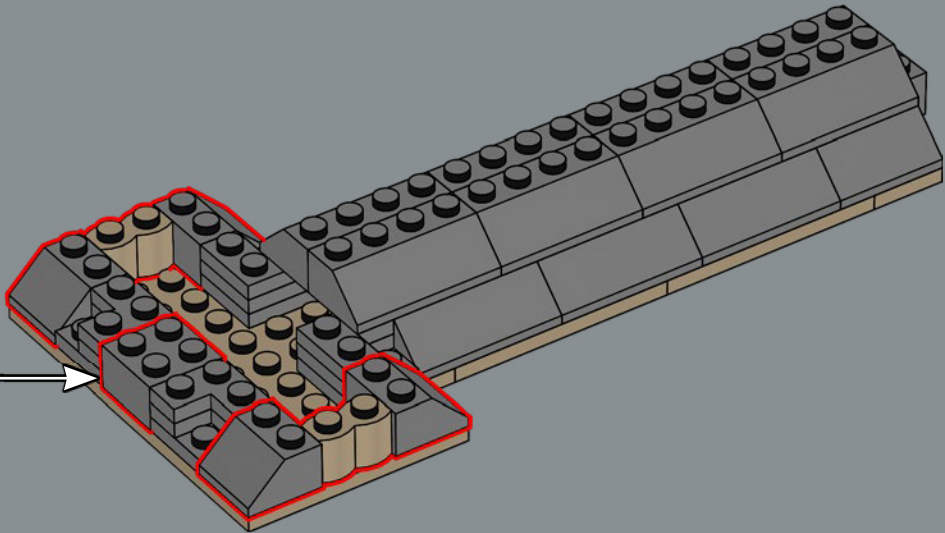
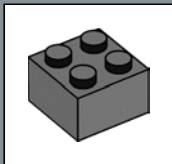

309

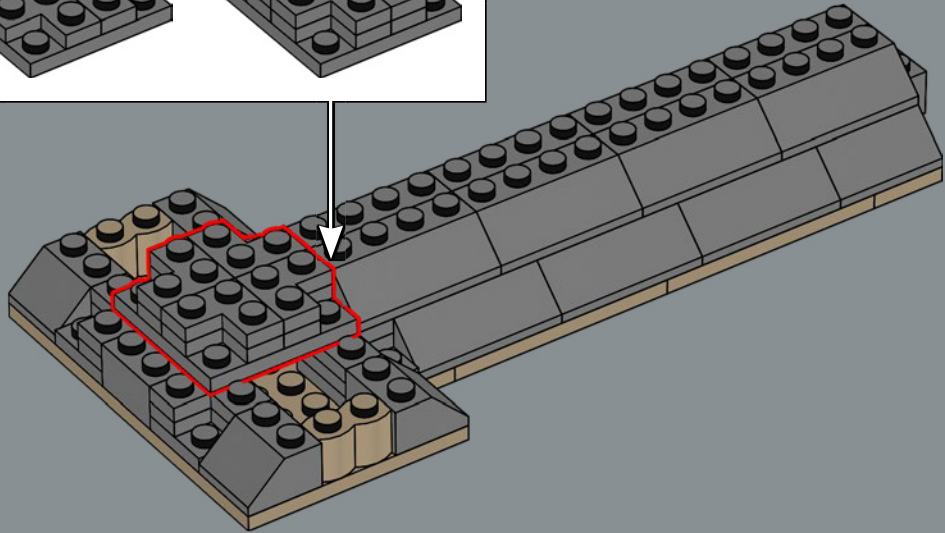
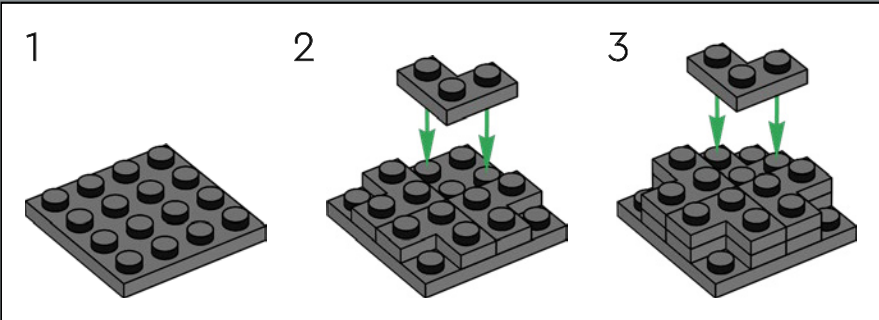

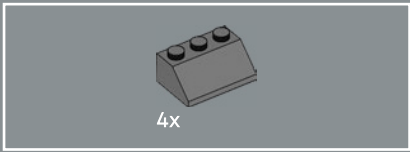

310

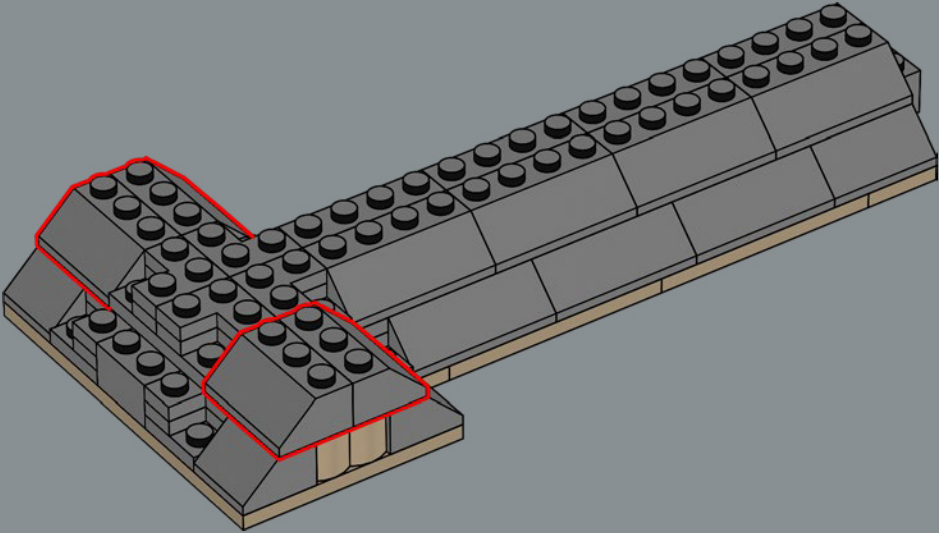

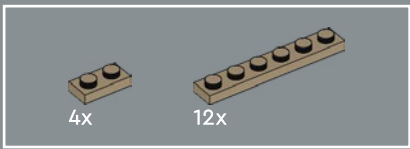

311

1

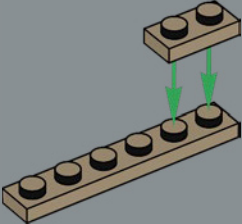

2

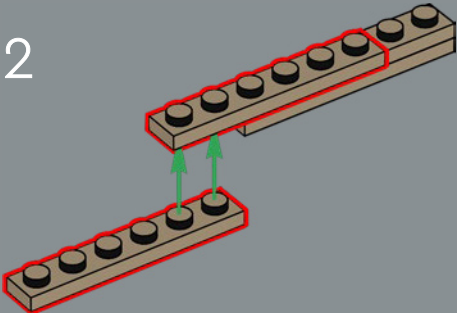

3

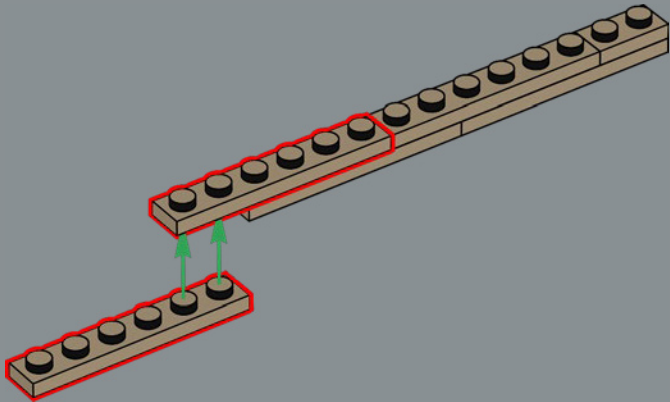

4

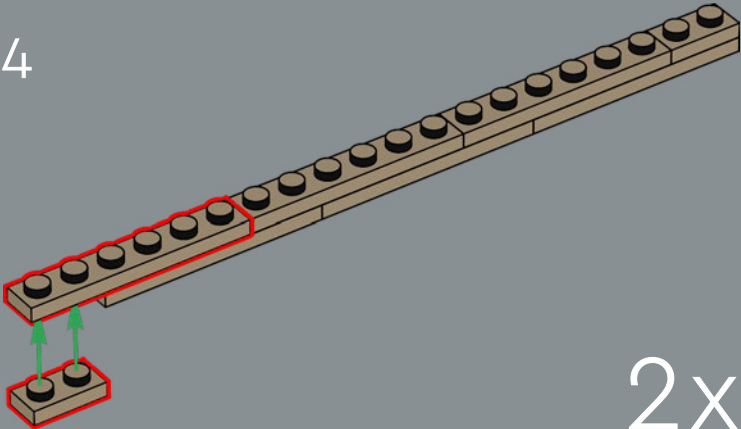

2x

Le bois qui a servi à ériger la structure en bois de la cathédrale provenait de près de 1 300 chênes, ce qui représente environ 21 hectares de forêt !

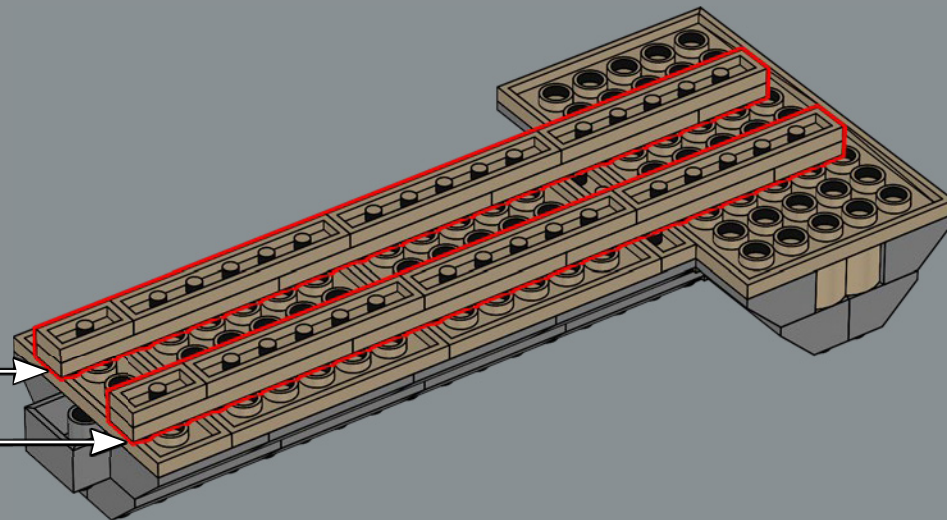



8x

312

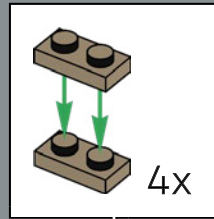

4x

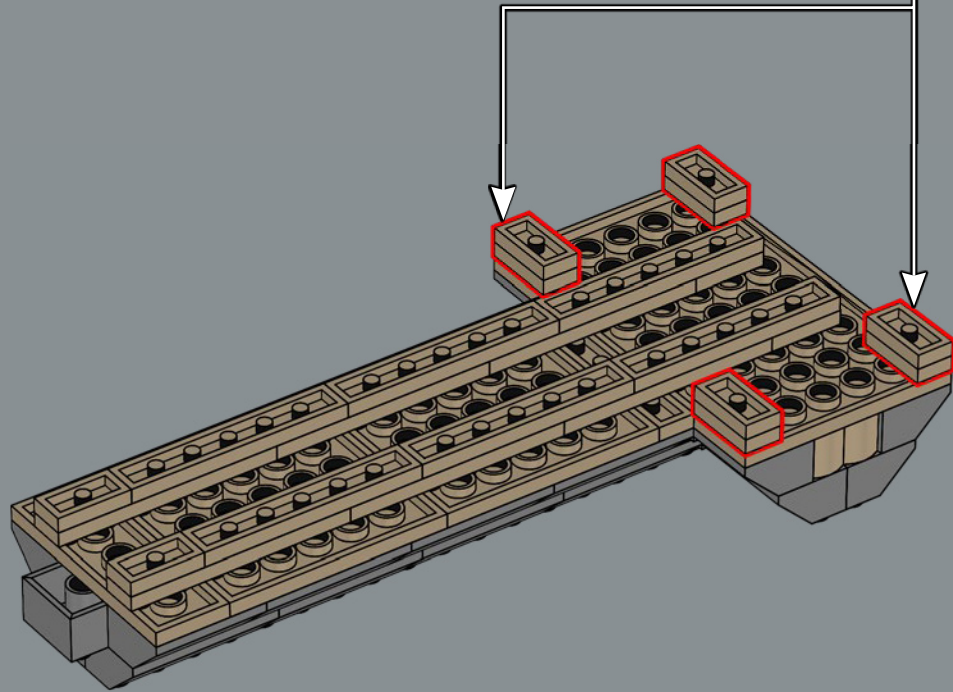

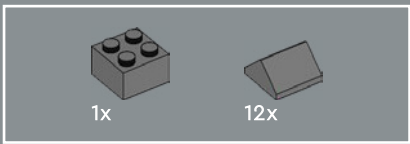

313

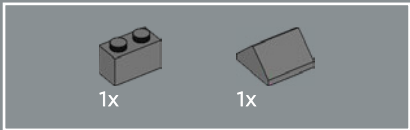
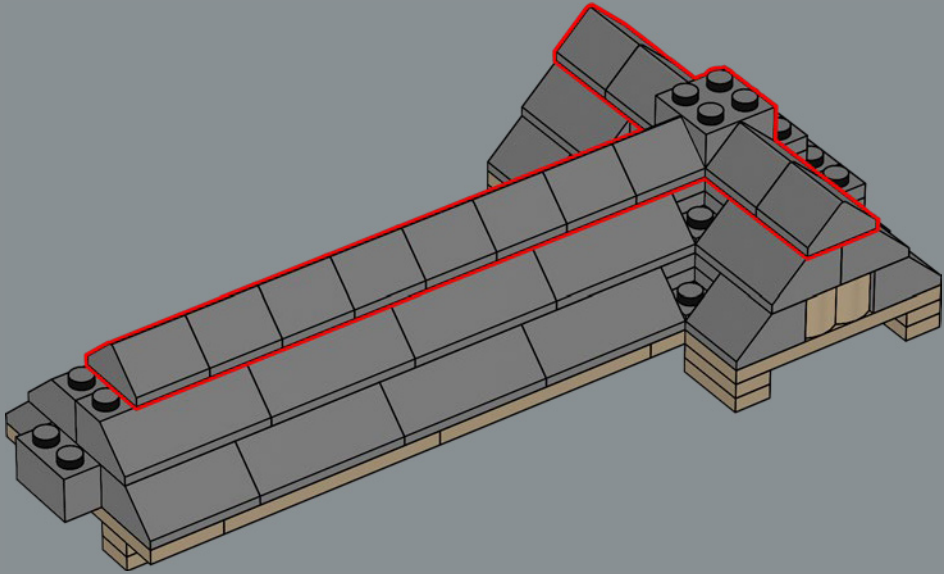

314

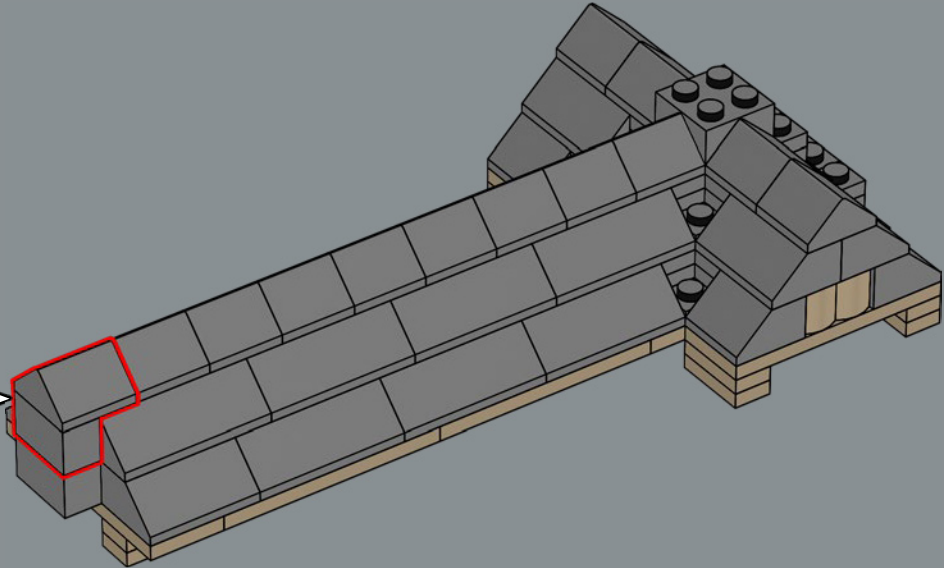
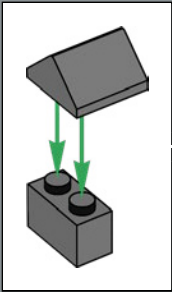

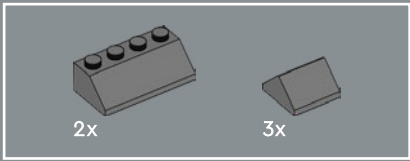

315

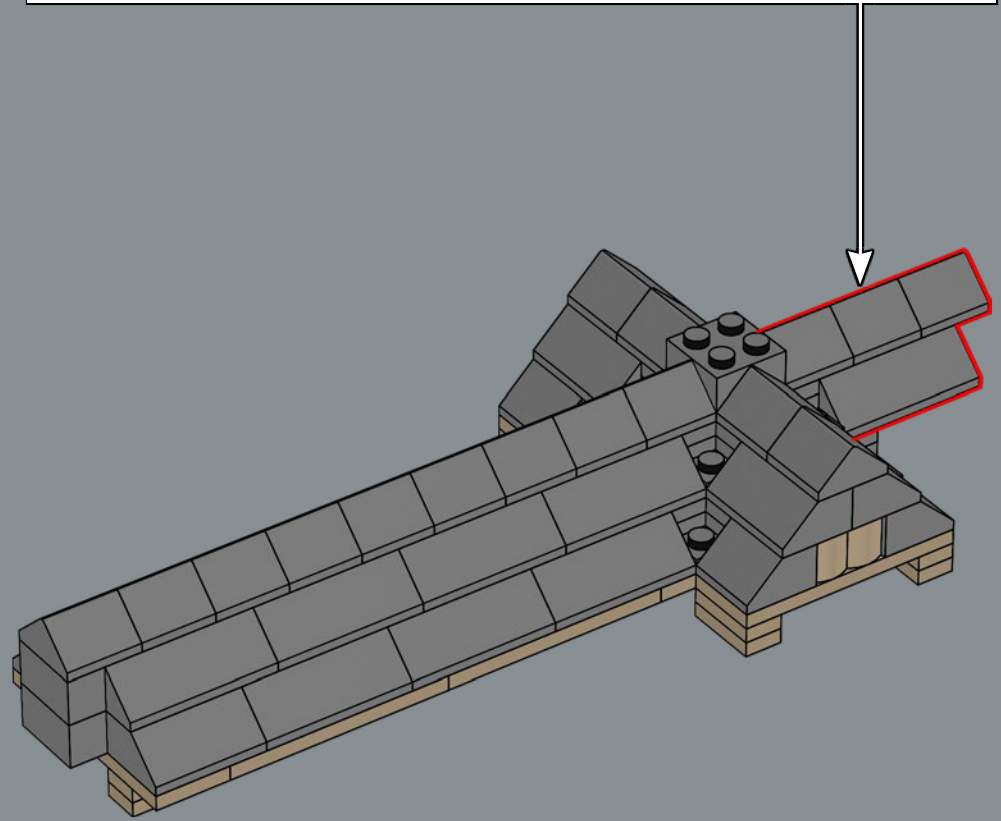
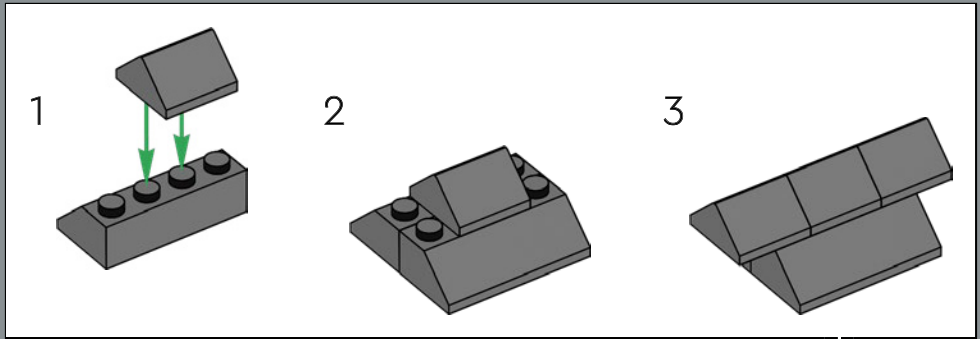

316

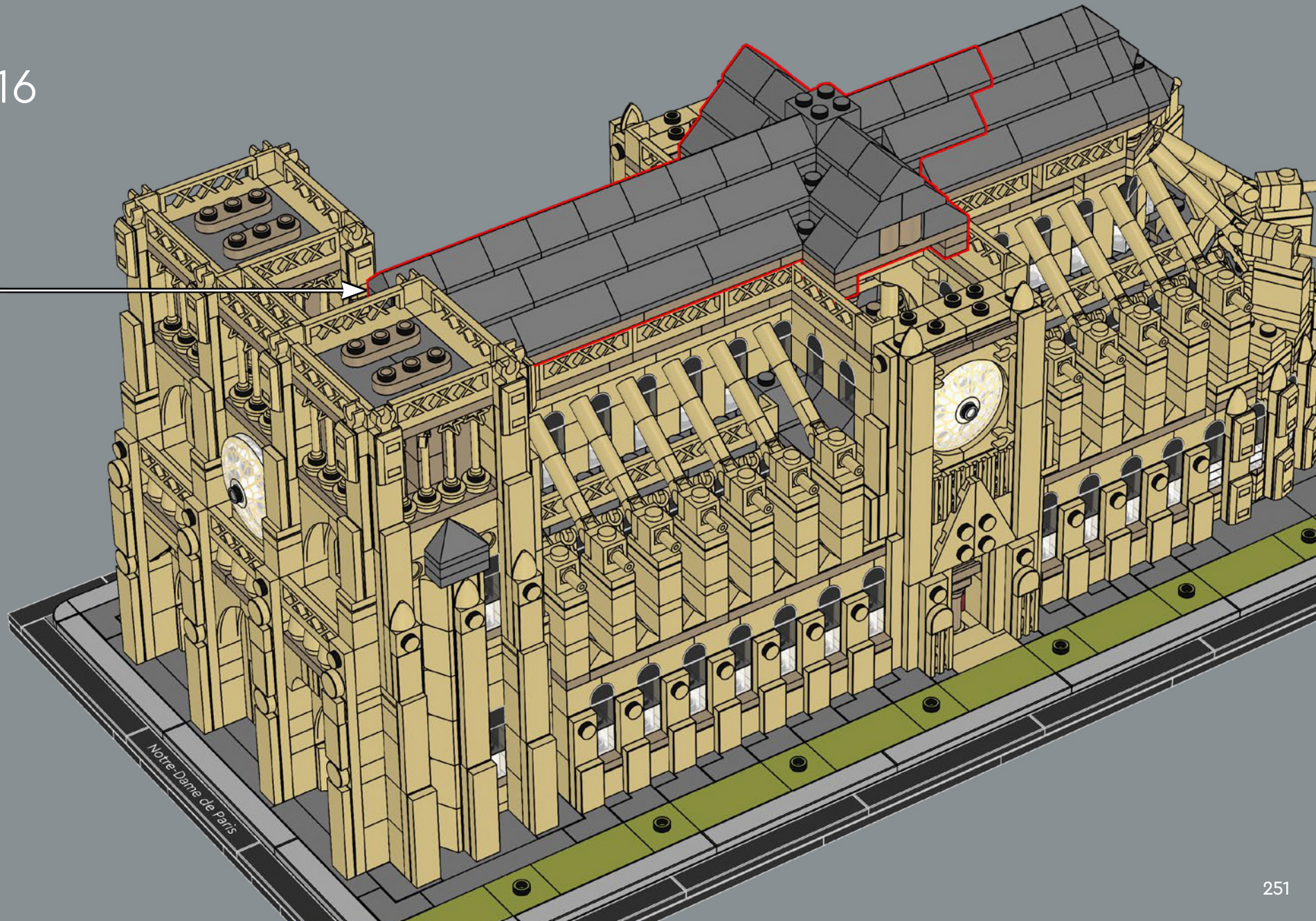

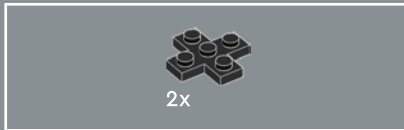
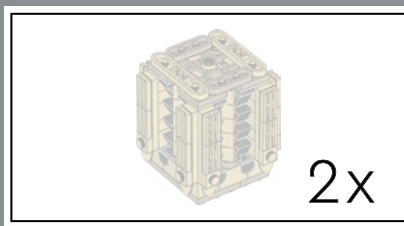

317

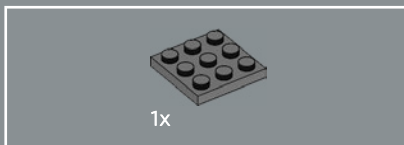
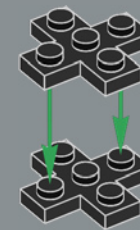

318

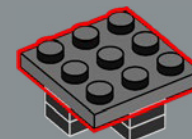

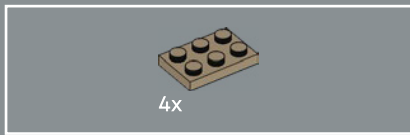

319

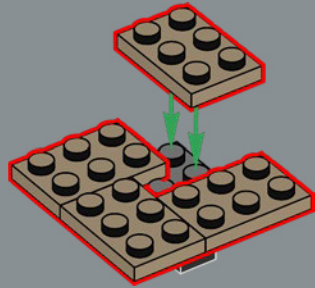

320

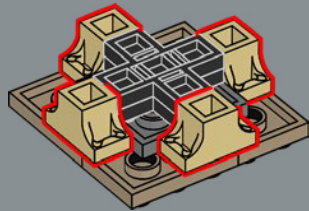

321

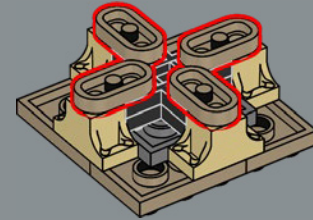

322

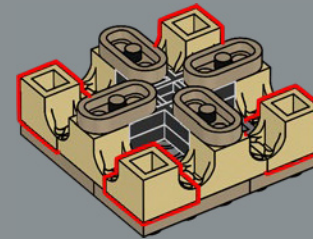



323

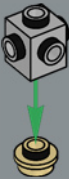

324

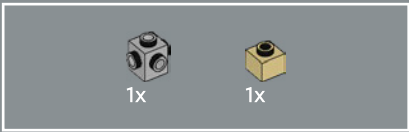

325



326



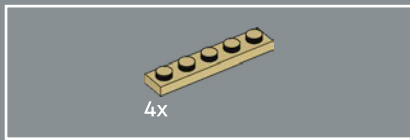

327

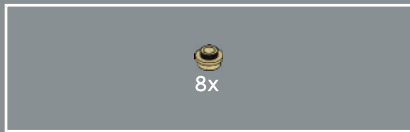
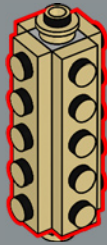

328

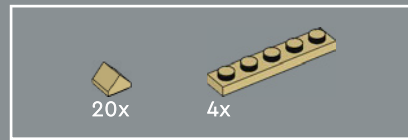
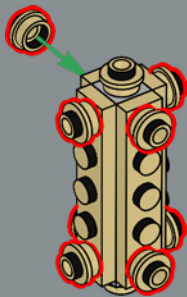

329

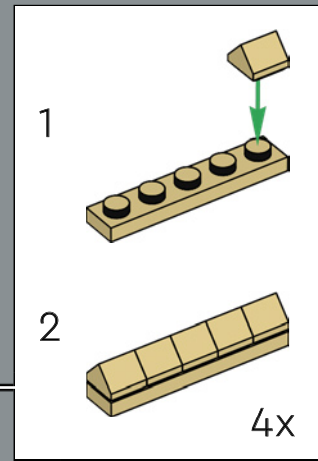
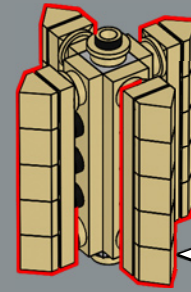

330

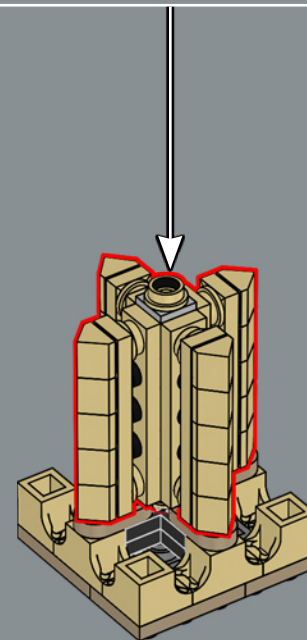

2x



331

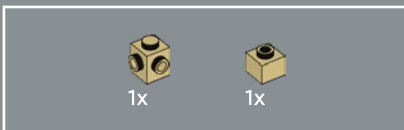

332

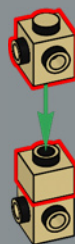

333



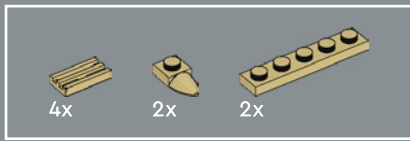

334

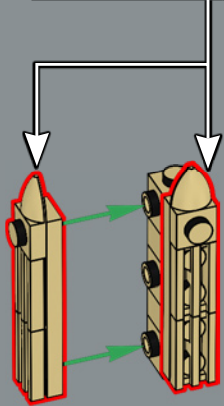
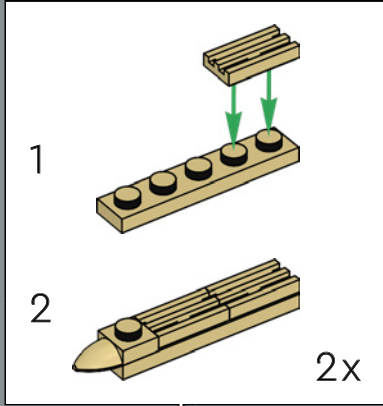

335

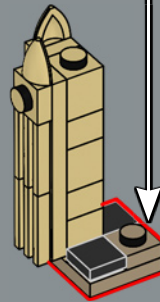
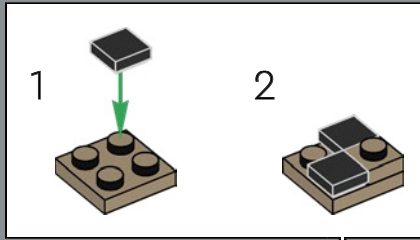

336

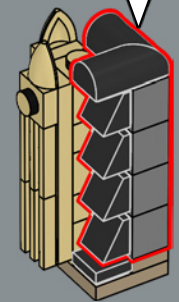
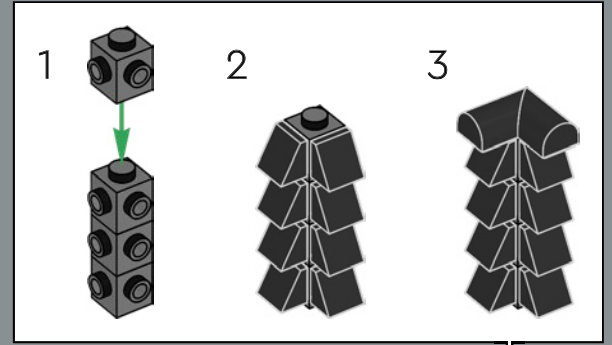

4x

337

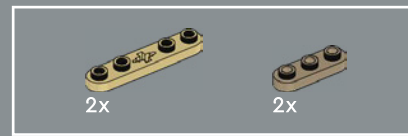
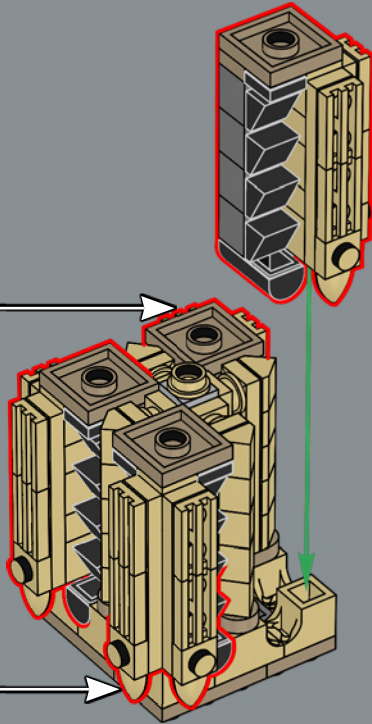

338

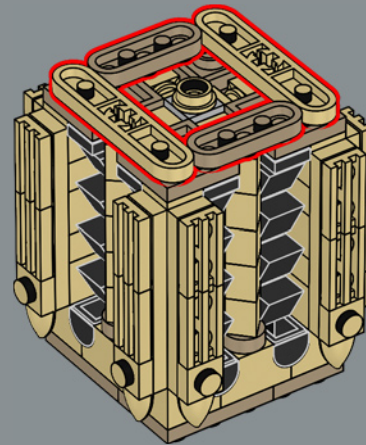

2x

Les tours abritent les cloches légendaires de la cathédrale. Elles ont d'abord été installées dans la tour nord, également connue sous le nom de Grosse tour ou « tour Guillaume ».

339

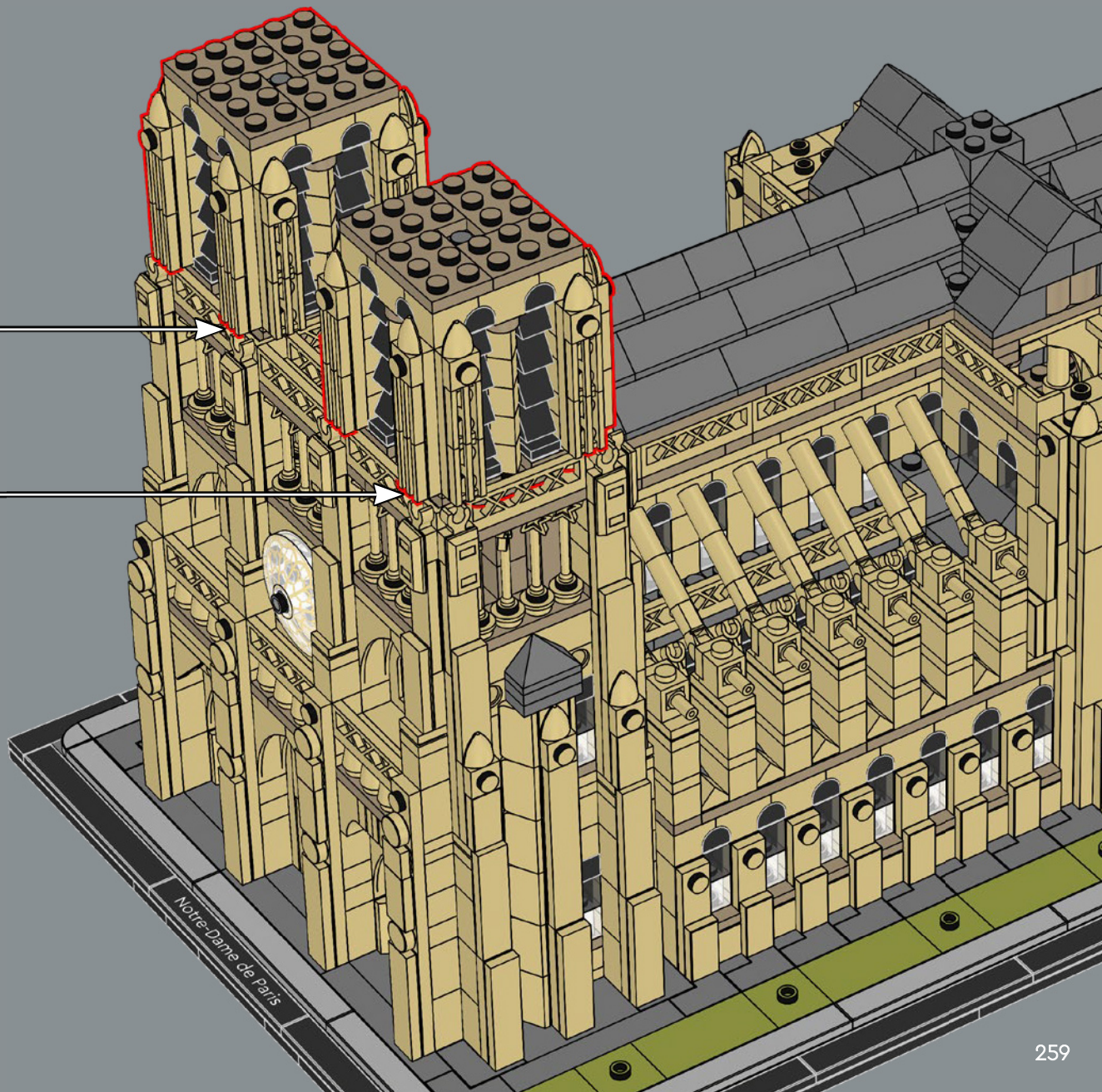



340

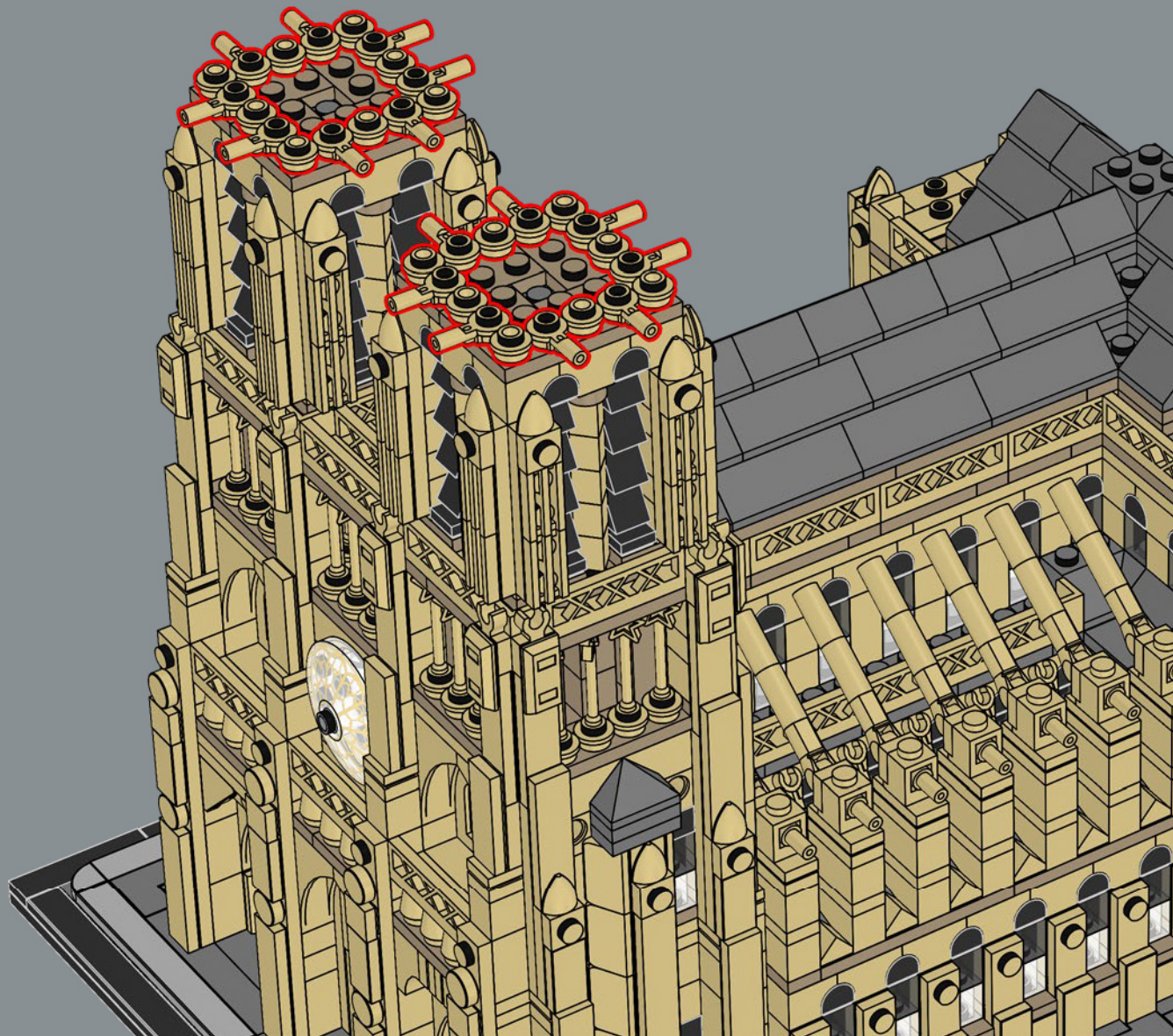

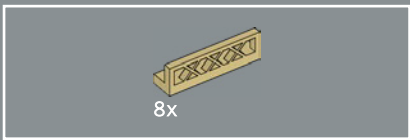

341

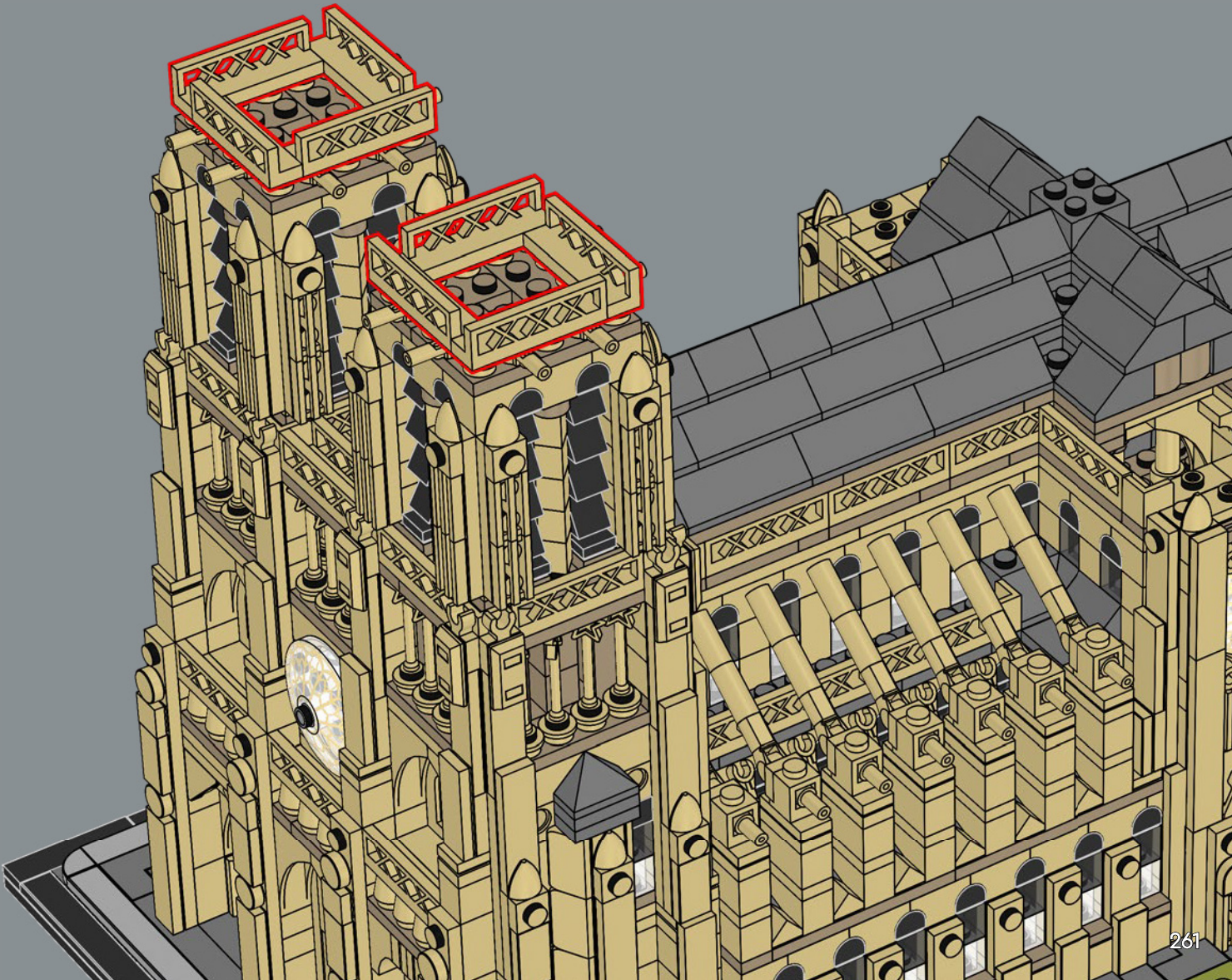

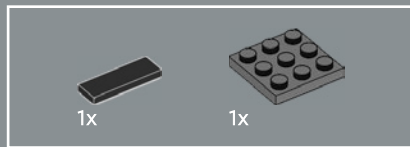
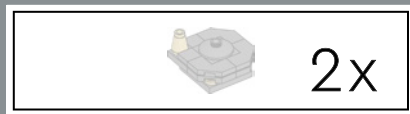

342

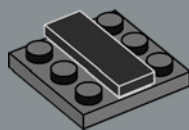

343

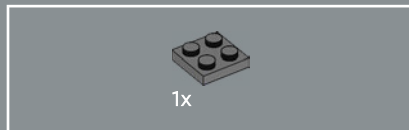
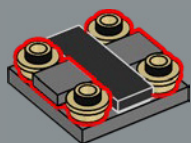

344

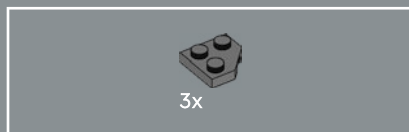
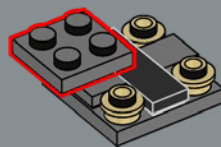

345

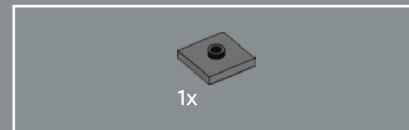
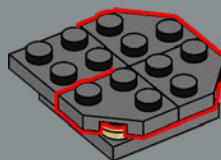

346

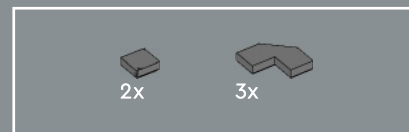
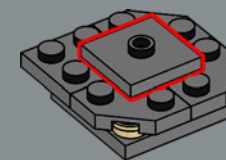

347

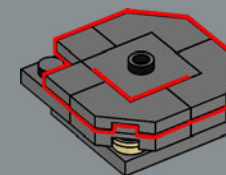



348

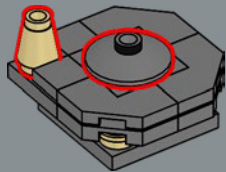

2x

349

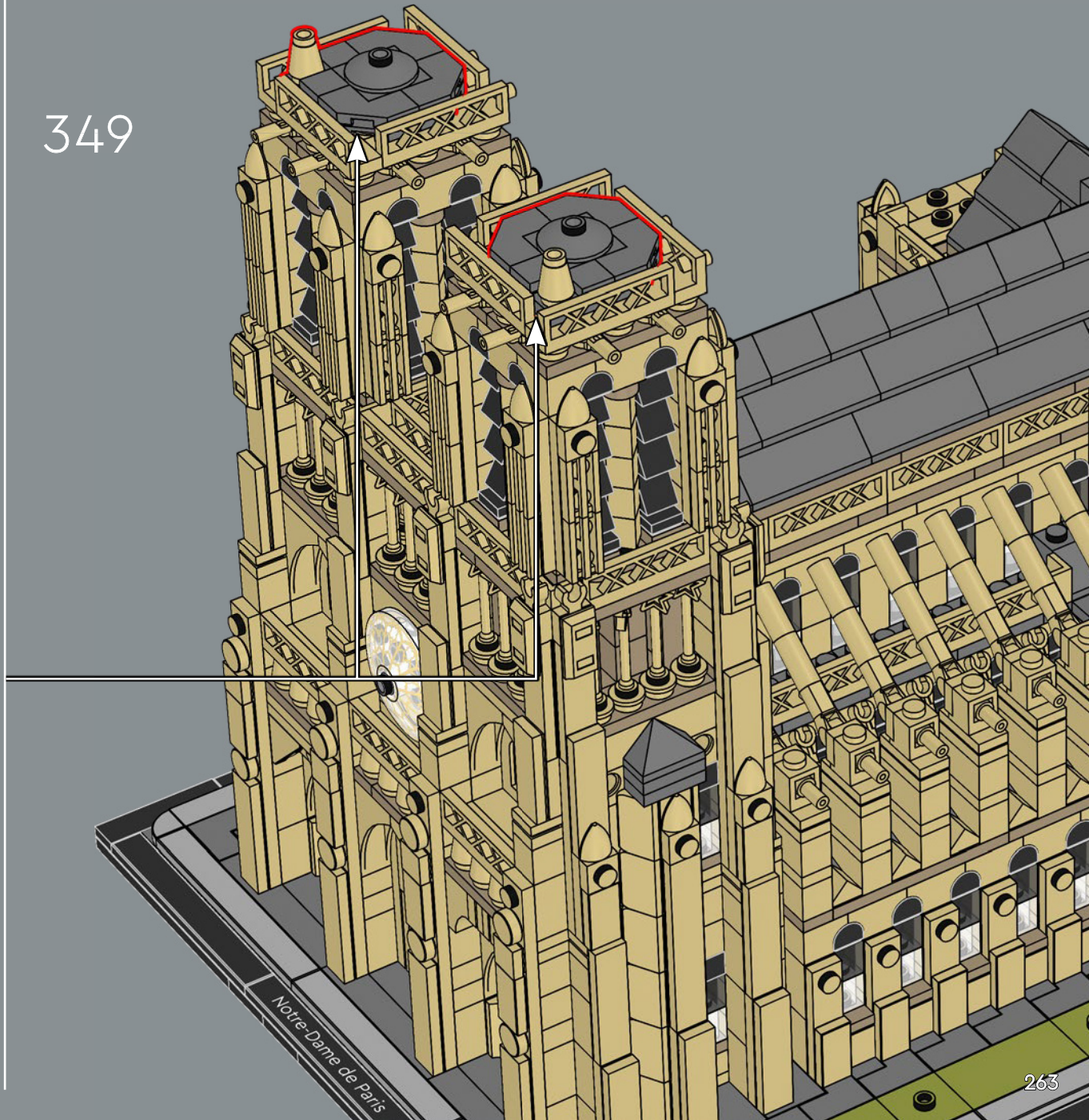

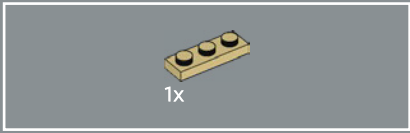
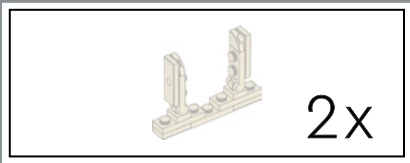

350

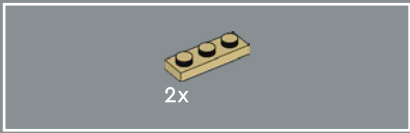
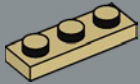

351

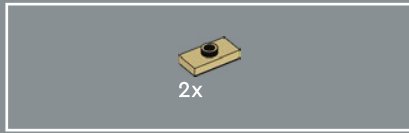
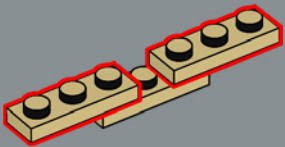

352

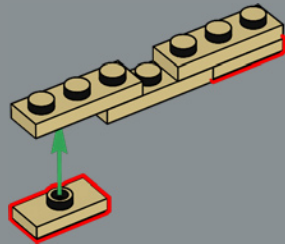

353

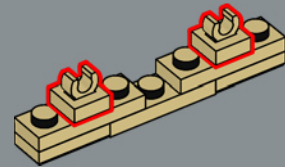

354

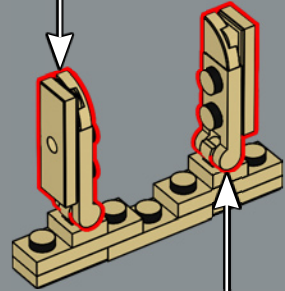
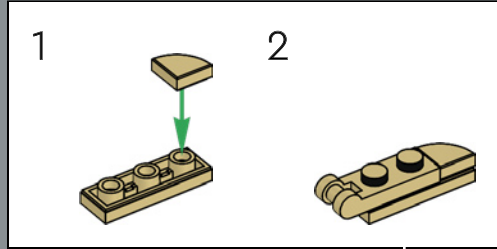

2x

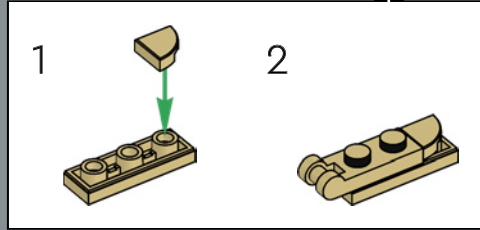

355



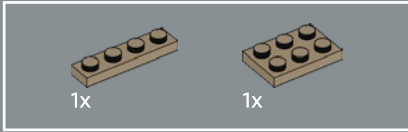
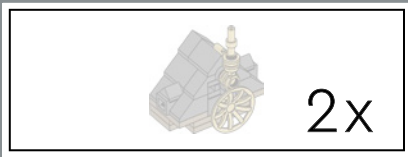

356

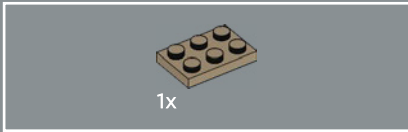
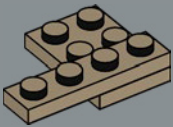

357

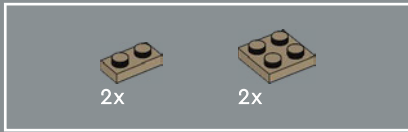
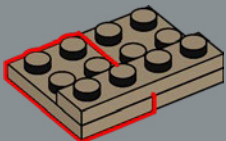

358

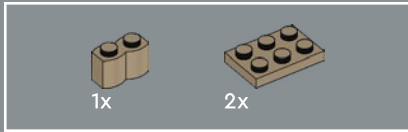
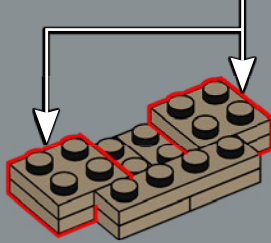
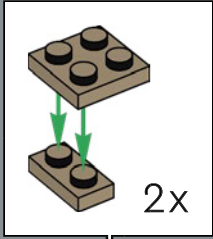

359

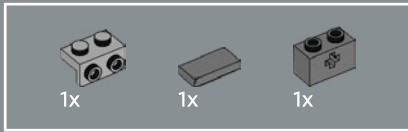
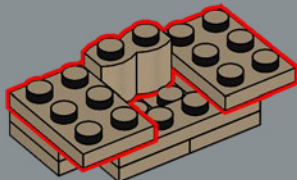

360

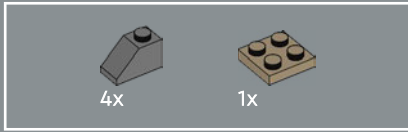
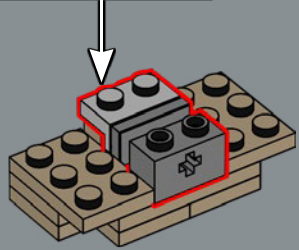
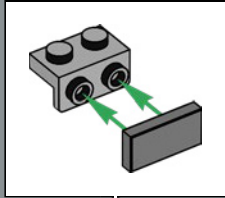

361

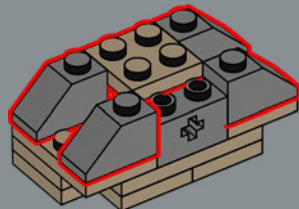

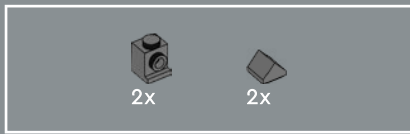

362

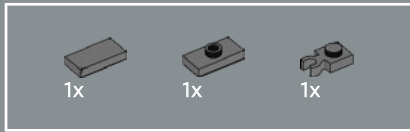
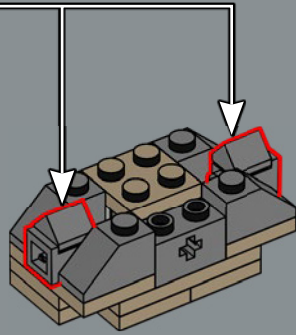
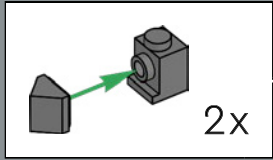

363

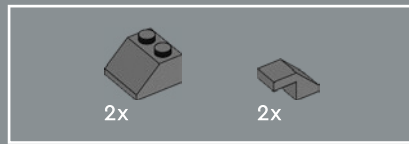
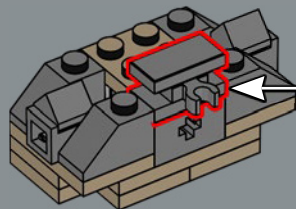
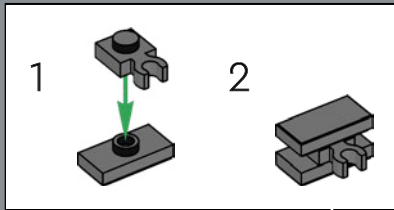

364

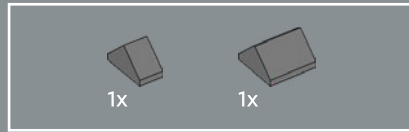
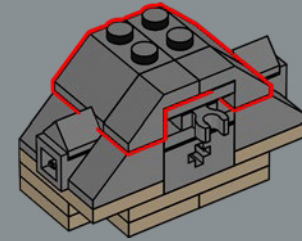

365

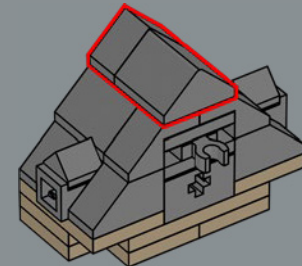



366

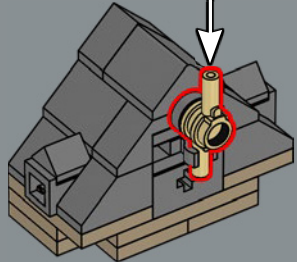
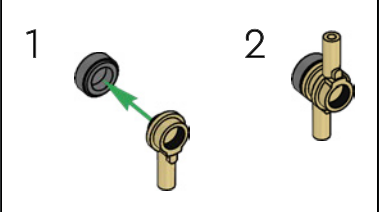

367

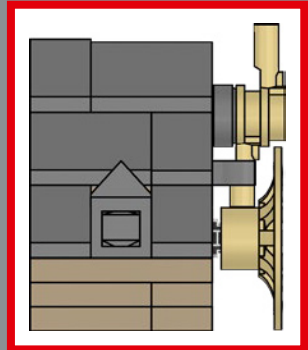
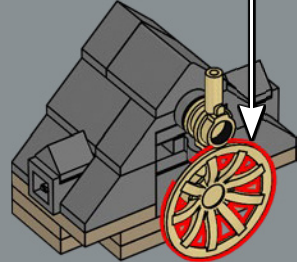
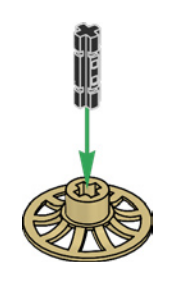

Les rosaces de plus petites dimensions sont représentées par des éléments d'enjoliveurs LEGO®.



368

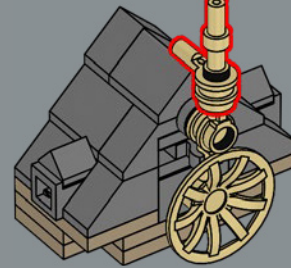
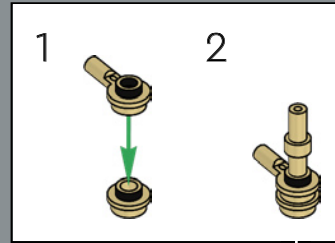

2x

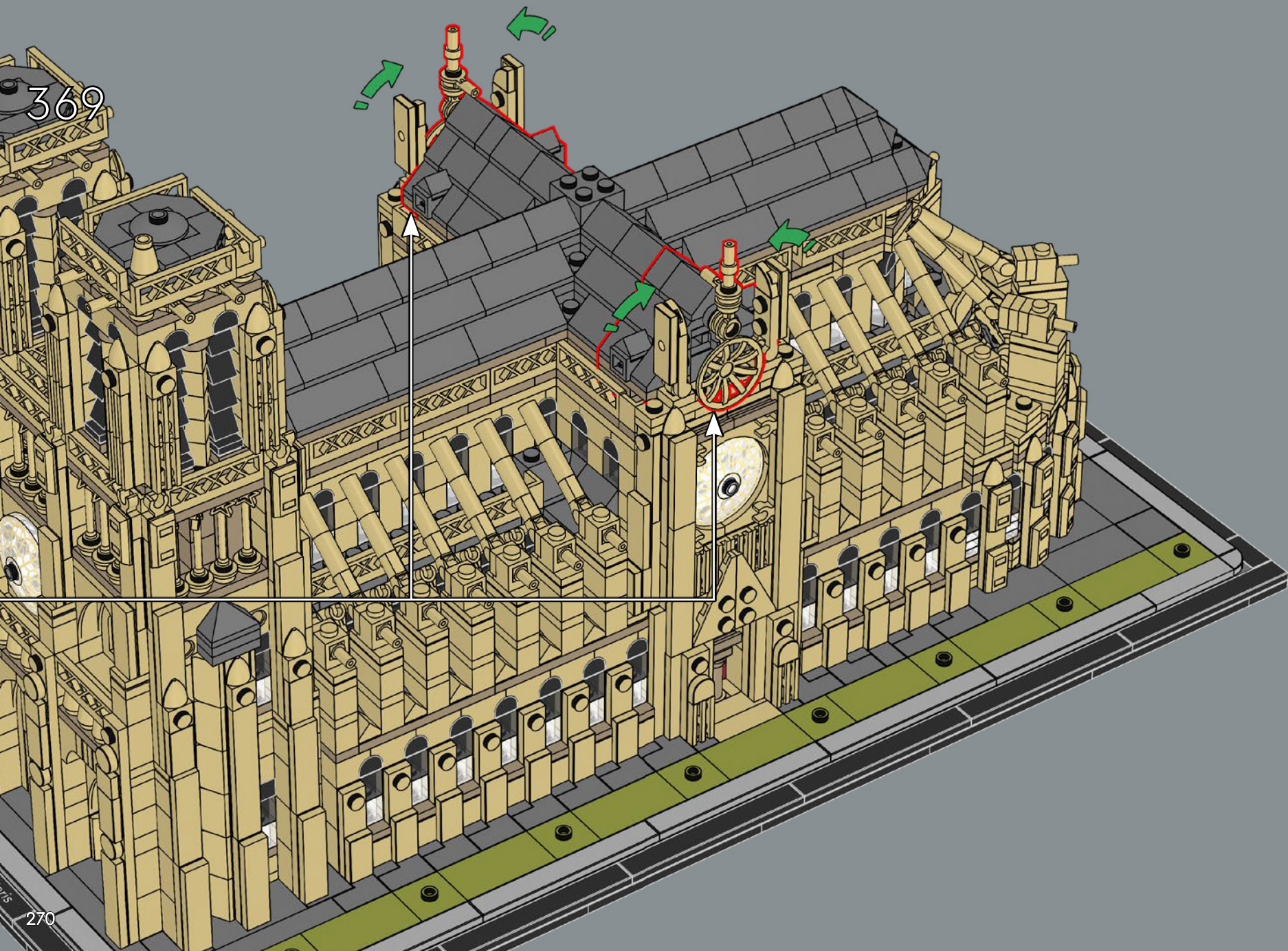

369

1245 – Les modifications se poursuivent et des chapelles latérales sont ajoutées le long de la nef.

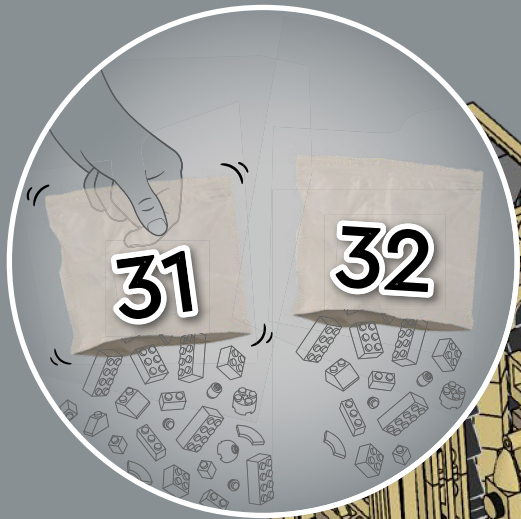
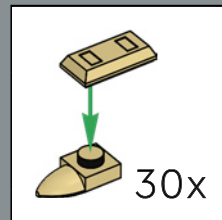

1789-1860



RÉVOLUTION ET HÉRITAGE CULTUREL

✂ Pendant les années agitées de la Révolution française (1789-1799), la noble cathédrale Notre-Dame subit des dommages et commence à se dégrader. Les rosaces, les autels et les tombes sont détruits, les cloches sont brisées et fondues. En 1792, des émeutiers détruisent les statues de la Galerie des Rois et démontent la flèche. Pendant quelque temps, la cathédrale sert même de lieu de stockage pour le vin et d'autres marchandises. Mais au lendemain de la Révolution, on assiste à l'émergence d'une prise de conscience et de reconnaissance du patrimoine national français. La publication du *Bossu de Notre-Dame* de Victor Hugo en 1831, ainsi que l'accueil international qui lui est réservé, ont consolidé le statut de la cathédrale en tant que joyau culturel de l'histoire mondiale. De 1843 à 1860, les architectes Jean-Baptiste Lassus et Eugène-Emmanuel Viollet-le-Duc mènent une vaste campagne de restauration de la cathédrale, qui aboutira à la version du monument historique que nous connaissons aujourd'hui.



371

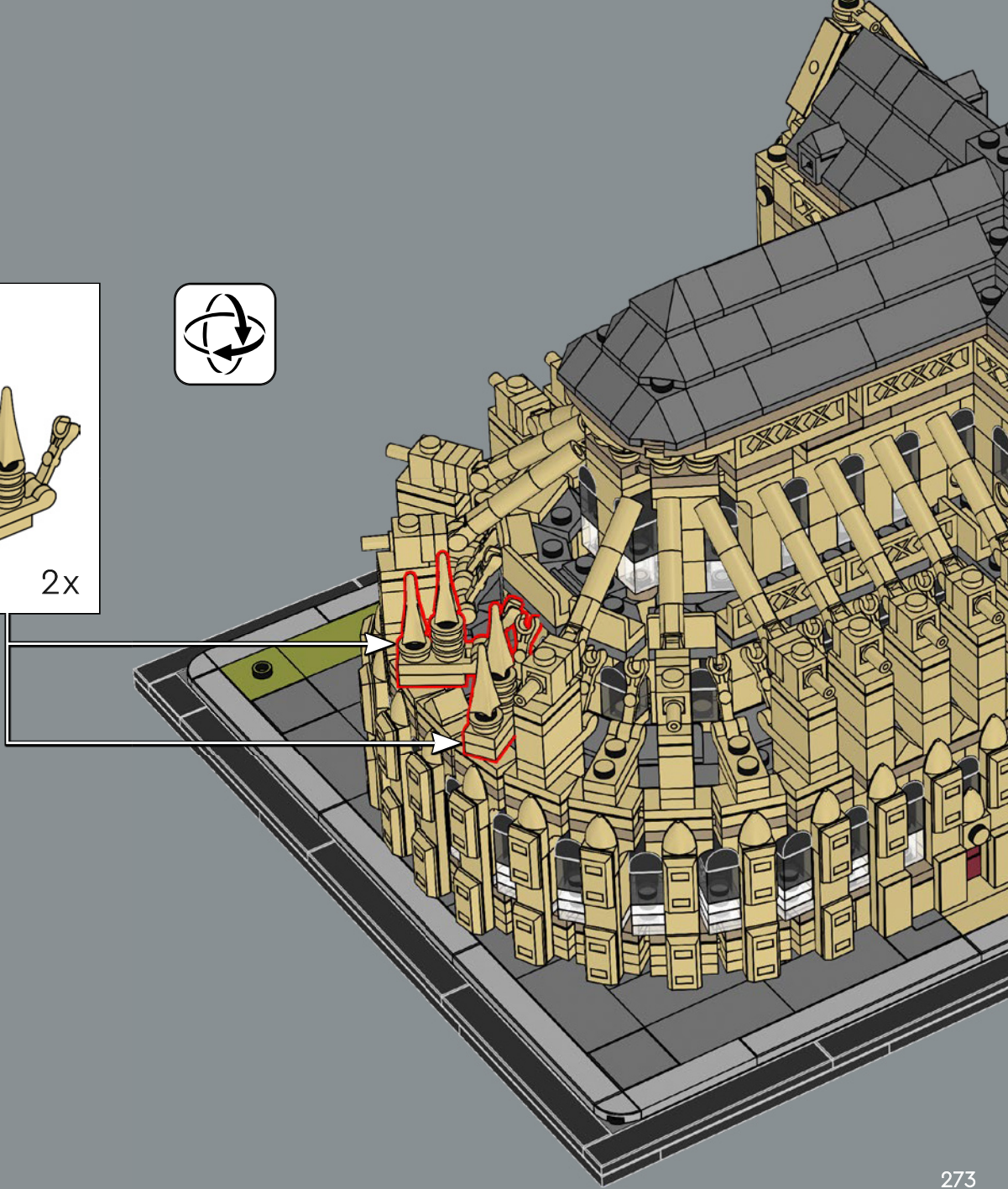
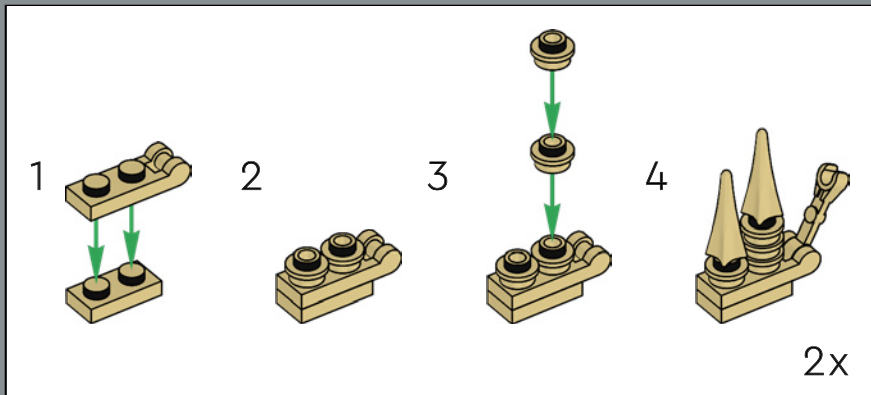



372

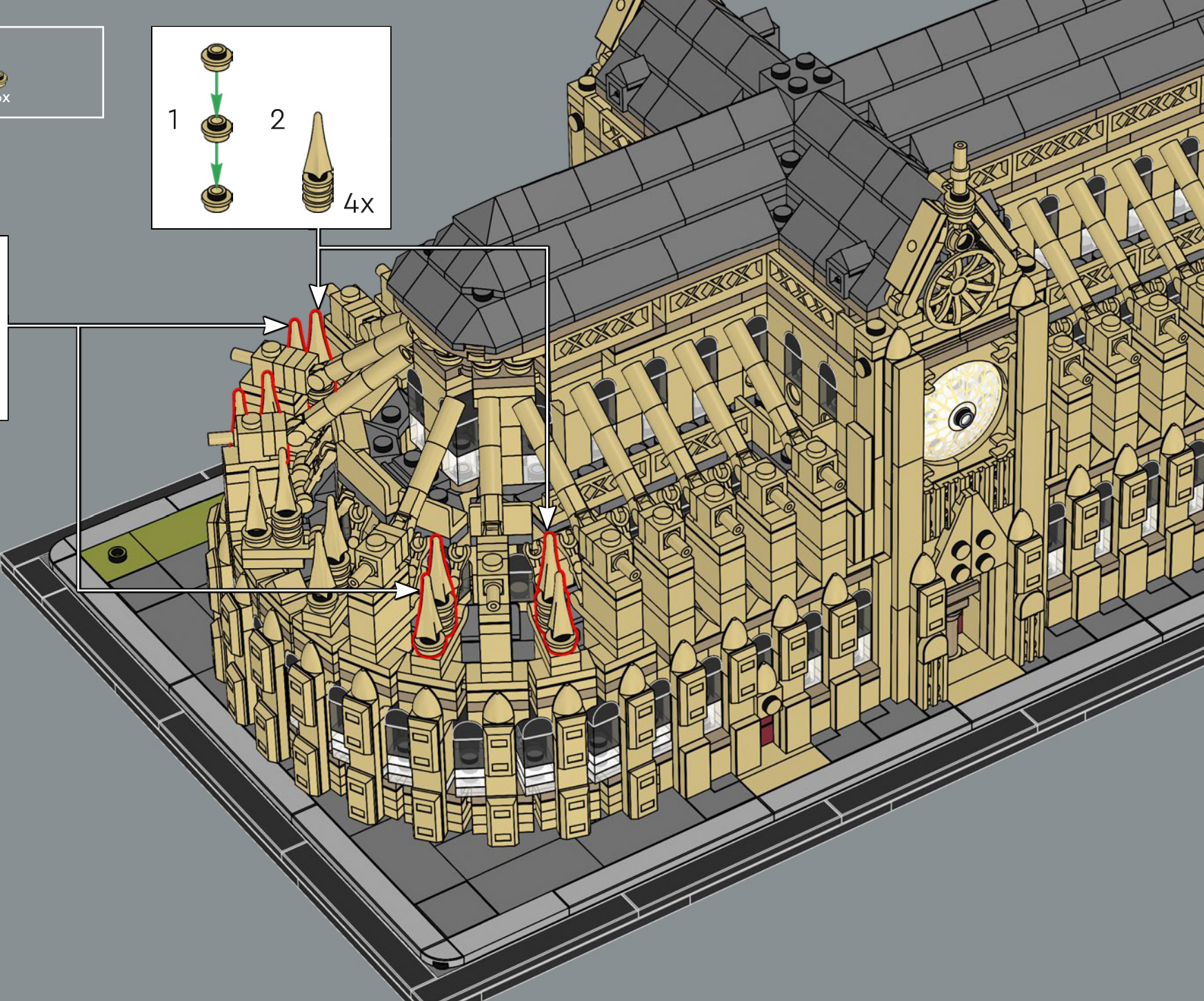
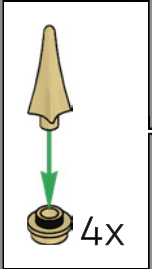
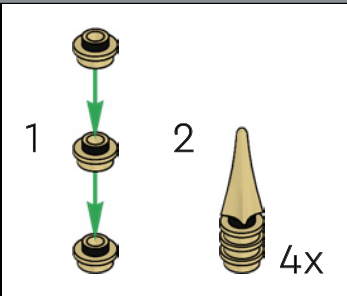



1350 – Les finitions de Notre-Dame sont terminées. Les pinacles surmontant les arcs-boutants sont reconstruits. Ils seront à nouveau remplacés au XIX^e siècle.

373

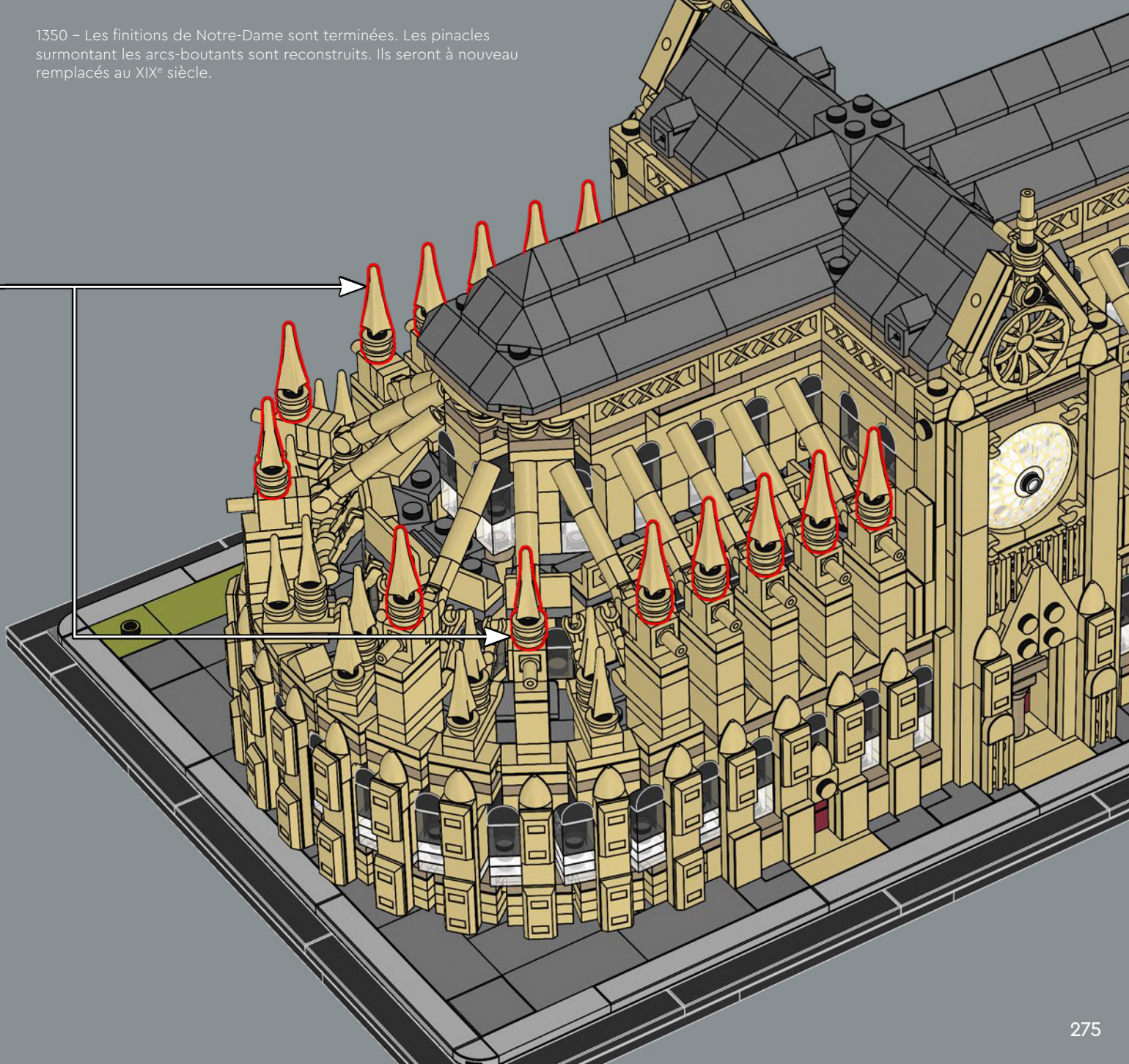
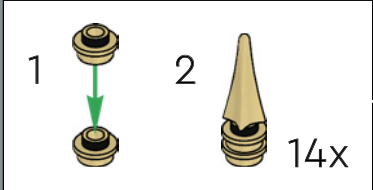



374

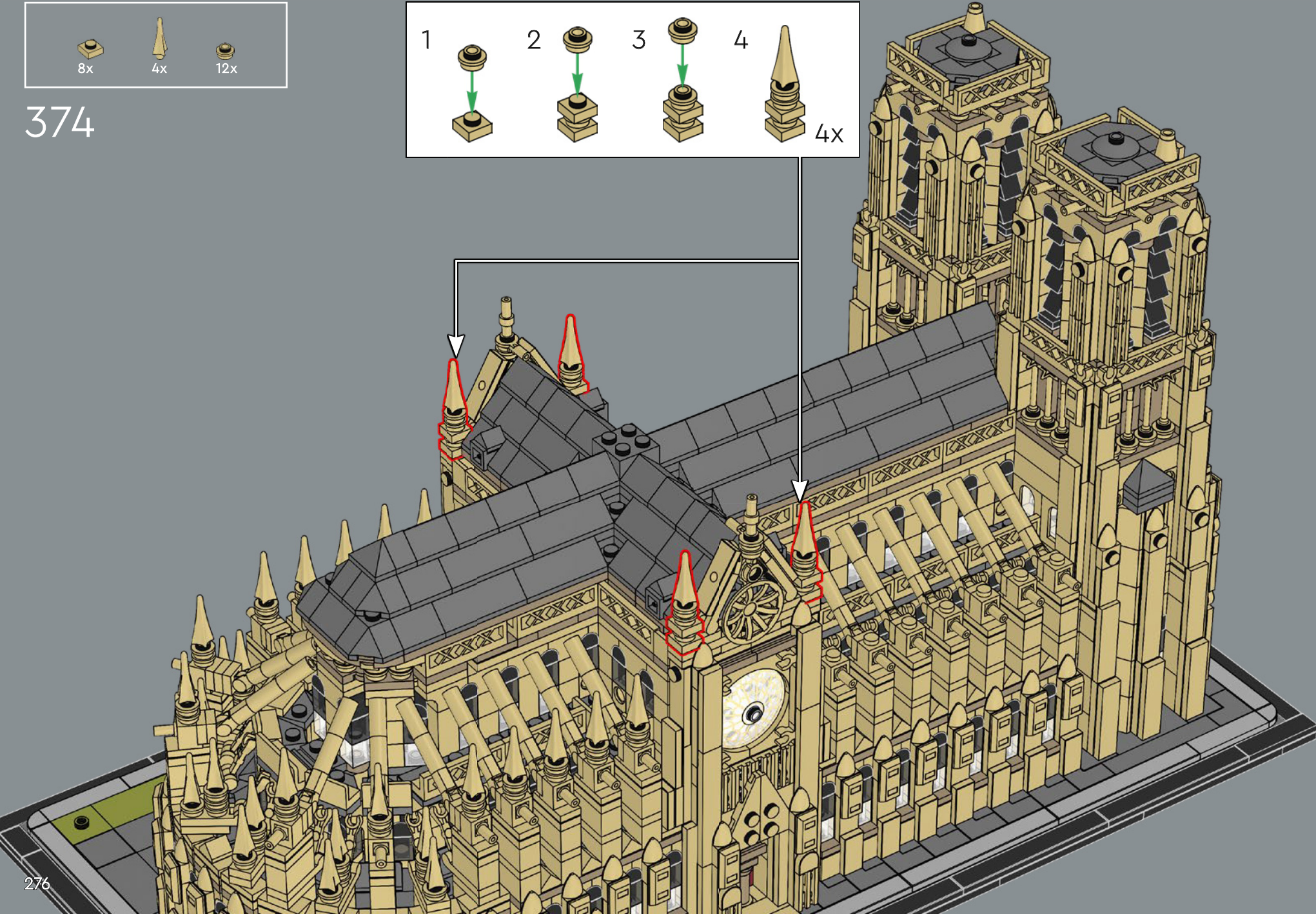
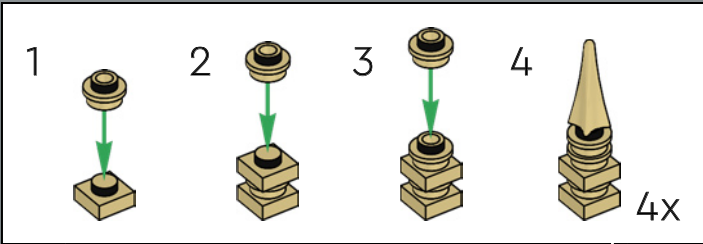



14x



14x

1858 - Des édicules en forme de tabernacles sont ajoutés sur les arcs-boutants par Jean-Baptiste Lassus et Eugène-Emmanuel Viollet-le-Duc.

375



14x

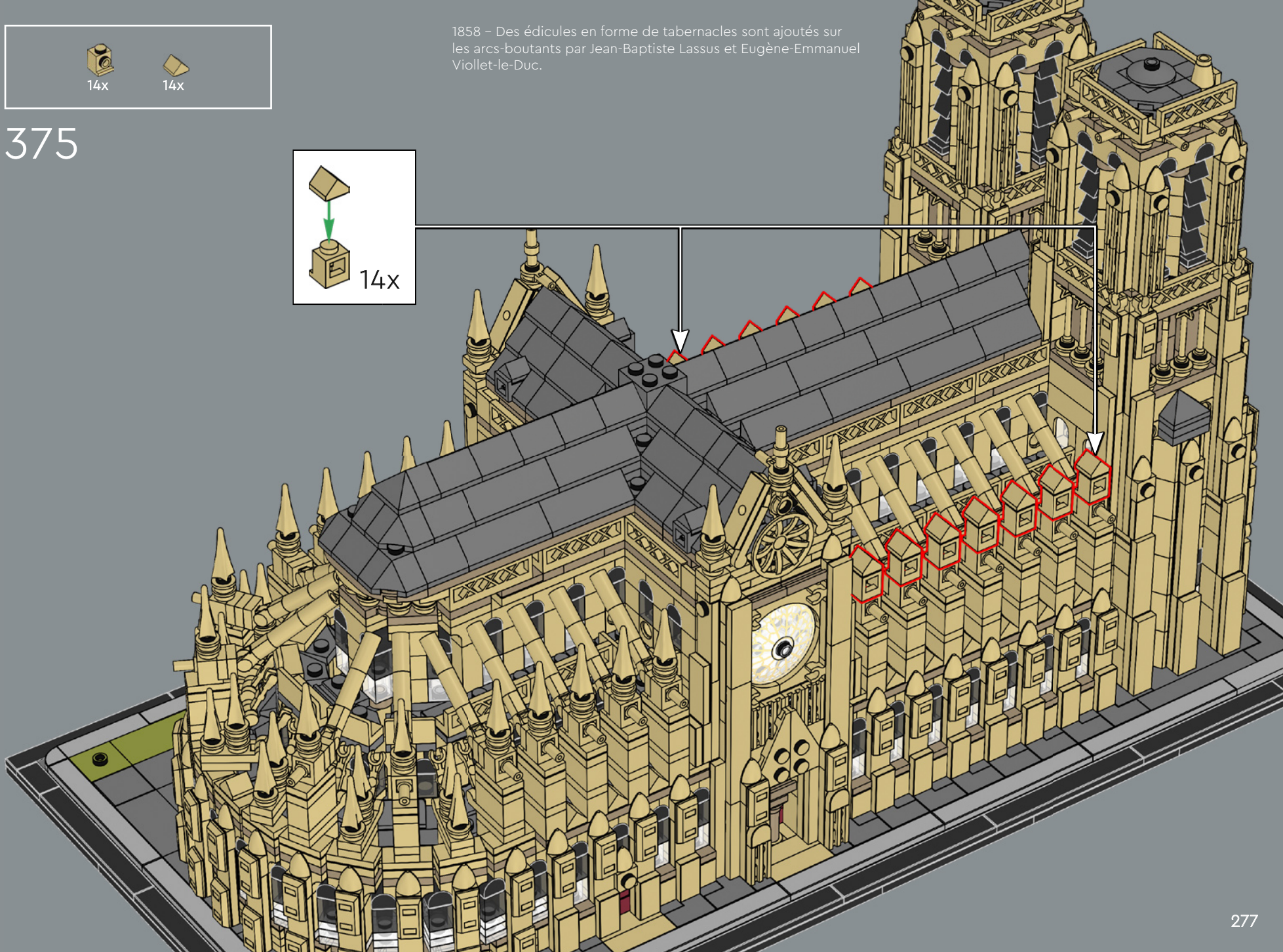

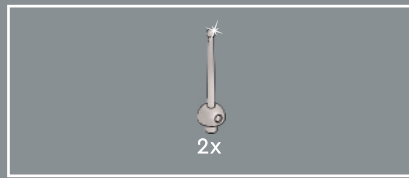

376

S'élevant à 69 m de hauteur, les deux tours de la façade occidentale font de la cathédrale Notre-Dame le plus haut édifice de Paris jusqu'à la construction de la tour Eiffel (1887-1889).

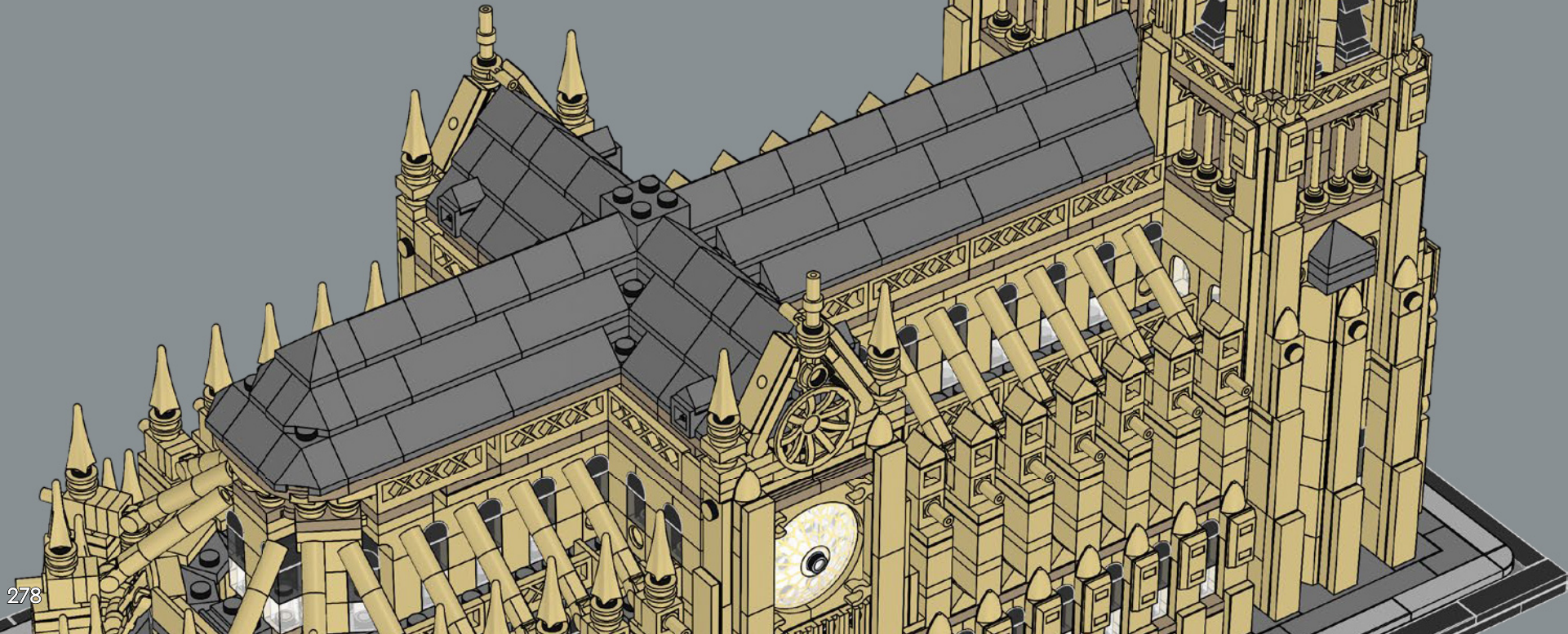



8x

377

1843-1860 – Importante restauration par Jean-Baptiste Lassus et Eugène-Emmanuel Viollet-le-Duc.

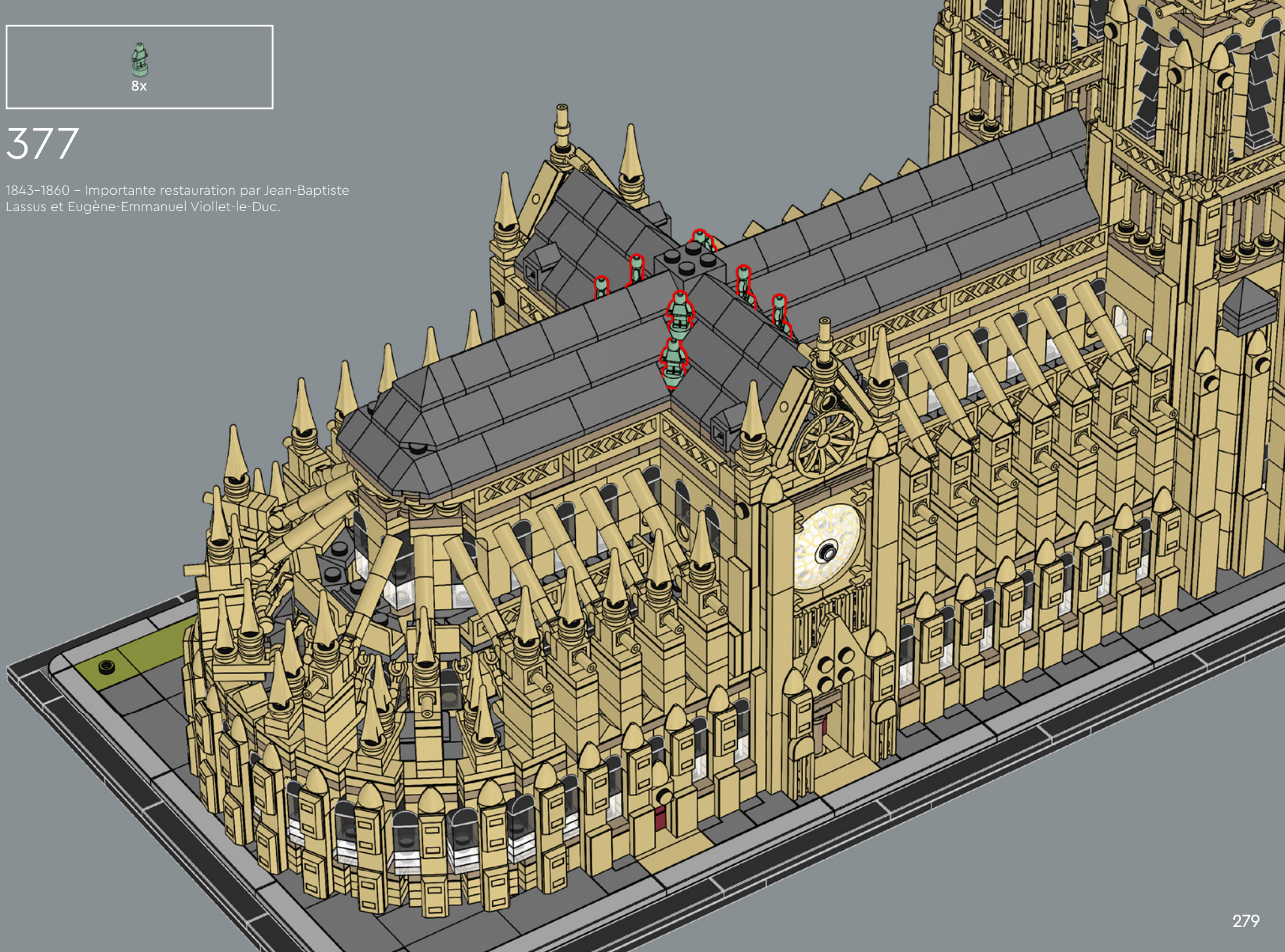

- 2x
- 1x
- 1x
- 8x



378

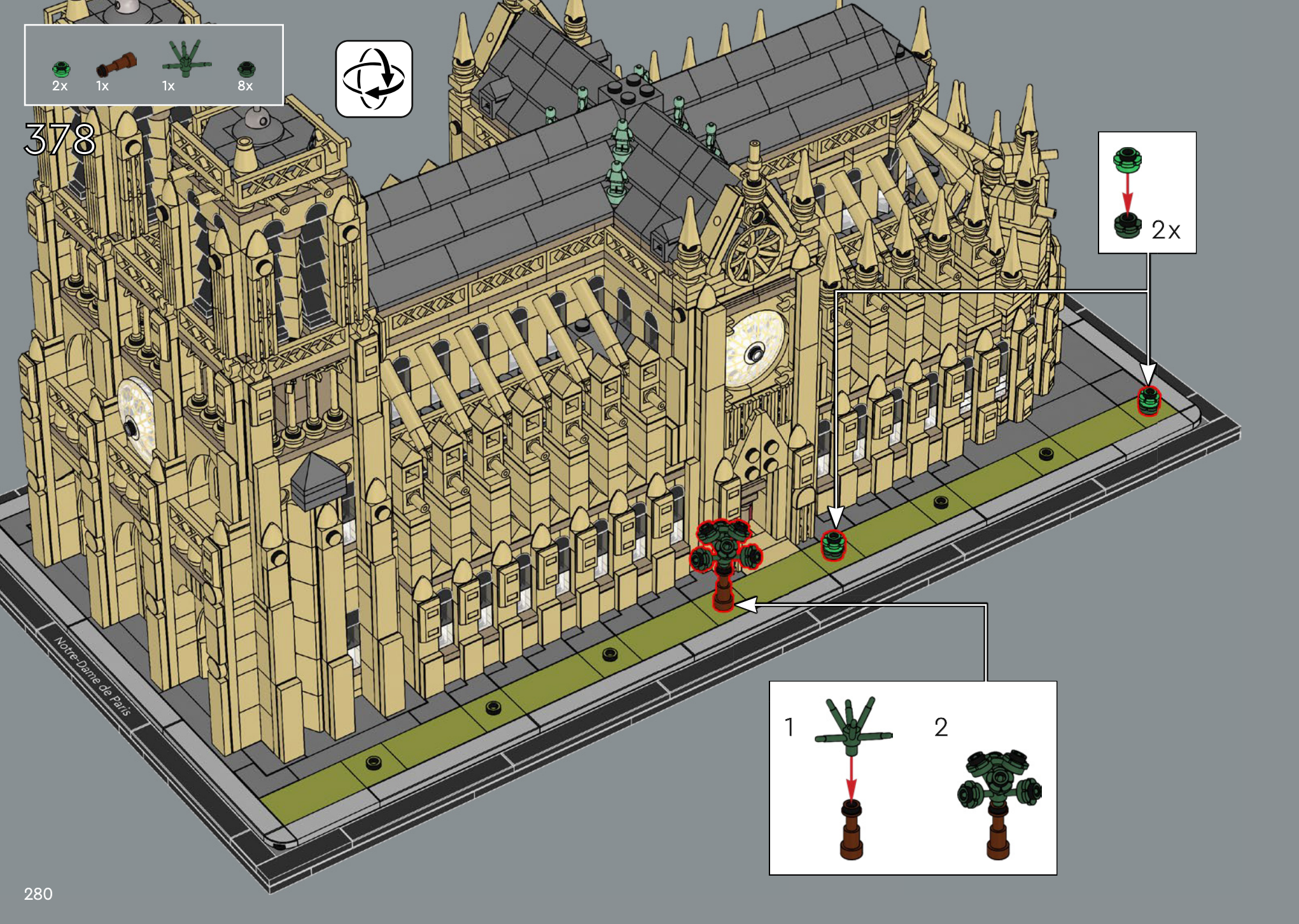
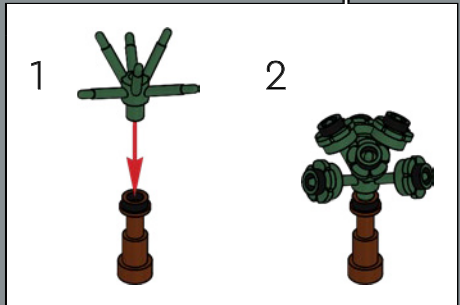
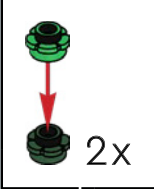

18x 3x 3x

379



1 2

1. A green canopy with five branches is shown above a brown stem. A red arrow points from the canopy to the stem, indicating the direction of assembly.

2. The green canopy is now attached to the brown stem, forming a complete tree.

3x

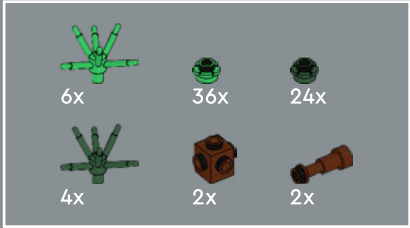
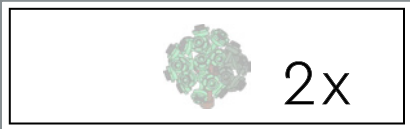

380

Dimensions actuelles de la cathédrale Notre-Dame :
Largeur de la façade : 43,5 m. Largeur du transept : 48 m.
Longueur totale : 128 m. Hauteur de la flèche : 96 m.
Hauteur des tours : 69 m. Hauteur du toit de la nef : 35 m.

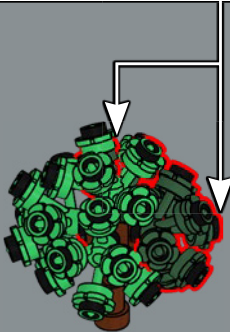
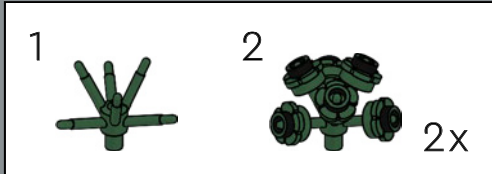
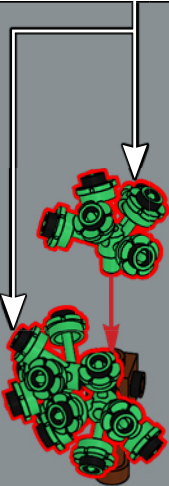
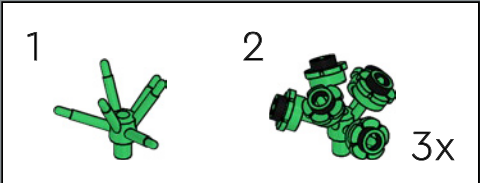

2x



Notre-Dame de Paris

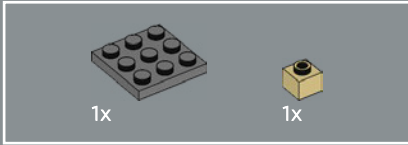
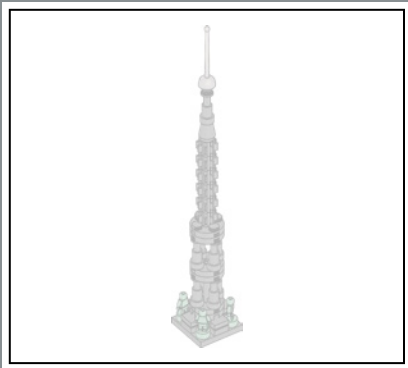

381

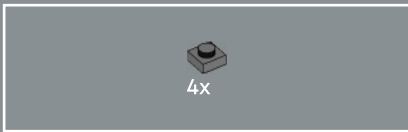
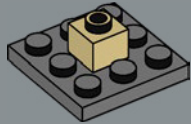

382

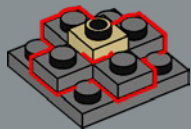

383

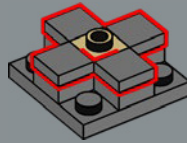

384

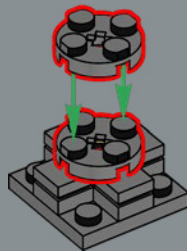

385

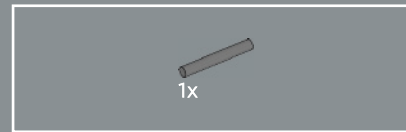
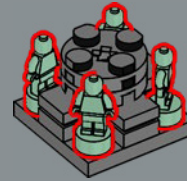

386

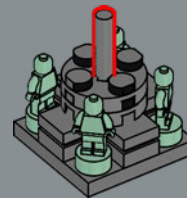



387

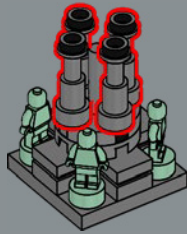

389

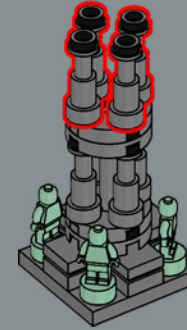

388

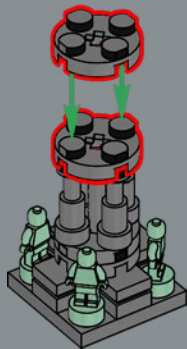

390

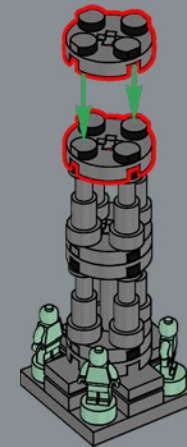

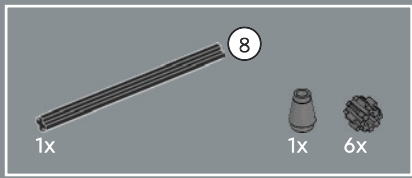

391

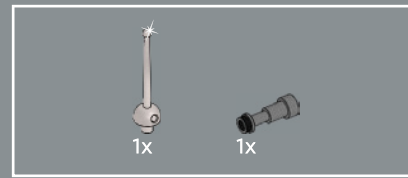
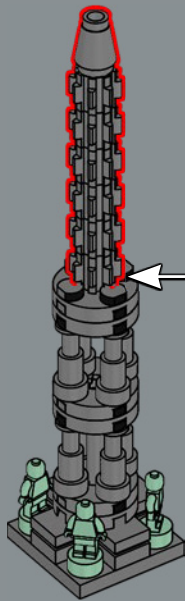
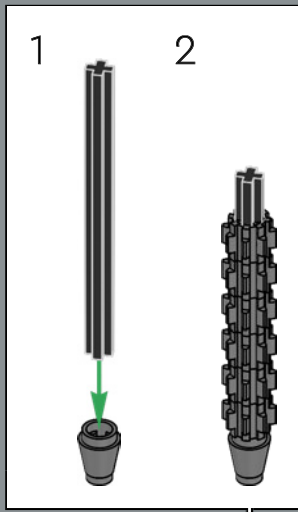

392

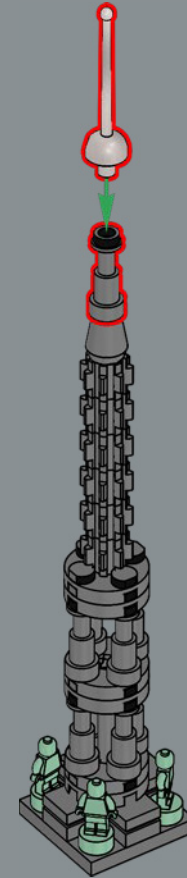

Les portes d'entrée de la version LEGO® de la cathédrale Notre-Dame sont ouvertes pour nous permettre de jeter un coup d'œil à l'intérieur et de nous laisser envahir par le sentiment d'admiration que l'on peut éprouver en pénétrant dans ce vaste espace voûté aux détails complexes.

393

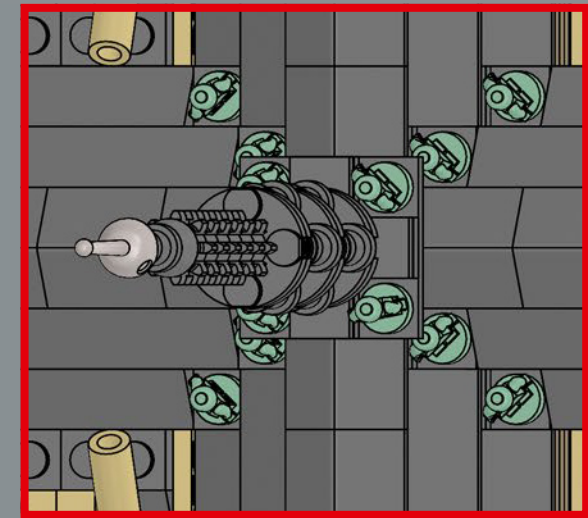

L'unique statue faisant face à la flèche porte le visage d'Eugène-Emmanuel Viollet-le-Duc, l'un des architectes de la cathédrale. Il contemple la flèche et admire l'édifice, tandis que les autres veillent sur Paris.



INCENDIE ET RECONSTRUCTION

Après l'incendie dévastateur d'avril 2019, la cathédrale Notre-Dame est contrainte de fermer ses portes pour une durée indéterminée, en attendant sa reconstruction. Alors que le monde entier regarde les secouristes lutter contre l'incendie, des campagnes mondiales de collecte de fonds permettent de recueillir en un temps record de généreuses contributions aux vastes efforts de reconstruction. Un témoignage du souvenir indélébile que la cathédrale Notre-Dame a laissé aux personnes de toutes cultures tout au long de sa vie, et de l'esprit incomparable de Paris. Recréant près de 900 ans d'histoire avec plus de 4 000 éléments LEGO®, nous sommes ravis d'enrichir notre collection LEGO Architecture avec ce modèle.





6x
4616711



80x
6300322



8x
6231386



12x
6449564



1x
6167854



2x
6300321



8x
6458397



32x
6446790



5x
6398343



5x
6264025



1x
6341471



2x
6133765



7x
6428178



6x
6310449



1x
4211389



2x
6267495



6x
4211511



2x
4213567



6x
6383177



4x
6401023



4x
4211356



6x
4211445



16x
4211481



2x
4654582



2x
6469440



4x
6176433



12x
6335936



4x
4211098



1x
4211088



3x
4211060



1x
4211085



4x
4211044



4x
4558955



18x
4535930



22x
4211127



12x
4210848



4x
4210719



9x
4211063



14x
4211052



14x
6092572



16x
4210635



2x
6126083



2x
6309059



6x
6177079



10x
4211094



2x
4211055



31x
6247784



31x
6343852



4x
4568734



1x
4211133



12x
4211043



2x
4211053



19x
6039176



4x
6307616



19x
4560184



5x
42110651



1x
4243831



2x
4210998



1x
4211115



1x
4211134



2x
6296892



1x
4543086



9x
6284596



2x
4210633



4x
6221607



3x
4210872



3x
4210869



6x
4211042



2x
4211010



10x
6164073



2x
4527082



1x
6310596



9x
6396412



6x
6012451



20x
4211045



6x
4218188



2x
4210678



20x
4211114



3x
6222063



8x
6212080



8x
6016488



8x
6470140



24x
6446336



[LEGO.com/service](https://www.lego.com/service)



YOU COULD WIN



YOU COULD WIN

Your feedback will help shape the future development of this product series.

Visit:

DU KÖNNTEST GEWINNEN

Dein Feedback trägt zur Weiterentwicklung dieser Produktreihe bei.

Geh auf:

VOUS POURRIEZ GAGNER

Vos commentaires nous aideront à concevoir les futurs produits de cette gamme.

Visitez :

POTRESTI VINCERE TU

La tua opinione ci aiuterà a migliorare la creazione futura di questa linea di prodotti.

Visita:

PUEDES GANAR

Tu opinión contribuirá al futuro de esta serie de productos.

Visita:

轻松获奖

您的反馈将有助于我们在今后改进本产品系列。

请访问:

[LEGO.com/productfeedback](https://www.lego.com/productfeedback)

You also have the chance to win a LEGO® set.

Terms and conditions apply.*

Außerdem hast du die Chance, ein LEGO® Set zu gewinnen.

Es gelten die Teilnahmebedingungen.*

Vous pourriez également gagner un ensemble LEGO®.

Des conditions s'appliquent.*

Hai anche la possibilità di vincere un set LEGO®.

Termini e condizioni sono applicabili.*

También tienes la oportunidad de ganar un set LEGO®.

Aplican términos y condiciones.*

您还有机会赢取乐高®套装。

条款和条件适用。*

*[LEGO.com/productfeedback-terms](https://www.lego.com/productfeedback-terms)

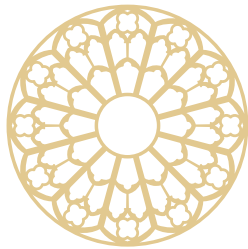

LEGO and the LEGO logo are trademarks of the LEGO Group. ©2024 The LEGO Group.
Adam Reed Tucker is the co-developer of the LEGO® Architecture product line.